

# **gorenje**

EN

## **Instructions for use**

### **Mixed gas & electric hob**

BGH6xxA - BGH6xxB - BGR6xxA  
BGR6xxB

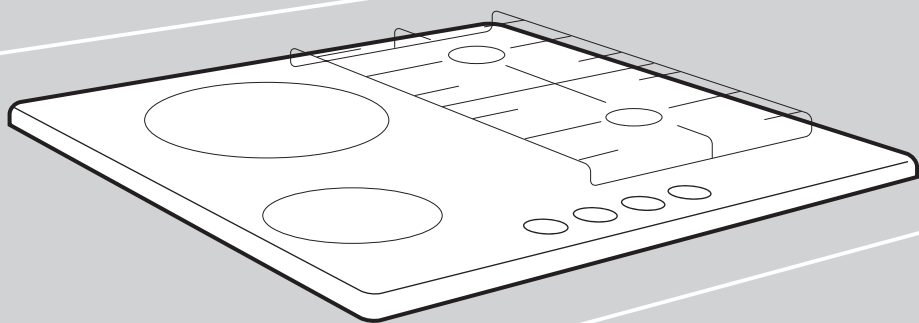

The following symbols are used throughout the manual, and they have the following meanings:

 **INFORMATION!**  
Information, advice, tip, or recommendation

 **WARNING!**  
Warning – general danger

 **GAS CONNECTION!**  
Warning – gas connection

 **ELECTRIC SHOCK!**  
Warning – danger of electric shock

 **HOT SURFACE!**  
Warning – danger of hot surface

 **DANGER OF FIRE!**  
Warning – danger of fire

✓ **RIGHT!**

✗ **WRONG!**



It is important that you carefully read the instructions.

# Contents

<b>Safety regulations</b> .....	<b>4</b>
READ CAREFULLY AND KEEP IT FOR FUTURE REFERENCE! .....	4
<b>Safe use</b> .....	<b>8</b>
<b>User Manual</b> .....	<b>9</b>
Models .....	9
Description .....	10
Information according to regulation (EU only) 66/2014 .....	11
Use .....	12
Burner position: .....	15
Cleaning: .....	15
On/Off- & Residual heat indicator .....	17
Faults table .....	18
<b>Installation instruction</b> .....	<b>19</b>
Safety regulations .....	19
Preparations for installation .....	20
Sealing tape .....	21
Gas connection .....	21
Accessibility .....	21
Built-in .....	21
Connecting & testing .....	22
<b>Conversion instruction</b> .....	<b>23</b>
Conversion table .....	23
Power table (kW-g/h): .....	23
Converting nozzles .....	24
Converting by-pass screws .....	24
Check for gas tightness and operation .....	25
Startup .....	25
Checking operation .....	25
<b>Environmental considerations</b> .....	<b>26</b>
Disposal of the appliance and packaging .....	26

# Safety regulations



## READ CAREFULLY AND KEEP IT FOR FUTURE REFERENCE!

### General

- The manufacturer cannot be held liable for any damage resulting from failure to follow the safety instructions and warnings.
- Damage caused by incorrect connection, incorrect fitting, or incorrect use is not covered by the warranty.

### **WARNING!**

This appliance and the accessible parts will become hot during use. Do not touch hot parts. Keep children younger than 8 away from the appliance unless they are under continuous supervision.

### **DANGER OF FIRE!**

**WARNING:** Danger of fire: do not store items on the cooking surfaces.

- **CAUTION!** The cooking process has to be supervised. A short-term cooking process has to be supervised continuously.

### **DANGER OF FIRE!**

**WARNING:** Cooking with fat or oil on a hob without supervision can be dangerous and can lead to a fire.

- NEVER try to extinguish a fire with water. Instead, switch the appliance off and then cover the flames with, for example, a lid or a fire blanket.

 **WARNING!**

Use only hob guards designed by the manufacturer of the cooking appliance or indicated by the appliance manufacturer in the instructions for use as suitable or hob guards incorporated in the appliance. The use of inappropriate guards can cause accidents.

- The hob is only to be used for the preparation of food.
- The appliance is not designed for heating rooms.
- Do not warm closed tins on the hob. There will be a build-up of pressure that will cause tins to explode. You might get injured or scalded.
- The appliance is not intended to be operated by means of an external timer or separate remote control system.
- Never open the casing of the appliance.
- Never use a pressure cleaner or steam cleaner to clean the hob.
- The ceramic top is extremely strong but not unbreakable. For example, a spice jar or sharp utensil falling on it could cause it to break.

- If a drawer underneath the appliance is permitted (see the installation instructions), without an intermediate bottom, this should not be used to store highly flammable objects/materials. Ensure that there is adequate clearance of a few centimetres between the bottom of the hob and the contents of any drawers.
- CAUTION! The use of a gas cooking appliance results in the production of heat, moisture and products of combustion in the room in which it is installed. Ensure that the kitchen is well ventilated especially when the appliance is in use. Keep natural ventilation holes open or install a mechanical ventilation device (mechanical extractor hood).
- The burner components are hot during and immediately after use. Do not touch them, and avoid contact with non-heat resistant materials.
- The distance between the pan and a knob or non-heat resistant wall should always be greater than one centimetre. In the case of smaller distances, the high temperature may cause the knobs or wall to discolour and/or deform.



### **ELECTRIC SHOCK!**

#### **WARNING! In case of hotplate glass breakage:**

- Shut immediately off all burners and any electrical heating element and isolate the appliance from the power supply.
- Do not touch the appliance surface.
- Do not use the appliance.

 **WARNING!**

- This appliance can be used by children aged 8 years and over, as well as by people with reduced physical, sensory or mental capabilities or lack of experience and knowledge, provided they are supervised and instructed in the safe use of the appliance and understand the hazards involved.
- Do not allow children to play with the appliance.
- Do not allow children to clean or maintain the appliance unless supervised.
- Do not keep objects that children might find interesting in cupboards above or behind the appliance.
- The cooking zones/burners heat up during use and stay hot for a while afterwards. Keep young children away from the hob during and immediately after cooking.

## Safe use

- Never cover the appliance with a cloth or something similar. If the appliance is still hot or is switched on, there is a risk of fire.
- Do not use the appliance as a worktop. The appliance may accidentally be switched on or still be hot, which means objects could melt, become hot or catch fire.
- Do not use the appliance in temperatures below 5 °C.
- The appliance should not be placed or used outdoors.
- Never flambé under a cooker hood. The high flames can cause a fire, even if the cooker hood is switched off.
- Always place the pan on the pan support. Placing the pan directly on the burner cap can result in dangerous situations.
- The hob can only function effectively if the burner components have been assembled using the guide ridges. Ensure that the pan supports lie properly against each other and flat on the drip tray. Only then can the pans be positioned stably.
- Do not use griddle plates or baking plates.
- Clean the burner parts regularly for the safe and correct operation of the burners.
- Missing rubber feet from the pan supports can cause scratches on the drip tray or poor combustion of the burner. If the rubber feet are missing, please contact our service department.
- Never immerse hot burner caps and pan supports in cold water. Rapid cooling can damage the enamel.
- After turning the electric heating elements off it will remain hot for a prolonged period of time. Avoid contact with the electric heating elements during this time.



# User Manual

## Models

Aa - Auxiliary burner

Bb - Semi-rapid burner

Cc - Rapid burner

Dd - ø 180 mm heating element

Ee - ø 145 mm heating element

**BGH6xxA**

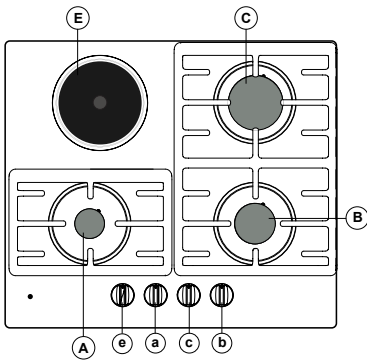

**BGH6xxB**

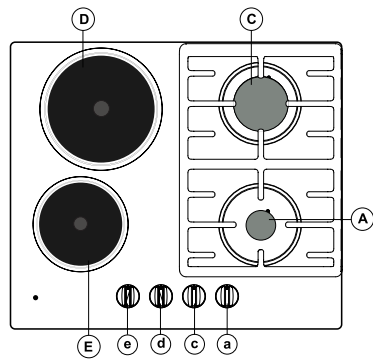

**BGR6xxA**

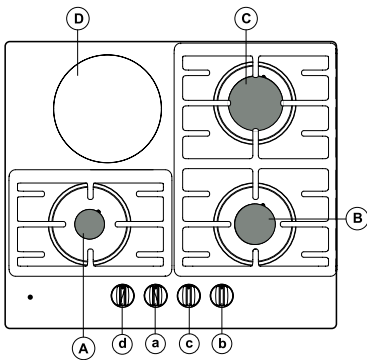

**BGR6xxB**

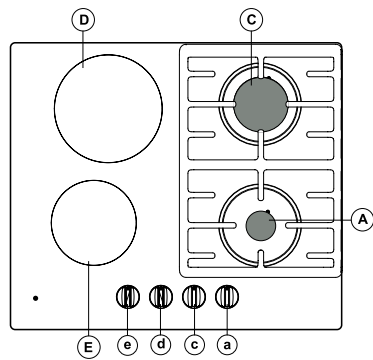

# Description

## Gas burner

	<b>G20 - 20 mbar</b>			
	Burner	Power	BGH6xxA BGR6xxA	BGH6xxB BGR6xxB
<b>Aa</b>	Auxiliary	1.05 kW	x	x
<b>Bb</b>	Semi-rapid	1.80 kW	x	
<b>Cc</b>	Rapid	3.00 kW	x	x

	<b>G20 - 25 mbar</b>			
	Burner	Power	BGH6xxA BGR6xxA	BGH6xxB BGR6xxB
<b>Aa</b>	Auxiliary	1.00 kW	x	x
<b>Bb</b>	Semi-rapid	1.90 kW	x	
<b>Cc</b>	Rapid	3.00 kW	x	x

	<b>G30/G31 - 28-30/37 mbar</b>			
	Burner	Power / Mass flow	BGH6xxA BGR6xxA	BGH6xxB BGR6xxB
<b>Aa</b>	Auxiliary	1.05 kW / 76 g/h	x	x
<b>Bb</b>	Semi-rapid	1.70 kW / 122 g/h	x	
<b>Cc</b>	Rapid	3.00 kW / 216 g/h	x	x

	<b>G30/31 - 50 mbar</b>			
	Burner	Power / Mass flow	BGH6xxA BGR6xxA	BGH6xxB BGR6xxB
<b>Aa</b>	Auxiliary	1.0 kW / 72 g/h	x	x
<b>Bb</b>	Semi-rapid	1.90 kW / 137 g/h	x	
<b>Cc</b>	Rapid	3.00 kW / 216 g/h	x	x

## Electric heating element

	<b>Nominal Power (Max. heat setting) [W]</b>				
	Heating element	BGH6xxA	BGH6xxB	BGR6xxA	BGR6xxB
<b>Dd</b>	ø 180 mm		2000	1800	1800
<b>Ee</b>	ø 145 mm	1500	1500		1200

# Information according to regulation (EU only) 66/2014

Measurements according to EN60350-2

Model identification		BGH6xxA	BGH6xxB	BGR6xxA	BGR6xxB
Type of hob		Mixed gas & electric hob			
Number of electric heating elements		1	2	1	2
Heating technology per electric heating elements		Solid plates		Radiant heating elements	
Diameter electric heating element	Large heating element:		Ø 180 mm		Ø 180 mm
	Small heating element:	Ø 145 mm	Ø 145 mm	Ø 180 mm	Ø 145 mm
Energy consumption per kg (EC <sub>electric cooking</sub> )	Large heating element:		193.6 Wh/kg	182.9 Wh/kg	189.7 Wh/kg
	Small heating element:	184.3 Wh/kg	190.4 Wh/kg		189.9 Wh/kg
Number of gas-fired burners		3	2	3	2
Energy efficiency per gas burner (EE <sub>gas burner</sub> ) in %	Semi-rapid burner:	58.1	-	58.1	-
	Rapid burner:	57.1	57.1	57.1	57.1

# Use

## Before first use

### BGH6xxA/B:

Turn on the electric heating elements (without a pan) for 3-5 minutes at maximum power. During this time, the protective coating forms a durable layer on the electric heating elements. There may appear some smoke the first time the elements are heating up.

### BGR6xxA/B:

Clean the heating elements with a damp cloth.

Turn on the electric heating elements (without a pan) for 3-5 minutes at maximum power.

## During use

### BGH6xxA/B

Stainless steel parts around the electric heating elements may discolour due to the thermal load during cooking.



#### WARNING!

After turning the electric heating elements off it will remain hot for a prolonged period of time. Avoid contact with the electric heating elements during this time.

### BGR6xxA/B:

The temperature of the heating elements is internally controlled by constantly switching the element on and off. When the heating element is turned on, a clear red glow is present.

When the heating element is set to a low heating setting, the element is switched off more frequently and for a longer period of time.



#### WARNING!

After turning the electric heating elements off it will remain hot for a prolonged period of time. This is indicated by the residual heat indicator. Avoid contact with the electric heating elements during this time.

## Cookware

### Gas burners

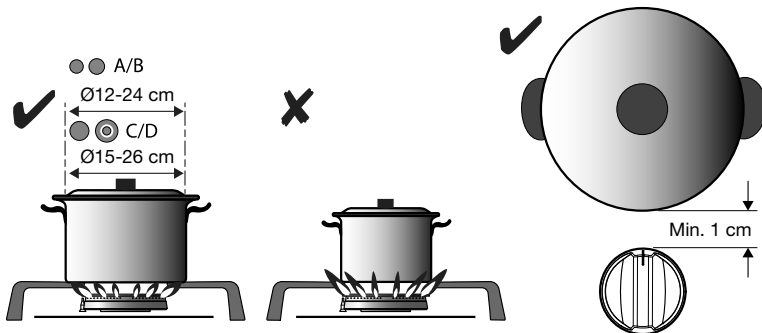

## Electric heating elements

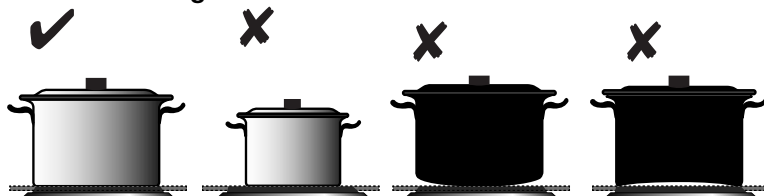

### **WARNING!**

BGH6xxA/B & BGR6xxA/B

- The distance between the pan and a non-heat resistant wall should always be greater than one centimetre. In the case of smaller distances, the high temperature may cause the knobs or wall to discolour and/or deform.
- Always keep the pans within the edges of the hob.
- The bottom surface of the pans and the electric heating elements should always be clean and dry to ensure good heat conduction and prevent damage to the cooking surface.
- When cooking in a pot made of refractory and heat-resistant glass or porcelain, follow the instructions of the manufacturer.
- Make sure the pan always has enough fluids in them. Empty pans may cause the hob to overheat, resulting in a damaged worktop or hob.

### **WARNING!**

BGR6xxA/B

- Do not use pans with a rough bottom as they may scratch the cooking surface. Sand (e.g., vegetables) may scratch the cooking surface.
- Do not move the dish on the cooking surface, this may result in scratches.
- The cooktop is solid but not resistant to pinpoint strikes. Make sure that no hard and/or sharp objects fall on it as it may damage the surface.
- Sugar and sweet foods can greatly damage the glass-ceramic surface. Remove them immediately with the scraper to avoid damage to the surface, even if the hob is still warm.
- Do not cook on the cooking surface in a thin-walled aluminium pan and foil, as well as plastic containers. These materials can melt and damage the hob.

**Control:**

BGH6xxA/B & BGR6xxA/B  
Control of gas burners

- (1) Push
- (2) Turn left + hold
- (3) Hold down 3 sec.

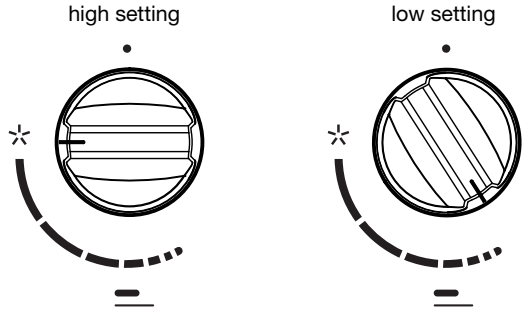
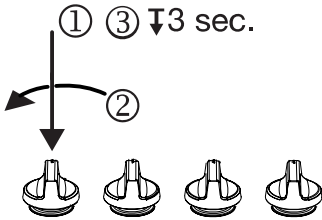

BGH6xxA/B

**BGH6xxA/B** Control of electric heating elements

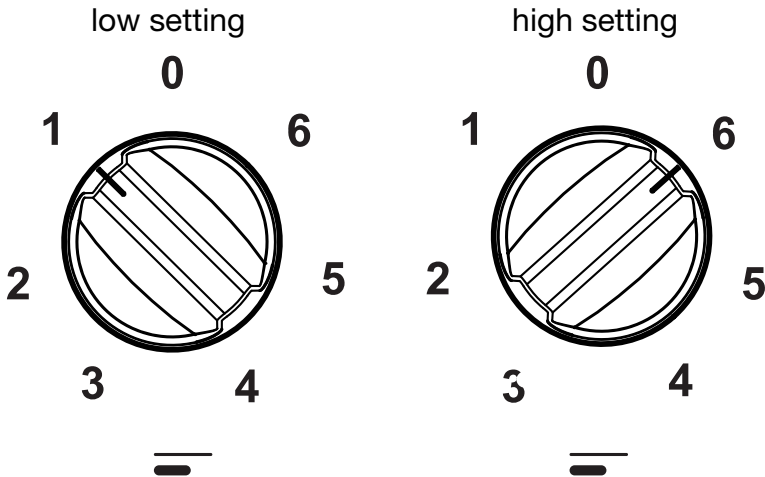

BGR6xxA/B

### BGR6xxA/B Control of electric heating elements

high setting

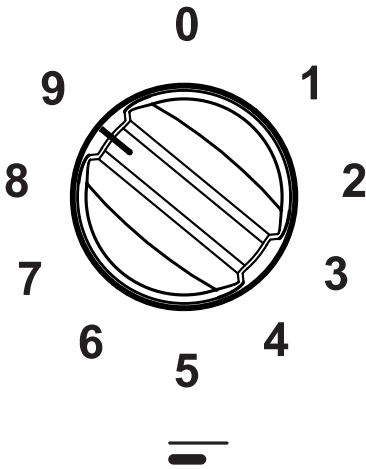

low setting

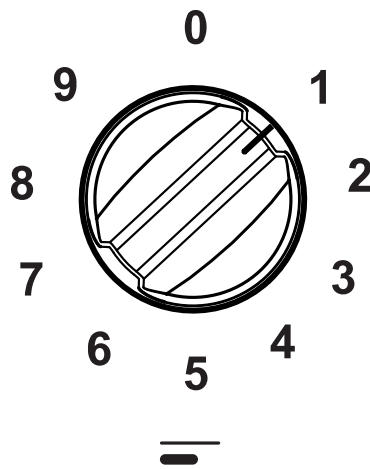

### Burner position:

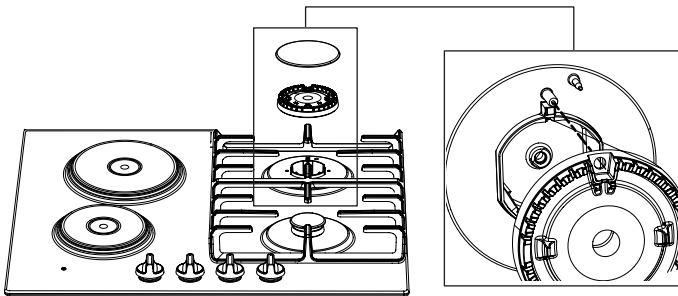

### Cleaning:

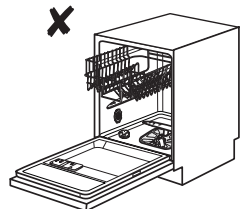
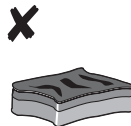

We recommend that you clean the appliance after each use. This prevents that overcooked food can damage the glass surface.

## **BGH6xxA/B**

### Daily cleaning

Use warm water with some dishwashing detergent to clean the area around the electric heating elements. Before doing so, use a sponge to soften any stubborn residues.

Heavy polluted electric heating elements

All dirty heating elements should be cleaned thoroughly immediately after use when the heating elements are cooled down. If the heating elements are less stained, it suffices to wipe them with a damp cloth soaked in water and some detergent. If the element is heavily soiled, use a steel sponge (wire scrubber) soaked with the detergent. After cleaning, the heating elements should always be wiped dry.

Salt-containing liquids dished that have boiled over, or moisture can damage the heating elements. Therefore, always wipe the heating elements clean and dry.

### Maintenance

To condition, the electric heating elements, occasionally use some sewing machine oil, or conventional products for cleaning and care, available in the market. Never use butter, bacon/lard, or a similar substance (risk of corrosion). If the heating element is slightly warm, the detergent will penetrate the pores more quickly.

## **BGR6xxA/B**

### Daily cleaning

Use a damp cloth and a mild cleaning agent (washing-up liquid) to clean the appliance.

Dry the appliance with a paper towel or a cloth.

### Heavily polluted glass

1. Immediately remove any food remains, burned grease, sugar or stubborn stains from the glass-ceramic hob using a scraper, even if the hob is still hot! Sugar and/or other food-related remains may permanently damage the glass-ceramic surface.

- Hold the scraper at the correct angle (45° to 60°) relative to the glass. Gently press the scraper against the glass and slide it over the surface to remove the dirt. Make sure the plastic handle of the scraper (in some models) does not come into contact with a hot heating element.
- Do not press the scraper perpendicularly against the glass.
- Do not scratch the hob surface with the tips of the scraper blade. This can cause permanent scratches in the glass.

2. After you have removed the stubborn stains from the glass, use the steps of the daily cleaning to clean the hob.

3. If the cleaning results are not to your satisfaction you can repeat the above cleaning steps as often as needed.



### **WARNING!**

Do not use abrasive cleaning agents, because they can cause scratches.

Do not use steel wool, scourers or any type of sharp object to clean the appliance.

The hob can still be very hot due to the cooking process! Do not touch the surface directly. If desired use gloves to prevent burning while cleaning directly after cooking.



# On/Off- & Residual heat indicator

## BGH6xxA/B:

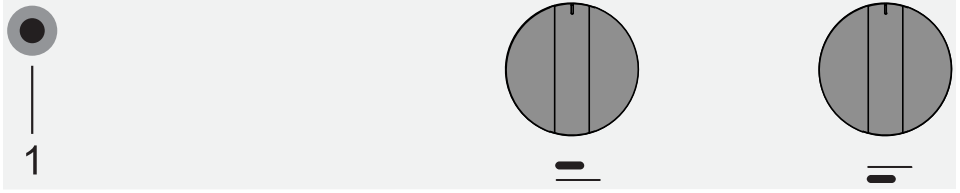

1. On/Off indicator:

Indicates whether one or multiple heating elements are turned on.

### **WARNING!**

If the heating element is turned off, the On/Off indicator will also turn off. However, the electric heating elements will remain hot for a prolonged period of time after turning off. Risk of injury when touching the hot heating element during this time.

## BGR6xxA/B:

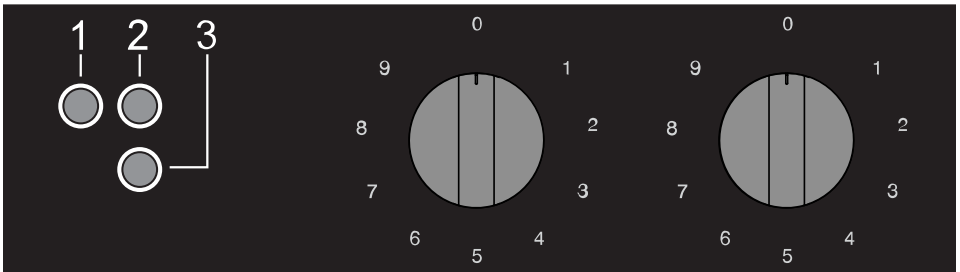

1. On/Off indicator: Indicates that one or multiple heating elements turned on.
2. Residual heat indicator rear heating element: Indicates that the rear heating element is (still) hot.
3. Residual heat indicator front heating element: Indicates that the front heating element is (still) hot.

### **HOT SURFACE!**

Warning! Risk of injury when touching the hot heating element.

# Faults table

Following is some advice on rectifying some common problems.

What happened...?	Possible cause	What to do?
The burners will not burn. The flame is uneven/unstable.	The flame is uneven due to a wrong gas power setting.	Have an expert check the gas pipeline!
The flame from the burners suddenly changes.	Wrongly assembled parts of the kitchen hob.	Assemble the burner correctly.
Burner ignition takes more time.	Wrongly assembled parts of the kitchen hob.	Assemble the burner correctly.
The flame is extinguished shortly after ignition.	Knob pressed too short or too weakly.	Keep the knob pressed for a longer period of time.
The grid has discoloured in the burner area?	This is a commonplace phenomenon resulting from high temperatures.	Clean the grid with a metal care detergent.
Electric power supply, in general, is interrupted?	The fuse may be blown.	Check the fuse in the fuse box and replace it if it is blown.
Electric ignition of the burners no longer works?	There are food or detergent residues between the spark plug and the burner.	Open and carefully clean the opening between the spark plug and the burner.
The burner cover looks unappealing.	Regular dirt.	Clean the burner covers with a metal care detergent.
A slight smell is noticeable the first time electric heating elements are used.	The new appliance is heating up.	This is normal and will disappear once it has been used a few times. Ventilate the kitchen.

## NOTE!

A visit by a service technician during the warranty period will be charged if the appliance is not functioning because of improper use. Store these instructions in a place where they are always readily accessible; if you pass the appliance on to another person, the instructions should also be included.

If the problem persists despite observing the instructions above, call an authorized service technician. Elimination of any errors or warranty claims that resulted from an improper connection or use of the appliance is not covered by our warranty. In such cases, the costs of repair are borne by the user.

# Installation instruction

## Safety regulations



- Faulty parts may only be replaced by original parts.

The manufacturer can only guarantee that original parts meet safety requirements.

- If the supply cord is damaged, it must be replaced by the manufacturer, its service agent or similarly qualified persons in order to avoid a hazard.
- This appliance should only be connected by a registered installer.
- Prior to installation, ensure that the local distribution conditions (voltage, frequency, nature of the gas and gas pressure) and the adjustment of the appliance are compatible.

### **Electrical connection Class I - 220-240 V - 50/60 Hz - max 3500 W.**

- This appliance must be earthed.
- The voltage, frequency, power, type of gas and the country for which the appliance has been designed are shown on the appliance rating plate.
- The electrical connection must comply with national and local regulations.
- If a stationary appliance is not fitted with a supply cord and a plug, or with other means for disconnection from the supply mains having a contact separation in all poles that provide full disconnection under overvoltage category III conditions, the means for disconnection must be incorporated in the fixed wiring in accordance with the wiring rules. Using an omnipolar switch with a contact separation of at least 3 mm fitted in the supply cable will fulfil this requirement.

### **Gas connection 1/2" ISO 228 / ISO 7-1 / EN 10226-1 (1/2" ISO 228 / 1/2" ISO 228 FR only).**

- The gas connection must comply with national and local regulations. See appliance label for technical gas data.
- This appliance is not connected to a combustion products evacuation device. It shall be installed and connected in accordance with current installation regulations. Particular attention shall be given to the relevant requirements regarding ventilation.
- We recommend that the gas hob be connected by means of a fixed pipe. Connection using a specially designed safety hose is also permitted.
- The pipe behind the oven must be made entirely out of metal.

- A safety hose may not be bent and must not come into contact with moving parts of kitchen units.
- The gas supply valve must always be placed in an easily accessible position.
- The walls and the worktop surrounding the appliance must be heat resistant up to at least 105 °C.
- The bottom kitchen element must be equipped with a built-in horizontal shelf at a distance of not less than 15 cm from the bottom surface of the worktop. The space between the shelf and the cooktop must be empty and may not be used for the storage of utensils.

## Preparations for installation

### Free space around the appliance

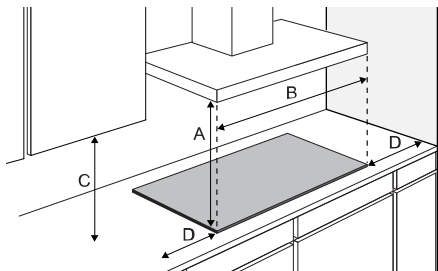

A (mm)	B (mm)	C (mm)	D (mm)
min. 650	min. 600	min. 450	min. 120

### Dimensions

#### Appliance:

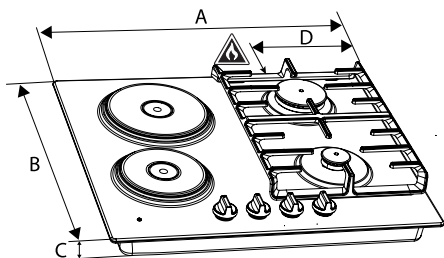

A (mm)	B (mm)	C (mm)	D (mm)
600	520*	52	138
600	522**	52	138

\*BGH6xxA/B

\*\*BGR6xxA/B

#### Built-in:



#### WARNING!

The bottom kitchen element must be equipped with a built-in horizontal shelf at a distance of not less than 150 mm from the bottom surface of the worktop. The space between the shelf and the cooktop must be empty and may not be used for the storage of utensils.

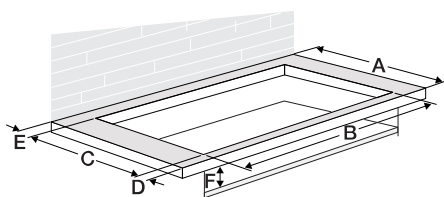

A (mm)	B (mm)	C (mm)	D (mm)	E (≥mm)	F (mm)
600	560	490	60	50	150

## Sealing tape

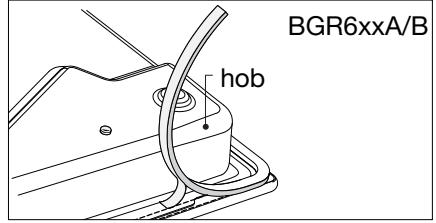
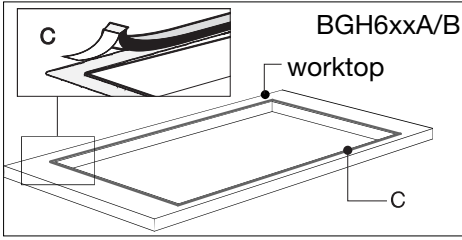

## Gas connection

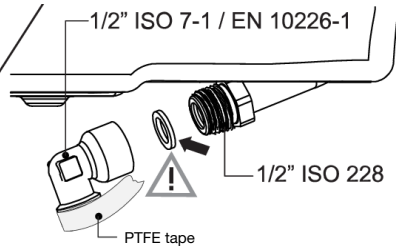
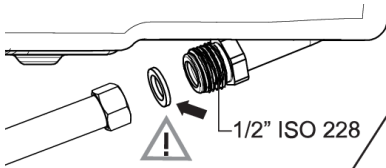

## Accessibility

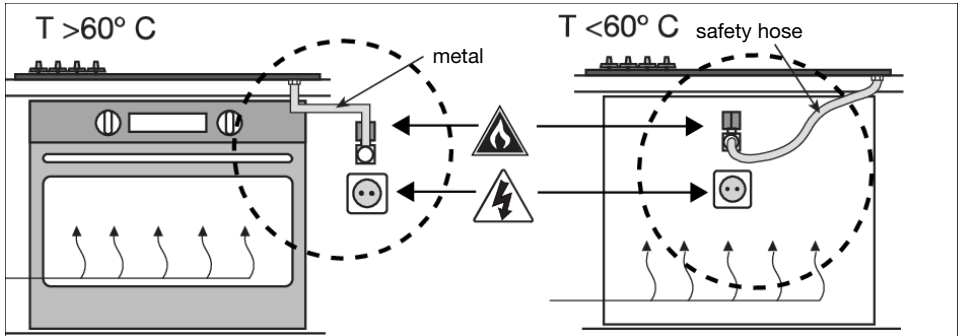

## Built-in

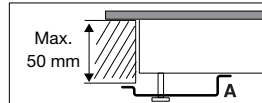
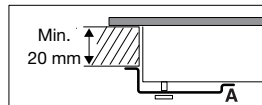
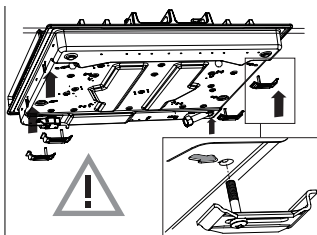
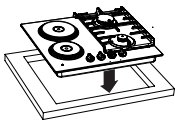

## Connecting & testing

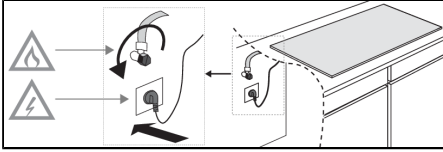

### **WARNING!**

Check if connections are gas-tight.

# Conversion instruction



## WARNING!

Adjusting for a different gas type!



## WARNING!

**Attention!** Performing these instructions by a non-qualified person can lead to dangerous situations. The supplier is not responsible for the consequences (the arising of a hazardous situation and/or damage to persons or goods) caused by the incorrect performance of these instructions by engineers who are not employees of the supplier. Consequential damage arising through the inexpert performance of these instructions is not accepted.

With this conversion set, your gas hob can be converted to different gasses. See the conversion table.

## Conversion table

Gas type	P mbar	Modification	Auxiliary	Semi rapid	Rapid
			nozzle	nozzle	nozzle
G20	20	-	72	97	128
G20	25	-	68	95	110
Convert from G20 - 20 mbar or from G20 - 25 mbar to:					
G30/G31	28-30/37	Replace nozzle & screw in bypass (see 3A)	50	65	85
(PL) G30/G31	37	Replace nozzle & screw in bypass (see 3A)	50	65	85
G30/G31	50	Replace nozzle & screw in bypass (see 3A)	43	60	75

Gas type	P mbar	Modification	Auxiliary	Semi rapid	Rapid
			nozzle	nozzle	nozzle
G30/G31	28-30/37	-	50	65	85
Convert from G30/G31 - 28-30/37 mbar to:					
G20	20	Replace nozzle & adjust bypass (see 3C)	72	97	128
G20	25	Replace nozzle & adjust bypass (see 3C)	68	95	110

## Power table (kW-g/h):

	PL G30/G31 - 37 mbar
<b>Auxiliary burner</b>	1.15 / 83
<b>Semi-rapid burner</b>	1.95 / 140
<b>Rapid burner</b>	3.30 / 238

## Contents of conversion set

- Nozzles for burners and (if applicable) by-pass screws for gas taps.
- Data label with the modified gas specifications and setting.

### Tools needed:

- T1 Socket spanner (7 mm)
- T2 Screwdriver flat blade (4 mm)
- T3 Nose pliers
- T4 Open-end spanner (7 mm)
- T5 Leak test spray

## Converting nozzles



### NOTE!

**Please note: disconnect the appliance from the power supply.**

Prevent damage of the worktop. Lay down parts of the appliance on a protected base.

For converting to a different type of gas, the nozzles have to be changed.

The values are also marked on the nozzle.

1. Remove pan supports, burner heads, crowns and covers (see pictures A1 and A2). Pull off the control knobs vertically.
2. Use the socket (T1) or open-end spanner (T4) to remove the old nozzles and place the new nozzles inside the burner cups (see pictures A1 and A2).

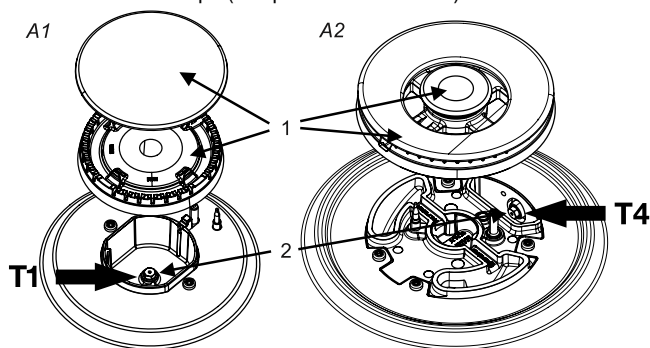

## Converting by-pass screws

Depending on the gas type to which the appliances will be converted, there are two ways to adjust the by-pass screws.

Please check the conversion table in the column “Modification” if the by-pass screws have to be screwed completely in (see action 3A), replaced by a different by-pass screw (see action 3B) or adjusted (see action 3C).

The values are also indicated on the top of the by-pass screws. The by-pass screws can be reached from the top of the hob when the knobs are removed (B2).



3A. Screw the by-pass screws (3) of all gas taps completely in by using the flat-blade screwdriver (T2).

3B. Remove the by-pass screws by using the flat-blade screwdriver (T2) and the nose pliers (T3). Place the new by-pass screws with the nose pliers and screw the by-pass screws of all gas taps in, by using the flat-blade screwdriver.

3C. Adjust the by-pass screws (3) of all gas taps by using the flat-blade screwdriver (T2) until a stable flame is established with a minimal gas flow. Please check if the flame is stable in the cold and hot conditions of the burner.

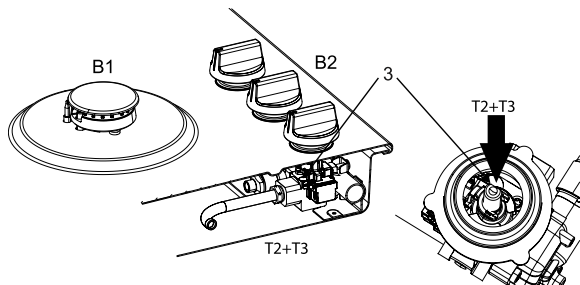

## Check for gas tightness and operation

When the appliance is connected to the gas supply, use leak test spray to check the gas tightness.

1. Seal the injector.
2. Open the gas tap. **Attention:** press and open the tap to override the thermo-electric safety device and keep it pressed down.
3. Spray leak test spray over all gas connections and check for gas tightness.
4. Repeat for every burner.

## Startup

1. Reinstall the knobs, burner parts and pan supports.
2. Check if the appliance is connected to the correct gas type and pressure.
3. Open the main gas valve.
4. Insert the plug into the power socket.

## Checking operation



ADJUSTED FOR	SKORYGOWANIE O	CL
EINGESTELLT AUF	KORRIGALT	
3 TROPÄNDÖD HA	HACTIPGHO JDR	
PRILAGDEN ZA	KETECY VUIHI TEHUEZTEH	
PO OČSTENI O		
PRILAGDEN ZA		
AJUSTATE PENTRU	GXX XX mbar	

1. Ignite the burners.
2. Check whether the flame profile is normal, uniform and stable for the complete ratio:
3. Check if the flame does not smother in simmer rate;
  - Check if the flames are not 'blowing off' at maximum rate;
  - No long, yellow flames should be visible during operation.
4. Paste the data label with the modified gas specifications and setting over the current data label with the old specification (at the underside of the appliances nearby the gas connection).

# Environmental considerations

## Disposal of the appliance and packaging

Sustainable materials have been used during the manufacture of this appliance.

The appliance packaging is recyclable. The following may have been used:

- cardboard;
- paper;
- polyethylene film (PE);
- CFC-free polystyrene (PS-rigid foam);
- polypropylene tape (PP).

Dispose of these materials in a responsible manner and in accordance with government regulations.



To designate the requirement for a separate collection of household electrical appliances, the symbol of a crossed-out dustbin is applied to the product.

This means that at the end of its working life, the product must not be disposed of as urban waste. It must be taken to a special local authority differentiated waste collection centre or to a dealer providing this service. Disposing of a household appliance such as this hob separately avoids possible negative consequences for the environment and health and enables the constituent materials to be recovered, resulting in significant savings in energy and resources.



### NOTE!

**Please note! Do not throw a broken ceramic glass plate in the glass recycling bin but take this to the Municipality's waste recycling centre.**

## Declaration of conformity



We hereby declare that our products satisfy the applicable European directives, orders and regulations, as well as the requirements stated in the referenced standards.



# **gorenje**

[www.gorenje.com](http://www.gorenje.com)



857146-a8

CE