

**Thank you for your trust and for buying this appliance. We hope it will successfully serve the purpose for many years.**

The upright freezer for domestic use is intended for freezing fresh food and for long-term storing of frozen food (up to one year), depending on the kind of food.

<b>Before Putting Into Use</b> .....	12	Switching on the appliance	
Instructions for Use		Switching off the appliance	
We Care for the Environment		Selecting the temperature in the appliance	
A few tips on how to save power with your refrigerator-freezer combo		<b>Freezing and storing frozen food</b> .....	16
<b>Important</b> .....	13	Freezing process	
Storing Time During Power Supply Interruption		Important warnings on freezing fresh food	
Disposing of the Worn Out Appliance		Storing Frozen Foods	16
<b>Placing and Installation</b> .....	14	Defrosting of Frozen Food	
Choosing the Right Place		<b>Changing the Direction of Opening the Door</b> 17	
Location		<b>Maintenance and Cleaning</b> .....	18
Connection to Power Supply		Freezer Defrosting	
<b>Description of the Appliance</b> .....	15	Cleaning the Appliance	
<b>Operating the appliance</b> .....	15	Switch Off the Appliance When Not in Use	
		<b>Trouble Shooting Guide</b> .....	20

## **i** Before Putting Into Use

- Before connecting the appliance to the mains supply, leave it for about 2 hours to stand in place where it will later on be installed. This will reduce the possibility of malfunctions in the cooling system that might have occurred due to transport handling.
- Clean the appliance thoroughly, especially the interior (see Cleaning and Maintenance).
- When your appliance finally wears out, please try not to burden the environment with it; call your nearest authorised service agent. (See Disposing of the Worn Out Appliance).

### **A few tips on how to save power with your refrigerator-freezer combo**

- Observe the installation instructions.
- Do not open the appliance door more frequently than necessary.
- Occasionally check whether air can circulate freely behind the appliance.
- Condenser unit mounted on the appliance back wall must be kept clean at all times (see section "Cleaning the appliance").
- If the seal is damaged or loose, replace it as soon as possible.
- Store your food in closed containers or other appropriate packaging.
- Before placing the food in the refrigerator, let it cool down to room temperature.
- Defrost your frozen food in the refrigerator compartment.
- Remove the freezer drawers and door as described in the instructions, in order to make use of the entire capacity.

### **Instructions for Use**

These instructions for use were prepared for the user. They describe the appliance and its correct and safe use. They were prepared for various types/models of appliances therefore you might find in it some functions that do not apply to your appliance.

### **We Care for the Environment**

- Our products use environmentally friendly packaging, which can be either recycled or disposed of in an environmentally friendly manner. To this end, individual packaging materials are clearly marked.
- These instructions are printed either on recycled paper or chlorine free bleached paper.

- Defrost your conventional freezer when a frost layer approximately 3-5 millimetres thick has accumulated on the surfaces in the freezer compartment.
- Make sure the shelves are evenly distributed and that the food is arranged in a way that allows free circulation of air (heed the recommended food arrangement as described in the instructions).
- In appliances fitted with a fan, do not block the fan slots.

---

## Important

---

- This appliance is manufactured in compliance with relevant safety standards. However, it is still advisable it is not used without due supervision by persons with diminished physical, motoric, or mental capabilities or persons with inadequate experience or knowledge. The same recommendation applies to minors using the appliance.
- If you've bought this appliance to replace an old one equipped with a lock that cannot be opened from inside (lock, bolt), make sure that the lock is broken. This will make it impossible for the children to lock themselves in the appliance and suffocate.
- Mind to connect the appliance correctly to the mains supply (see Connection to the Mains Supply).
- Do not touch the cooled surfaces while the appliance operates, especially not with wet hands, because the skin might stick to the cold surfaces.
- Do not freeze bottled drinks, especially not fizzy ones such as mineral water, sparkling wine, beer, cola etc., because liquid expands during freezing and the glass bottle is very likely to blow up.
- Avoid eating frozen food (bread, fruit, vegetables), because you may get frostbites.
- Carefully check the foods for color and smell and if you are in doubt about their quality, throw them away because they may be spoiled and therefore dangerous to eat.
- Disconnect the appliance from the mains before repairing (only a qualified technician should repair it) and before cleaning.
- Use only enclosed tools or tools recommended by the manufacturer.
- For the sake of environment protection - be careful not to damage the rear wall of the appliance (the condenser unit or the tubes - for example when moving the appliance) or any part of the refrigerating system inside the appliance. Do not use sharp object for defrosting the appliance. Use only enclosed tools or tools recommended by the manufacturer.
- The refrigerating system of the appliance is filled with refrigerant and oil, so when the appliance is damaged, handle it with care and dispose it of in compliance with environmental protecting precautions. (See We Care for the Environment).
- Heating element incorporated in the appliance, all around the rim, is controlled by the operation of the compressor and it prevents the door gasket to freeze on to the freezer housing.
- The rating plate is in the interior wall or on the back of the appliance.
- **Warning!** Ventilation slots on the appliance or a built-in element must always be clean and unobstructed.
- **Warning!** Do not use mechanical devices or tools to defrost the refrigerator, nor any other methods except for those recommended by the manufacturer.
- **Warning!** When installing, cleaning, or removing the appliance, make sure the insulation on the refrigeration system parts is not damaged. Thus you will also prevent damage to the environment.
- **Warning!** Do not use electric appliances in the refrigerator or freezer interior, except for those expressly allowed by the refrigerator-freezer manufacturer.



**The symbol on the product or on its packaging indicates that this product may not be treated as household waste. Instead it shall be handed over to the applicable collection point for the recycling of electrical and electronic equipment. By ensuring this product is disposed of correctly, you will help prevent potential negative consequences for the environment and human health, which could otherwise be caused by inappropriate waste handling of this product. For more detailed information about recycling of this product, please contact your local city office, your household waste disposal service or the shop where you purchased the product.**

## Storing Time During Power Supply Interruption

Avoid opening the freezer in case of failure or power supply interruption! In case the interruption is extended over longer period of time (17 hours), take food out of the freezer and use it, or make sure that it remains frozen (if you have and additional appliance).

## Disposing of the Worn Out Appliance

- When your appliance finally wears out, dispose it of. If the appliance has a lock, break it, in order to prevent eventual accidents (danger of children get locked inside the appliance).

# Placing and Installation

## Choosing the Right Place

Place the appliance in dry and regular ventilated room. Allowed ambient temperature depends on the model (class) of the appliance and is stated on the rating plate of the appliance.

Never place the appliance near heat emitting devices (e.g. cooker, radiator, water heater and similar devices) and do not expose it to direct sunlight.

The appliance should be positioned at least 3 cm away from the electric or gas cooker and at least 30 cm away from the oil or coal stove. If this is not possible, use an appropriate insulation.

Behind the appliance there should be free space at least 200 cm<sup>2</sup> wide and above the appliance the high kitchen units should be at least 5 cm away from the appliance in order to assure adequate ventilation of the condenser unit.

Class	Ambient temperature
SN (sub-normal)	from + 10°C to + 32°C
N (normal)	from + 16°C to + 32°C
ST (sub-tropical)	from + 16°C to + 38°C
T (tropical)	from + 16°C to + 43°C

## Location

- Place the appliance horizontally and firmly on a solid base. Level the appliance with two adjustable feet located on the front of the appliance.

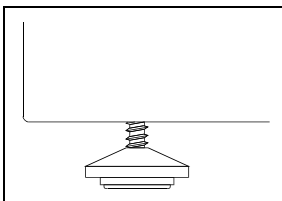

- The refrigerating system of the appliance is filled with refrigerant and insulating substances which should be separately treated and processed. Call your nearest authorised service agent or specialised servicing centre. If you don't find one, contact your local authorities or your distributor. Be careful not to damage the tubes on the rear wall of the appliance (danger of pollution).

- The appliance is supplied with air circulation grid. Built it in the working top exactly above the appliance.

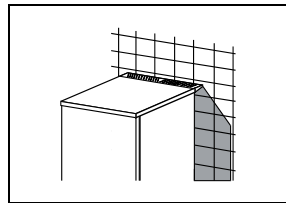

## Connection to Power Supply

Connect the appliance with the cable and plug to the power supply socket outlet with a ground terminal (safety socket).

Required nominal voltage and frequency are indicated in the rating plate.

The connection to the mains supply and earthing have to be made according to current standards and regulations.

The appliance resists temporary voltage tolerance up to -6 to +6 %.

# Description of the Appliance

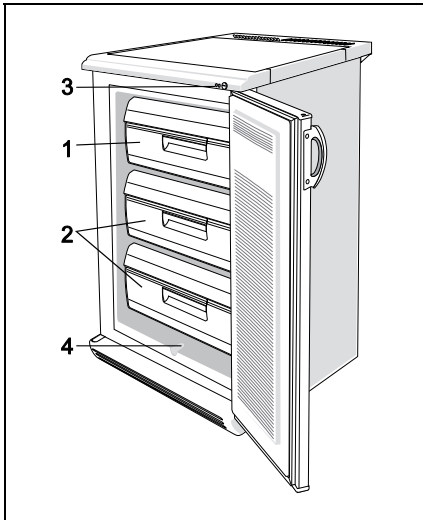

**Freezing Compartment (1)**  
is used for freezing fresh foods.

**Storing Basket (2)**  
is used for storing packages of frozen foods.

**Control Panel (3)**  
See Operating the appliance

**Defrost Water Outlet (4)**  
(See Cleaning and Maintenance).

**NOTE :**

- The appliance can be equipped with various accessories, depending on the model of the appliance.
- Door handles have various shapes, depending on the model.

# Operating the appliance

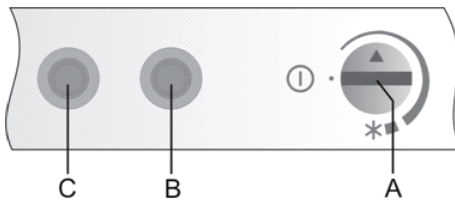

- A Temperature settings knob** – Switching the appliance on/off – Activating the super freeze function
- B Yellow signal light on:** Super freeze function is activated
- C Red signal light flashing:** High temperature alarm

## Switching on the appliance

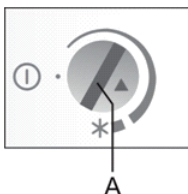

Rotate the thermostat knob **A** clockwise **towards the thicker end of the sign.**

When the appliance is switched on for the first time, there is a 24-hour delay in temperature alarm operation since the appliance will not have reached the adequate temperature. Thus, unnecessary activation of alarm is prevented.

## Switching off the appliance

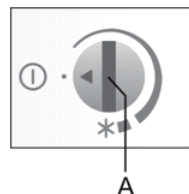

Rotate the **A** knob back to the position in which the arrow is aligned with the symbol  (appliance will remain powered, i.e. there will still be electric current in the appliance).

## Selecting the temperature in the appliance

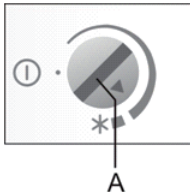

Recommended setting for the thermostat knob **A** is half way between the **thinner and the thicker** end of the sign.

A change in the environment temperature will affect the temperature in the appliance. The thermostat knob setting should be adjusted accordingly.

Positions towards the thicker part of the sign mean a lower temperature in the appliance

(cooler). Settings towards the thinner part of the marking mean a higher temperature (warmer).

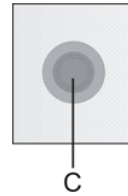

Signal light **C** will flash when the temperature in the freezer rises to a level that is too high, and goes off when the temperature drops back to a level that no longer represents food spoilage hazard (see section »Troubleshooting«).

# Freezing and storing frozen food

## Freezing process

**Maximum quantity of fresh food that can be introduced into the appliance at a time is indicated on the label with basic information on the appliance. If this quantity is exceeded, freezing quality will deteriorate, as will the quality of the already frozen food.**

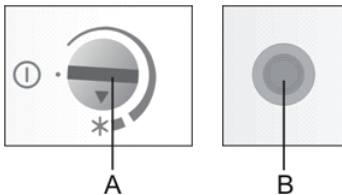

- Activate the super freeze function 24 hours before freezing fresh food:
  - rotate the **A** button to the \* (signal light **B** will light up).

After 24 hours, place the fresh food in the freezing compartment. Make sure the fresh food is not in contact with the food that is already frozen.

- When freezing smaller quantities of food (1-2 kilograms), activating the super freeze function is not required.
- After 24 hours, the food can be moved to other parts of the freezer and the freezing process can be repeated as required:

- rotate the **A** button back to the middle position and then after 5 seconds to the position \* (signal light **B** will light up).
- After the end of the freezing process, rotate the **A** dial back to the desired setting, even if the **B** signal light is not on (this means that sufficiently low temperature has already been reached).
- If the freezer boost is not deactivated manually, it will be automatically switched off after approximately 2 days. Then the temperature of the freezer compartment returns to the most recently set value (knob position remains at \*).

## Important warnings on freezing fresh food

- **The freezer should only be used for freezing food that is appropriate for freezing. The food should always be fresh and of adequate quality.**
- **Choose an appropriate packaging for the food and package it correctly.**
- **The packaging should be airtight and watertight to prevent loss of humidity or vitamins from the food.**
- **Indicate the type of food, quantity, and freezing date on each food package.**
- **It is important that the food is frozen as quickly as possible; therefore, smaller packages should be preferred. Before freezing, the food should be cooled.**

## Storing Frozen Foods

Packages of frozen foods are stored in the basket. If you remove the baskets, you can store frozen packages directly on the cooling shelves.

### Storing Commercially Frozen Foods

The storage time of commercially frozen foods is indicated on the packaging. For storing and use consider manufacturer's instruction. When shopping, be careful to choose only foods which are adequately packed and provided with complete data and stored in freezers where the temperature is not higher than -18°C.

Do not buy packages of food wrapped with frost. This indicates that the package was thawed before at least once. Packages of frozen foods should be carried well wrapped covered and as soon as possible stored in the freezer. A temperature rise shortens the storage time of commercially frozen foods.

### Approximate Storage Time for Frozen Foods

Food	Storage time (in months)											
	1	2	3	4	5	6	7	8	9	10	11	12
Vegetable								+	+	+		
Fruit										+	+	+
Bread, pastries			+									
Milk			+									
Ready-made meals			+									
Meat: Beef										+	+	+
Veal								+	+	+		
Pork				+	+	+						
Poultry								+	+	+		
Game							+	+	+			
Minced meat				+								
Smoked sausages	+											
Fish: lean			+									
fat	+											
Offal		+										

### Defrosting of Frozen Food

Partially thawed or defrosted foods should be used as soon as possible. Cold air preserves the food but it does not destroy microorganisms

which rapidly activate themselves after defrosting and make foods perishable.

Partial defrosting reduces the nutritional value of foods, especially of fruits, vegetables and ready-made meals.

## Changing the Direction of Opening the Door

If you find the direction of opening the door on your appliance inconvenient, you can change it. Holes on the opposite side have already been prepared in the factory.

- Unscrew the kick-plate and remove it by pushing downwards.
- Unscrew the lower hinge and take off the door together with the upper hinge washer.
- Unscrew the upper hinge fastener and fix it on the opposite side of the appliance.
- Take off, change and replace the door hinge fixture and the fixture plugs.
- Put the door with the upper hinge washer on the upper hinge fastener.
- Fix the lower hinge with washer on the new position.
- Replace the cover plate of the lower hinge to the opposite side of the kick-plate and fix it to the appliance.

- In case your appliance is equipped with a handle mounted on the side of the appliance, take it off and replace it on the other side. Some screws are covered with caps. Take them off before undoing the screws.
- Check the gasket, it shouldn't be creased and it should seal well.
- In the case that the door is not levelled an additional adjustment of the upper hinge support is necessary. The service intervention must be made by an authorised serviceman. Should the seal not adhere to the casing of the appliance perfectly, it will have to be heated from a suitable distance (by means of hair drier, for example) and lightly stretched to the required height.

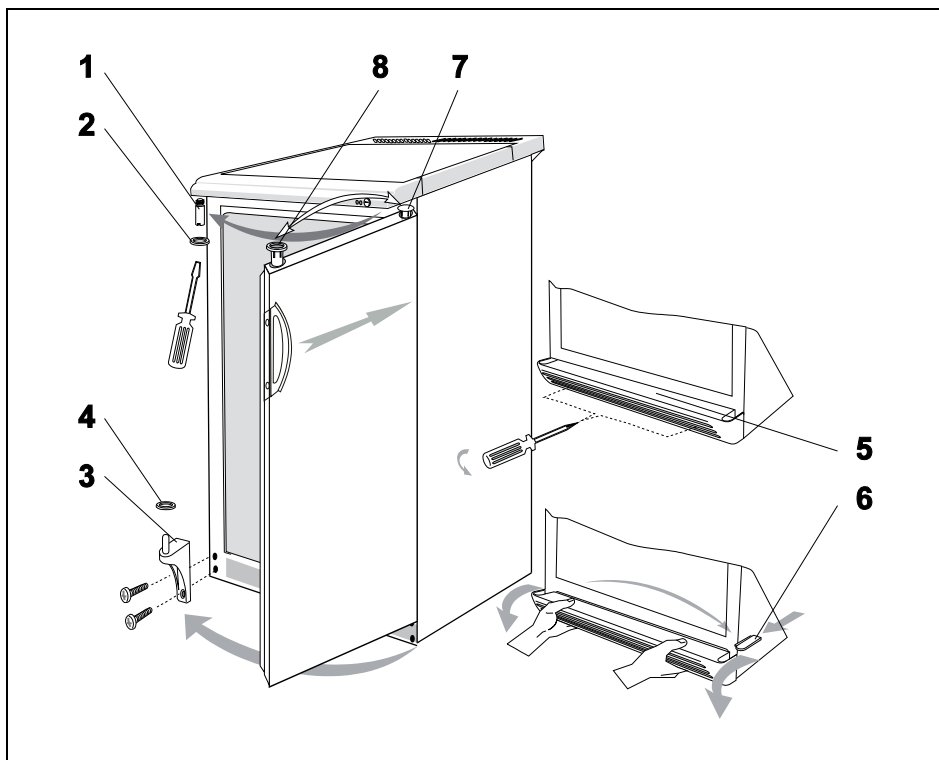

- 1 Upper hinge fastener
- 2 Upper hinge washer
- 3 Lower hinge
- 4 Lower hinge washer

- 5 Kick plate or control panel
- 6 Cover plate of the lower hinge
- 7 Fixture plug of the door hinge
- 8 Door hinge fixture

## Maintenance and Cleaning

### Freezer Defrosting

When the frost layer in the freezer is 3-5 mm thick, you should clean the freezer.

- 24 hours before defrosting, activate the freezer power boost to additionally cool the food (see chapter "Freezing process").
- After 24 hours, remove the frozen food from the freezer and protect them from thawing.
- Disconnect the appliance – rotate the thermostat knob **A** to the  position and unplug the power cord from the wall outlet.
- Insert the enclosed pipe into the groove in the bottom of the appliance and place a vessel underneath to collect the defrost water. Defrosting is accelerated if the door is left open.

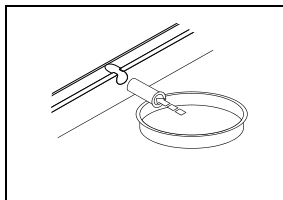

### Cleaning the Appliance

**Before cleaning the appliance disconnect the cable from the mains supply.** Do not use sharp tools or abrasive cleaning agents.

- Clean the **outside** surfaces of the appliances with water and detergent.
- Varnished surfaces are cleaned with soft cloth and an alcohol based cleaning agent (for

example glass cleaners). You may also use alcohol (ethanol or isopropyl alcohol). The application of abrasive and specially aggressive cleaners, such as the stainless steel cleaners, is not appropriate for the cleaning of plastic and coated parts.

- Wash the **inside** surfaces with lukewarm water and some vinegar.
- From time to time wipe **the condenser** on the rear wall with a soft non-metal brush or vacuum cleaner.

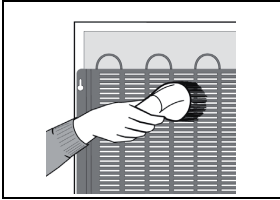

After you have cleaned the appliance, reconnect it to the mains supply and put the food packages back to their place.

### Switch Off the Appliance When Not in Use

If you do not intend to use the appliance for a longer period of time, disconnect the power supply, empty the freezer, defrost it and clean it. Leave the door slightly open.



# ? Trouble Shooting Guide

Problem:	Cause or remedy
After connecting to the power mains, the appliance does not operate:	<ul style="list-style-type: none"> <li>• Make sure the wall outlet is powered and that the appliance is plugged in.</li> </ul>
Cooling system has been working continuously for a long period of time:	<ul style="list-style-type: none"> <li>• Too high environment temperature.</li> <li>• Door is open too often or it is left open too long.</li> <li>• Door is not closed appropriately (there may be dirt between the door and the refrigerator, the door may be tilted, the seal should be checked, etc.).</li> <li>• Too much fresh food was inserted.</li> <li>• Insufficient compressor and condenser cooling. Check the air circulation behind the appliance and clean the condenser.</li> </ul>
Ice accumulation in the freezer interior is a result of:	<ul style="list-style-type: none"> <li>• Poor door sealing. If the seal is dirty or damaged, clean or replace it.</li> <li>• Door is opened too often or left open too long.</li> <li>• Placing warm food into the freezer.</li> </ul>
Signal light <b>C</b> is flashing:	<ul style="list-style-type: none"> <li>• Frequent opening of the door, door open too long.</li> <li>• Door not closed properly (particle between door gasket, sagged door, damaged gasket, etc...).</li> <li>• Excessively long power failure.</li> <li>• Excessive quantity of fresh food inserted at once.</li> </ul>
Door won't open easily:	<ul style="list-style-type: none"> <li>• If you wish to open freezer door immediately or shortly after closing it, you may feel rather strong resistance. When the freezer door is opened, some cool air escapes from the freezer compartment and it is replaced by warm air from the environment. When this air is cooled, a sub-pressure builds up, causing resistance to door opening. After a few minutes, the condition is normalized and the door can be easily opened again.</li> </ul>
Occurrence of murmur after closing the door:	<ul style="list-style-type: none"> <li>• After closing the door, some murmur can occur. This phenomenon is normal and is due to pressure equalisation.</li> </ul>

If none of the above reasons seems to match your problem, please contact the nearest service center and state the type, model and serial number as indicated on the label with basic information attached in the appliance interior.

## Noise

Cooling in refrigerating-freezing appliances is enabled by the refrigerating system with compressor, which produces noise. How noisy the appliance is depends on where it is placed, how it is used and how old the appliance is.

- **During the operation** of the compressor the noise of liquid is heard and when the compressor is not operating, the refrigerant flow is heard. This is a normal condition and it has no influence whatsoever on the lifetime of the appliance.

- **After starting the appliance**, the operation of the compressor and the refrigerant flow may be louder, which does not mean that something is wrong with the appliance and it has no influence on the lifetime of the appliance. Gradually the noise is reduced.
- Sometimes **unusual and stronger noise** is heard, which is rather unusual for the appliance. This noise is often a consequence of inadequate placing.  
(The appliance shall be placed and levelled firmly on solid base and it should not touch the wall or kitchen units standing next to it.)

WE RESERVE THE RIGHT TO ALTER THE SPECIFICATIONS WITH NO INFLUENCE ON THE OPERATION OF THE APPLIANCE.