

The appliance was designed and made in accordance with the European standards listed below:  
=> EN 30-1-1, EN 30-2-1 and EN 437 plus subsequent amendments (gas)  
=> EN 60 335-1 and EN 60 335-2-6 (electrical) plus relative amendments

The appliance complies with the prescriptions of the European Directives as below:  
=> 2006/95 EC concerning electrical safety (BT).  
=> 2004/108 EC concerning electromagnetic compatibility (EMC)  
=> 2009/142/CE concerning gas safety.

Oven accessories that could come into contact with foodstuffs are made with materials that comply with the provisions of the 89/109 EC directive dated 21/12/88.

This product complies with EU Directive 2002/96/EC.  
The crossed-out dustbin symbol reported on the appliance indicates that the appliance must be disposed of separately from other domestic refuse at the end of its useful life. It must therefore be delivered to a **waste recycling centre specifically for electric and electronic equipment or returned to the retailer at the moment of purchase of a new equivalent appliance.**



The user is responsible for delivering the appliance to the appropriate collection centre at the end of its **useful life, Failure to do so may result in a fine, as provided for by laws governing waste disposal.** Differential collection of waste products for eventual recycling, treatment and environmentally friendly disposal helps reduce possible negative effects on the environment and health, and also enables the materials making up the product to be recycled.

For more detailed information on the available refuse collection systems, refer to the local Municipal Solid Waste disposal centre or the shop where the product was purchased.

**Producers and importers are responsible for fulfilling their obligations as regards recycling, treatment and environmentally friendly disposal by directly or indirectly participating in the collection system.**

## CONTENTS

ASSISTANCE AND SPARE PART	3
IMPORTANT NOTES AND PRECAUTIONS FOR USE	4
DESCRIPTION OF THE APPLIANCE	5-11
INSTRUCTIONS FOR THE USER	12-24
TROUBLESHOOTING	25
TECHNICAL FEATURES	25-27
INSTRUCTIONS FOR THE INSTALLER	28-36

## ASSISTANCE AND SPARE PARTS

Before this appliance left the factory it was tested and fine-tuned by specialised expert personnel in order to guarantee its best functioning results.

**Any subsequent repairs or adjustments that may be necessary must be done with the maximum of care and attention by qualified personnel.**

For this reason we recommend you always contact our Service Centre specifying the brand, the model, its serial number and type of problem you are facing with it. All data related to your appliance are printed on the data label affixed on the appliance as well as on its original packaging.

A duplicate data label is contained in this booklet also. Please attach this label on the handbook or to an accessible surface near by the appliance for easy reference.

This information enables the technical assistant to come and visit you with the correct spares and guarantee a prompt and suitable service.

You will only find original spare parts at our Service Centre and authorised dealers.

SPACE FOR DATA LABEL

## IMPORTANT NOTES AND PRECAUTIONS FOR USE

You have purchased one of our products for which we thank you. We are confident that this new appliance, modern, functional and practical, made with top quality materials, will meet all your demands. This new appliance is easy to use but before installing and using it, it is important to read this handbook through carefully. It provides information for a safe installation, use and maintenance. Keep this handbook in a safe place for future reference.

The manufacturer reserves the right to make all the **modifications to its products that it deems necessary** or useful, also in your interests, without prejudicing its essential functional and safety characteristics. The manufacturer cannot be held responsible for any inaccuracies due to printing or transcription errors that may be found in this handbook.

N.B.: the pictures shown in the figures in this handbook are purely indicative.

- The installation, adjustments, conversions and maintenance operations listed in section «INSTRUCTIONS FOR THE INSTALLER» must only be carried out by qualified personnel.
- The installation of all-gas and combi appliances must comply with the standards in force.
- The appliance must only be used for its original purpose, that is, cooking for domestic use. Any other use is considered improper and, as such, dangerous.
- The manufacturer cannot be held responsible for any damage to persons or property resulting from an incorrect installation, maintenance or use of the appliance.
- Once the packaging has been removed from the outer surfaces and the various inner parts, thoroughly check that the appliance is in perfect condition. If you have any doubts do not use the appliance and call in a qualified person.
- The packaging materials used (cardboard, plastic bags, polystyrene foam, nails, etc.) must not be left with in easy reach of children because they are a potential hazard source. All packaging materials used are environmentally-friendly and recyclable.
- The electrical safety of this appliance is only guaranteed if it is correctly connected to a suitable earth system, as prescribed by the electrical safety standards. The manufacturer disclaims all responsibility if these instructions are not followed. Should you have any doubts, seek the assistance of a qualified person.
- Before connecting the appliance ensure that the rating plate data corresponds to that of the gas and electricity supply (see section «TECHNICAL FEATURES»).

The use of any electrical appliance requires certain fundamental rules to be observed:

- # Do not touch the appliance with wet or damp hands or feet.
- # Do not use the appliance when barefoot.
- # Do not pull the power cable to unplug the appliance from the mains socket.
- # Do not leave the appliance exposed to the atmosphere (rain, sun, etc.).
- # It is not envisaged that the unit is used by people (including children) with reduced physical, sensory or mental, by inexperienced or who lack familiarity with the product, unless supervised by a person responsible for their safety or have not received preliminary instructions on the use of the appliance.
- # Children must be supervised to make sure that they do not play with the appliance
- Before using the oven for the first time, heat and maintain at the maximum temperature for approximately two hours, while empty and with the door closed. This will expel the characteristic odour produced by the rock wool insulating material. Ventilate the room during this operation.
- During and after use, the glass of the oven door and the accessible parts may be very hot. Therefore, keep children away from the appliance.
- Keep the appliance clean. Food residues can be a fire hazard.
- When the oven is not in use, do not use it to store foodstuffs or containers: if it is accidentally turned on, it can cause damage and accidents.
- If an electrical socket near the appliance is used, ensure that the cables of any other electrical appliances do not come into contact with the oven and are at a sufficient distance from the hot parts of the oven.
- After using the appliance ensure that all the controls are in the off or closed position, and check that the "0" on the knob corresponds with the symbol "0" printed on the front panel.
- Before carrying out any kind of cleaning, adjustment, conversion or maintenance operation, disconnect the appliance from the electricity supplies.
- In case of problems and/or malfunction, turn off the appliance and disconnect it from the mains electricity supplies. Do not attempt to tamper with it. Any repairs, or adjustments must be carried out exclusively by qualified personnel. For this reason, we recommend that you to contact your nearest Service Centre specifying the model of your appliance and the type of problem.

## DESCRIPTION OF THE APPLIANCE

### PRESENTATION

Our cookers can be fitted with different types of hob: all gas, combined with heating elements in cast iron or all electrical, with heating elements in ceramic glass.

Each knob on the front panel has a diagram printed above it showing to which burner or heating element it refers. The combination of the different sized burners and electric heating element offers the possibility of various types of cooking.

Our cookers can be fitted with different types of oven: all gas, a gas/electricity combination and all electrical. The latter can be either conventional or forced type (with fan).

To guarantee the customer a good and safe use of the appliance, the combined and all electrical cookers, have equipped with a safety temperature device, which automatically turns on in case the main thermostat fails to work. In such an event, the electricity is interrupted temporarily: **do not attempt to repair it yourself but turn the appliance off and contact your nearest Assistance Centre.**

The oven walls are fitted with various runners (fig. 1) on which the following accessories can be placed.

Supply and quantities vary from model to model:

- oven shelf
- drip tray or drip pan
- set spit (\*)

(\*) Only certain versions.

The cookers can be fitted with a small compartment under the oven that can be used for storing things. Remember that the surfaces become hot, it is **strictly forbidden to place inflammable materials inside.**

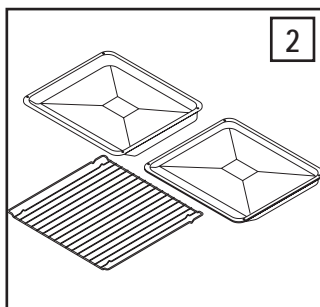
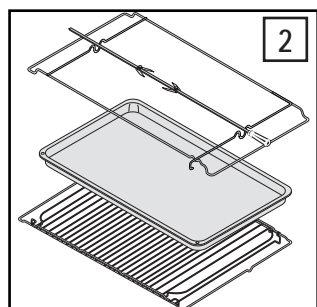
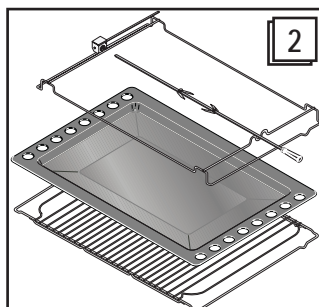
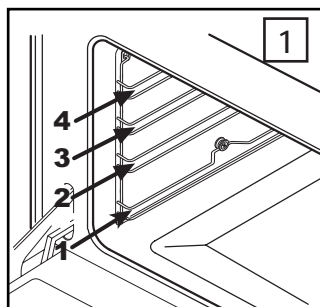
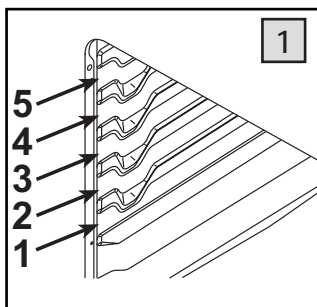
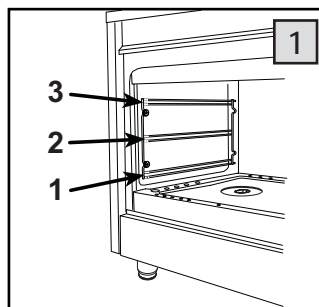
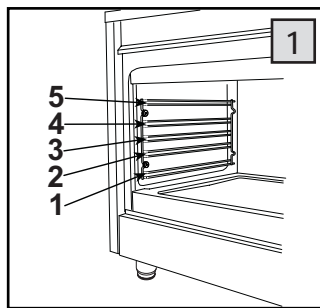

# DESCRIPTION OF THE APPLIANCE

## DESCRIPTION OF THE CONTROLS

### ENERGY REGULATOR KNOB (A) - single cooking zone

By turning the knob to the right or to the left we find the following symbols:

0 = heating elements off

from 1 to 12 = minimum and maximum power

### ENERGY REGULATOR KNOB (B) - double cooking zone

By turning the knob to the right we find the following symbols:

0 = heating elements off

from 1 to 12 = minimum and maximum power for single cooking zone

from 12 to 0 = maximum power for double cooking zone

### HOB GAS BURNER KNOB (C)

By rotating the knob in an anticlockwise direction, the following symbols appear:

0 = Closed position

  = "Full on" position

 = "Reduced rate" position

### HOB ELECTRIC PLATE KNOB (D)

By rotating the knob in a clockwise or an anticlockwise direction, the following symbols appear:

0 = Electric plate off



from 1 to 6 = Positions from minimum to maximum power

### GAS OVEN/GRILL THERMOSTAT KNOB (E)

By rotating the knob in an anticlockwise direction, the following functions appear:

0 = Closed position

from Min. to Max  
(from 125/155°C to 255/260°C) = Oven temperatures

Turn the knob clockwise if you want to use the gas or electric grill  / .

### COMMUTATOR/THERMOSTAT KNOB FOR THE ELECTRIC CONVENTIONAL OVEN (F)

By turning the knob clockwise we will find the following symbols:

0 = Oven off

 = Oven light on, which stays on for all functions

from 50°C to Max = The different oven temperature values

 = Grill + spit heating element on (\*)

 = Top heating element on

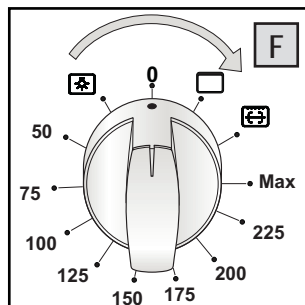
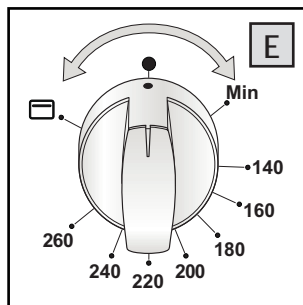
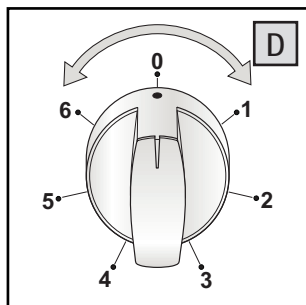
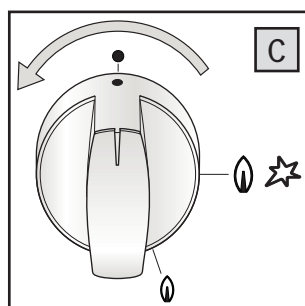
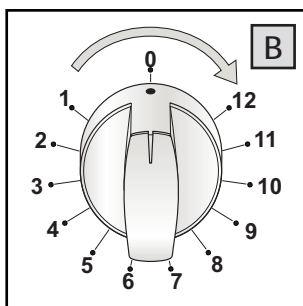
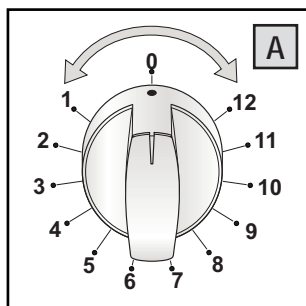







## DESCRIPTION OF THE APPLIANCE

### THERMOSTAT KNOB FOR THE FAN OVEN (G)

By turning the oven knob clockwise we will find the different oven temperature values (from 50°C to Maxi).









### FAN OVEN FUNCTION SELECTOR KNOB (6) (H)

By turning the knob to the right or to the left we will find the following symbols:

- 0 = Oven off
-  = Oven light on, which stays on for all functions
-  = Fan on
-  = Top and bottom heating elements on
-  = Top and bottom heating elements and fan on
-  = Grill + spit heating element on (\*)
-  = Grill heating element and fan on

### FAN OVEN FUNCTION SELECTOR KNOB (8) (H)

By turning the knob to the right or to the left we will find the following symbols:

- 0 = Oven off
-  = Oven light on, which stays on for all functions
-  = Fan on
-  = Top and bottom heating elements on
-  = Top and bottom heating elements and fan on
-  = Bottom heating element and fan on
-  = Rear heating element and fan on
-  = Grill + spit heating element on (\*)
-  = Grill heating element and fan on

 OVEN LIGHT SWITCH

 SPIT ROAST SWITCH (\*)

 FAN SWITCH (\*)

 BURNER IGNITION BUTTON (\*)  
(\*) only certain versions

### RED WARNING LIGHT

If present, when lit it indicates that one or more of the hob electric plates is on, if the hob is mixed, or one of the oven electric components.

### YELLOW WARNING LIGHT

If present, when lit it indicates that either the electric oven or electric grill is working. While the oven is being used the light will switch off when the set temperature is reached. During baking it is normal for the yellow light to switch on and off several times as the oven temperature is controlled.

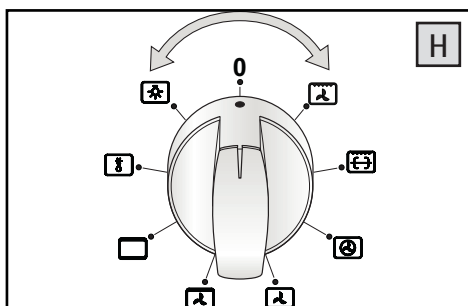
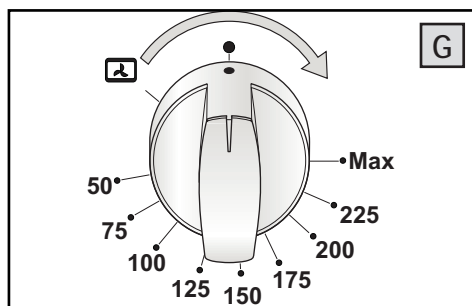
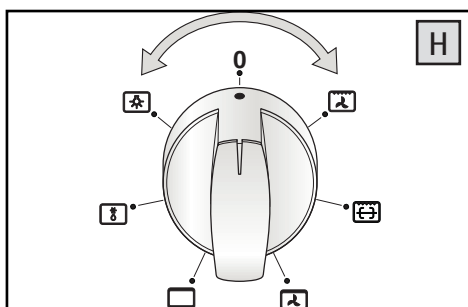

# DESCRIPTION OF THE APPLIANCE

## DESCRIPTION OF DIFFERENT ACCESSORIES

### TIMER

To set cooking time, first wind the timer up by turning it completely once from left to right and then back to the number of minutes you want. The timer will ring when the set time has elapsed.

### TIMER WITH COOKING TIME

This accessory has a dual function: it signals how much cooking time has elapsed and it also turns the oven off automatically. N.B.: When the pointer of the knob is on «\*» position, the oven cannot work.

If you use the oven without any programming, check that the timer is on the manual position.

### Semi-automatic operation

After having selected a cooking, to set cooking time, first wind the timer up by turning it completely once from left to right and then back to the number of minutes you want, from 0 to 120 minutes: the oven will switch on. Once the programmed time has elapsed the buzzer will ring and the end of cooking time device triggers.

### Manual operation

If the cooking time is more than 2 hours, or if you want to use the oven without the timer, turn knob from right to left until the pointer is on the  symbol.

When the food is cooked do not forget to move the knob pointer round to position «\*».

### ANALOGICAL CLOCK

This clock has a dual function: a clock and minute minder.

#### Setting the time

Subsequent to wiring or after a power cut, press and turn knob (M) clockwise to set the time.

#### Minute minder

Turn knob (M) clockwise without pressing it and select the length of time wanted (up to 50 minutes). When the set time has elapsed the buzzer will sound: turn the knob round to the  symbol to stop it.

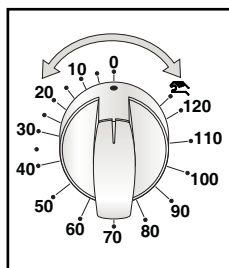
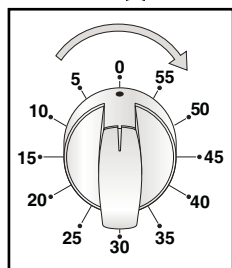



### ELECTRONIC CLOCK

This accessory functions as a clock and a minute counter. The digital display (L) always shows the time but will display the minute counter time when this function is set.

#### Setting the time (from 0.01 to 24.00 - hh,mm)

After connecting to the electricity mains or subsequent to a power cut the figures "0.00" will flash on the display. Press push button 1 and start setting the current time by pressing push button 2 or 3. The function will start 7 seconds after setting.

#### Minute counter (from 0.01 to 0.99 = hh,mm)

By selecting the time on the minute counter with push button 3, this function will be active all of the time (time is set in 10 second units). The time will disappear leaving the minute counter time showing on the display and the  symbol lights up. Time is given in seconds during countdown. At the end of the set time the buzzer goes off, the  symbol disappears and the time reappears. You can see the time while the minute counter is functioning by pressing push button 1.

### Buzzer

The buzzer goes off at the end of the minute counter function and lasts about 7 minutes. The buzzer can be stopped by pressing button 3.

### Buzzer intensity

There are three different buzzer intensities: to select the one you want press push button 2 when the time is displayed.

### Correcting/cancelling the minute counter function

To correct or cancel the time set on the minute counter, press keys 2 and 3 simultaneously and then release key 3 first. The time can be corrected at any moment by pressing push button 1 followed by 2 or 3.

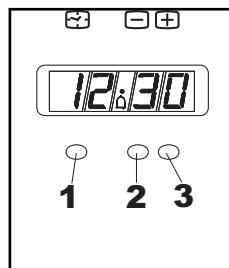
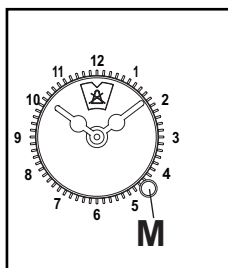

## DESCRIPTION OF THE APPLIANCE

### ELECTRONIC CLOCK WITH COOKING TIME

This timer has two different functions: a clock function and one that automatically stops the oven by setting the length of cooking time.

The digital display always shows the time but will also show timer time when this function is set.

#### Setting the time (from 0.01 to 24.00 = hh,mm)

After connecting to the electricity mains or subsequent to a power cut either the figures "0.00" or the time elapsed since electricity was returned, will flash on the display. Press push button 1 and start setting the current time by pressing button 2 or 3.

While you are setting the time the manual functioning mode symbol  will turn on. The function will start 7 seconds after setting.

#### Manual operation

By simply setting the time (push button 1) or when the buzzer is interrupted (push button 3) the timer is programmed on the manual functioning mode which is confirmed when the  symbol turns on. To the contrary, the manual functioning mode is only possible at the end of semi-automatic programming or after having cancelled it.

#### Semi-automatic operation (with cooking time from 0.01 to 0.99 = hh,mm)

By selecting the time on the minute counter with push button 3 this function will always be active (the time is set in 10 second units).

The time will disappear from the display leaving the minute counter time and the  symbol showing and the AUTO symbol will turn on. The time units are in seconds during count down.

At the end of the set time the buzzer will ring, the AUTO and  symbols will turn off and the time reappears. The time can be seen during this function by pressing push button 1.

#### Buzzer

The buzzer goes off at the end of the minute counter function and lasts about 7 minutes. The buzzer can be stopped by pressing button 3. After having done this remember to turn the selector knob and the thermostat round to the off position.

#### Buzzer intensity

There are three different buzzer intensities: to select the one you want press push button 2 when the time is displayed. Manual function programming is now cancelled.

#### Correcting/cancelling functions

To correct or cancel the time set on the timer, press keys 2 and 3 simultaneously and then release key 3 first. The time can be corrected at any moment by pressing push button 1 followed by 2 or 3.

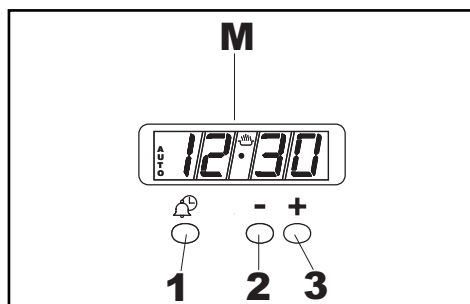



## DESCRIPTION OF THE APPLIANCE

### ELECTRONIC PROGRAMMER

This accessory has the following functions:

- Clock (set by keys 2 and 3)
- Timer (set by key 1)
- Cooking time (set by key 2)
- End of cooking time (set by key 3)
- Manual operation settings (set by keys 2 and 3)
- Setting time backwards (set by key 4)
- Setting time forward (set by key 5)

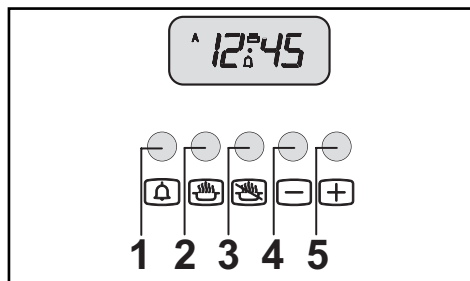

The digital display always shows the time and can be set to show cooking time or end of cooking count-down simply by pressing the corresponding key.

**Please Note:** When the cooking session is over the programme automatically turns off the oven (except for the timer). Should you wish to proceed manually next time you use the oven, make sure you set the manual operation function (see instructions further on).

#### Time setting (0:01 to 24:00 = hh,mm)

When plugging in the appliance the first time or subsequent a power cut, the display shows both "A" and "0.00" (or the minutes past the power failure) signs flashing.

To reset the time push keys 2 and 3 simultaneously then press key 4 or 5 till you reach the exact current time. When done, the "A" symbol turns off and the manual operation symbol is lit.

#### Manual operation

Each time the time is set, the programme sets automatically on manual working order. The only other case when this occurs is when an automatic programme reaches completion, or has been cancelled by pressing keys 2 and 3 at the same time. The "A" symbol disappears and the turns on.

#### Timer setting (0:01 to 0:59 = hh,mm)

Press key 1 and select cooking time by pushing key 4 or 5. Symbol turns on. Once the time set is expired the acoustic alarm rings and turns off.

#### Semi-automatic working order (cooking period from 0:01 to 23:59 = hh,mm)

Press key 2 and set cooking time by keys 4 or 5; both symbols "A" and are lit. Once the set period is over, turns off, "A" flashes and the buzzer rings.

#### Semi-automatic working order (setting end of cooking from 0,01 to 23,59 = hh,mm)

Press key 3 and set the end of your cooking session by key 5; both symbols "A" and turn on. Once the set hour is reached, turns off, "A" flashes and the buzzer rings.

#### Automatic operation (with a delayed start)

Set the cooking period first ("A" and turn on) then set the end of cooking time ( turns off) as previously described. Symbol turns on again when at the start of cooking session. When cooking time is over, turns off, "A" flashes and the buzzer will advice cooking completion.

#### Buzzer

The buzzer starts ringing when a cooking session has reached its completion or the timer countdown is over. It can ring up to 7 minutes. Press any function key to make it stop beforehand.

#### Programme start and control

The programme starts immediately after setting. To check settings of the programme press the corresponding key.

#### Modify or Cancel programme setting

In case the current time displayed on the clock is within the cooking period set, an error in the automatic function occurs, and both the buzzer ring and the flashing «A» draw your attention. Such error in the set up can be amended by varying the cooking time length or its end. Any programme set can be modified at any time by pressing first its corresponding programme key and then key 4 or 5. To cancel a programme, correct the time set bringing it to a value of "0.00". When functioning time is cancelled the end of functioning is cancelled too and vice versa. The oven turns off automatically and the "A" symbol flashes.

## DESCRIPTION OF THE APPLIANCE

### ELECTRONIC PROGRAMMER

The programmer can select the following functions:

- Clock (set by keys 2 and 3)
- Minute counter (set by key 1)
- Cooking time (set by key 2)
- End of cooking (set by key 3)
- Manual operation mode (set by key 4)
- Setting time backwards (set by key 5)
- Setting time forward (set by key 6)

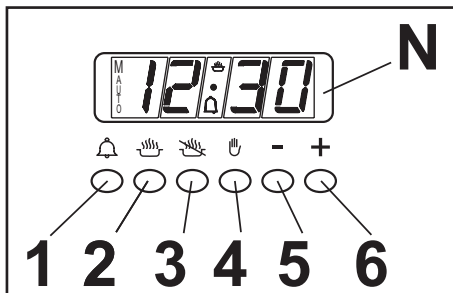

The digital display (N) always shows the time and can display cooking and end of cooking time or the minute counter time by pressing the corresponding push button.

**N.B.:** At the end of each setting session (except for the minute counter) the programmer turns the oven off. Check when next using the oven, if the programmer is not going to be used, that the latter is set on manual operation (see the instructions given further on).

#### Setting the time (from 0.01 to 24.00 = hh,mm)

After connecting to the electricity mains or subsequent to a power cut, AUTO and "0.00" will both flash simultaneously on the display.

Press push buttons 2 and 3 simultaneously and start setting the current time by pressing push button 5 or 6. Once set the AUTO symbol will turn off and the symbol, for manual operation, will turn on.

#### Minute counter (from 0.01 to 0.59 = hh,mm)

Press push button 1 and select cooking time with push button 5 or 6. The symbol turns on. At the end of the set time the buzzer will go off and the symbol turns off.

#### Semi-automatic operation

(with cooking time from 0.01 to 23.59 = hh,mm)

By pressing push button 2 and setting the length of cooking time with push button 5 or 6, the AUTO and symbols will light up and stay on all the time. At the end of the set time the symbol will turn off, the AUTO symbol will flash and the buzzer will go off.

#### Semi-automatic operation

(with end of cooking time from 0.01 to 23.59 = hh,mm)

By pressing push button 3 and setting the end of cooking time with push button 6, the AUTO and symbols will turn on and stay on all the time. At the end of the set time the symbol will turn off, the AUTO symbol will flash and the buzzer will go off.

#### Automatic operation

(with the start of cooking time delayed)

First programme cooking time (both the AUTO and symbol will turn on) and then the end of cooking time (the symbol will turn off) as described previously. The symbol will turn on again when baking in the oven starts. At the end of cooking time the symbol will turn off, the AUTO symbol will flash and the buzzer will go off.

#### Manual operation

Manual operation is only possible when the automatic programming has finished or after having cancelled it by pressing push button 4. The AUTO symbol disappears and the symbol turns on.

#### Buzzer

The buzzer will go off at the end of a programme or at the end of the minute counter function and lasts about 7 minutes. The buzzer can be stopped by pressing one of the function push buttons.

#### Programme start and control

The programme starts after setting. The programme set can be controlled at any time by pressing the corresponding push button.

#### Correcting/cancelling the programme setting

An automatic function programming error will occur if the time shown on the clock is between the cooking start time and cooking end time. This error will be signalled immediately by a buzzer and the AUTO symbol will flash. A setting error can be corrected by altering the duration or end of cooking time. Any programme that has been set can be corrected at any time by pressing the corresponding programming key and then key 5 or 6. To cancel a programme, correct the time set bringing it to a value of "0.00". If functioning time is cancelled the end of functioning is cancelled too and vice versa. The oven turns off automatically and the AUTO symbol flashes. Press key 4 to set the programmer on manual operation. The right time cannot be corrected when the automatic operation programme is working.

# INSTRUCTIONS FOR THE USER

## HOB: GENERAL NOTES ON SAFETY

- When using the burners or the heating elements, do not leave the appliance unsupervised. Ensure that children do not play with the appliance. In particular, make sure that pan handles are positioned correctly and supervise the cooking of foods which use oils and fats, as these are highly inflammable.
- Do not use aerosols or sprays near the appliance when it is in use.
- If the appliance is fitted with a lid, remove any food residues on the surface before opening.
- If the appliance is fitted with a crystal glass lid, this can shatter when heated. Turn off all the burners or disconnect all heating elements and to attend that is cooled, before closing the lid (fig. 6).
- Even after use, the burners or the heating elements remain hot for a long period; to avoid burning, do not place hands or other objects on them (on the ceramic glass hobs, pay attention to the "residual heat warning").
- If a crack appears on the surface of the ceramic glass or electric plate, disconnect the appliance from the electricity supply immediately.
- After using the appliance, ensure that all the controls are in the closed or off position.

When a gas cooker is being used it produces heat and humidity in the room where it is installed. For this reason the room must be well ventilated, **keeping the natural ventilation openings free (fig. 19)** and switching on the mechanical aeration system (suction hood or electric fan, figs. 20 and 21). If the cooker is used for a long time additional aeration may be necessary, for instance, opening a window, or a more effective aeration by increasing the power of the mechanical system if there is one.

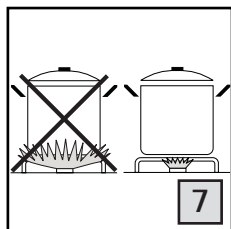

## LIGHTING THE BURNERS

### a) Manual ignition

Press and turn counterclockwise the knob (C) corresponding to the burner you wish to use, until it reaches to the "Full on" position and placing a lighted match to the burner.

### b) Electric ignition of the burners (only certain versions)

Press and turn counterclockwise the knob (C) corresponding to the burner you wish to use, until it reaches to the "Full on" position and simultaneously press and release the ignition button \* . Matches can be used to light the burners in a blackout.

### c) Automatic electric ignition of burners (only certain versions)

Push lightly the knob (A) corresponding to the burner you wish to use and turn counterclockwise to the "Full on" position, then depress the control knob. Automatically the ignition spark shoots. Matches can be used to light the burners in a blackout.

### d) Lighting of burners equipped with safety thermocouples (only certain versions)

In the case of burners equipped with safety thermocouples you have to turn counterclockwise to the "Full on" position, the knob (C) corresponding to the burner you wish to use, then press the knob and repeat the operations described previously. Once lit, keep the knob pressed for about 10 seconds.

### e) Optimum use of the burners

To get the maximum yield with the minimum consumption of gas it is handy to keep the following points in mind:

- Once the burner has been lit, adjust the flame according to your needs.
- Use an appropriately sized pan for each burner (see the table below and fig. 7).
- When the content of the pan start to boil, turn the knob down to "Reduced rate position" (small flame).
- Always put a lid on the pan.

Burners	Ø pan cm
Ultrarapid	22÷24
Rapid	20÷22
Semi-rapid	16÷18
Auxiliary	12÷14

# INSTRUCTIONS FOR THE USER

## SWITCHING THE ELECTRIC PLATES ON

The cookers can be fitted with fast electric hotplates, indicated with a red label.

The hotplates are controlled by a 6-position switch (C). They are switched on by turning the knob to the required position. A red coloured warning light signals that the plates are on. The rapid hotplates offer the advantage of ultra-rapid cooking.

**N.B.:** Before using the hotplate for the first time or if it has not been used for a long period, the hotplate control knob must be set at the no. 1 position for 30 minutes, in order to eliminate possible humidity absorbed by the insulating material.

## SWITCHING THE HEATING ELEMENTS

The cooking zones are clearly visible on the hob, being circular. Only the inside of the circles traced on the glass is heated.

The hob has a built-in warning light that switches on when the temperature in the cooking zone exceeds 60°C. This warning light will only switch off when the temperature in the cooking zone has gone below this value and it is for this reason it is called the "residual heat warning".

The heating elements with a single cooking zone, are controlled by energy regulators with 12 positions (A) that permit to obtain a big range of different temperatures.

The heating element with a double cooking zone, are controlled by 12-position energy regulators (B).

By turning the knob from 1 to 12, the powers of the first zone of cooking "1" are regulated. By turning besides the number 12, a release it is warned that signals the insertion of the second zone of cooking "2" (fig. 8).

In this position, both work the zone of cooking to the maximum power. By turning the knob counterclockwise to regulate its power.

Only returning on the position "0" the second zone of cooking is disconnected.

A red coloured warning light signals that the heating elements are on.

## GENERAL INFORMATION AND INSTRUCTIONS FOR USING CERAMIC GLASS HOBS

- Ceramic glass is a natural product and, like any other material in ceramic, can have an uneven surface. You might even see some bubbles inside the ceramic glass itself: these will not influence cooking or the lifetime of the hob.
- Illumination of the single cooking zones might differ. This depends on the technical characteristics of the heating elements. This has absolutely no effect on quality or operation.
- According to how you look at it, the incandescent heating might appear to go over the edge of the cooking zone.
- Do not put very hot pans on the outer edge of the hob.
- **Do not use pans with aluminum bottom.**
- Do not use the hob as a work top and take care not to let hard or sharp objects fall on it. The top could be damaged.
- Do not put empty enamelled pans on the heat. Both the bottom of the pan and the ceramic glass could be damaged.
- Do not drag pans or other objects over the glass top which could get scratched.
- Clean and dry the bottom of the pan before putting it on the hob. Salt, sugar or grains of sand, for example, that could be in greens, can scratch.
- Clean off immediately any spilled liquid.
- Do not cook or reheat food wrapped in tin foil or plastic containers. Both the tin foil and the plastic containers would melt, sticking to the hob.

**N.B.:** Using the glass scraper, push immediately away from the cooking zone, any pieces of tin foil or plastic objects that could have melted or stuck; likewise sugar or sugary food spilled over during cooking.

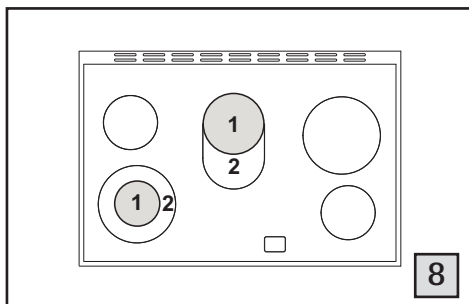

## INSTRUCTIONS FOR THE USER

### HOW TO SAVE ELECTRICITY

To get the maximum yield with the minimum consumption of electricity it is recommended to keep the following points in mind:

- Switch the hob heating element on only after you have put the pan on the cooking zone or plate
- Thoroughly dry the bottom of the pan before putting it on the cooking zone or plate.
- Do not use pans with a diameter that is less than that of the cooking zone or plate (fig. 9). When you are buying saucepans keep in mind that the manufacturer usually gives the largest diameter of the pan which is normally bigger than the base diameter.
- Use pans with flat, thick bottoms (see fig. 9). Bottoms that are not flat will make cooking times longer.
- Always put a lid on the pan (fig. 9).
- If cooking time is longer than 40 minutes you can switch the plate off 5 to 10 minutes before the end of cooking time and make use of the residual heat.
- For your information only, the table gives hints on how to use the cooking zones and plates.

Position of knobs		Heat intensity	Possible cooking processes
0	0	Off	
1	1-2	Low	To dissolve butter, chocolate, etc. To heat small amounts of liquid.
2	3-4	Moderate	To heat greater quantities of liquid.
3	5-6	Slow	Thawing frozen food and preparing stews, boiling or simmering.
4	7-8	Medium	Bringing foods to boiling point. For delicate roasts and fish.
5	9-10	Strong	For roasts, chops and steaks. For large amounts of boiled meat.
6	11-12	Hot	Bringing large amounts of water to the boil. Frying.

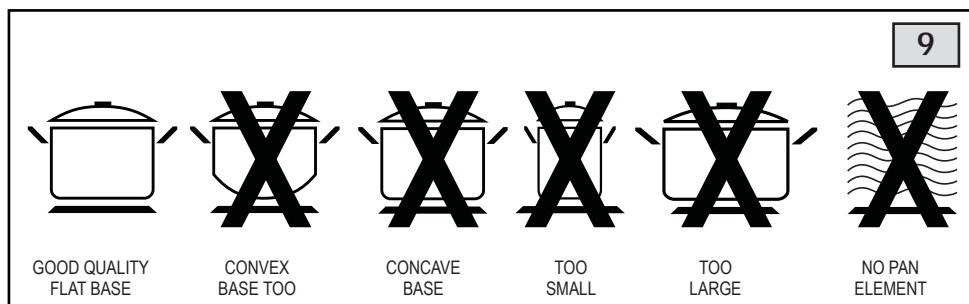

## INSTRUCTIONS FOR THE USER

### OVEN: GENERAL SAFETY INSTRUCTIONS

- Do not leave the oven unsupervised during use. Ensure that children do not play with the appliance.
- Always keep the appliance lid open when using the oven, in order to prevent overheating.
- Always grip the centre of the oven door when opening. Do not practice excessive pressures on the door when it is open.
- Do not worry if condensation forms on the door and on the internal walls of the oven during cooking. This does not compromise its efficiency.
- When opening the oven door, be very careful of scalding vapours.
- The appliance becomes very hot during use. Do not touch the heating elements inside the oven. Wear oven gloves when placing or removing pans from the oven.
- When removing the tray from the oven, always use the grill pan handle (fig. 3) (if provided). Hook the handle to the edge of the tray and pull it out, slightly lifting it as you do so.
- When inserting or removing food from the oven, check that excess juices do not overflow onto the oven base (oils and fats are highly inflammable when overheated).
- Use containers that will resist the temperatures indicated on the thermostat knob.
- For good results during cooking, we strongly recommend not to cover the base of the oven or the grill with aluminium foil or other materials.
- When grilling always put a little water in the grill pan. The water prevents the grease from burning and from giving off bad smells and smoke. Add more water during grilling to compensate for evaporation.
- After using the appliance ensure that all the controls are in the off position.
- **WARNING!!!** During and after use, the oven door glass and the accessible parts can be very hot, therefore keep children away from the appliance.

#### **IMPORTANT!!**

Always keep the oven door closed during baking or grilling. It must only be left open when using the gas grill burner (see relative instructions).

### WHAT TO DO THE FIRST TIME YOU USE THE OVEN

If the appliance has a programming accessory, place it on the manual position, and, before cooking for the first time, ensure the oven is empty and its door closed, heat the oven at maximum temperature for 2 hours. This will allow the protective coating on the interior of the oven to be burnt off and dissipate the associated smells. During this time do not stay in the same room and keep it aerated.

After the hour or so has elapsed leave the oven to cool down and then clean its interior with hot water and a mild detergent. Also wash the accessories (shelves, trays, drip pan, spit..) prior to use.

Prior to any cleaning, disconnect the appliance from the electricity mains.

# INSTRUCTIONS FOR THE USER

## HOW TO USE GAS OVEN AND GRILL

The oven and grill burner can be fitted with a safety thermocouple so, once the burner has been lit, keep the knob pressed for about 15 seconds. If, at the end of this time, the burner fails to light, release the knob and wait at least 1 minute before trying again. Should the burner turn out accidentally, turn the knob round to the closed position and wait at least 1 minute before lighting it again.

### MANUAL IGNITION OF THE OVEN BURNER

Open the oven door press and turn the oven knob (E) counterclockwise until it reaches to the maximum temperature position, simultaneously placing a lighted match to the burner through the hole (B) (fig. 10).

### ELECTRIC IGNITION OF THE OVEN BURNER (only certain versions)

Open the oven door press and turn the oven knob (E) counterclockwise until it reaches to the maximum temperature position and simultaneously press and release the ignition button \*. Matches can be used to light the burners in a blackout.

### AUTOMATIC ELECTRIC IGNITION OF BURNERS (only certain versions)

Open the oven door push lightly the oven knob (E) and turn counterclockwise until it reaches to the maximum temperature position, then depress the knob. Automatically the ignition spark shoots. Matches can be used to light the burners in a blackout.

After the oven burner has been lit (check through the opening (C) (fig. 10) that it has ignited), adjust the temperature according to your needs and leave open the oven door for 2 to 3 minutes. Close the door gently so the flames will not blow out and wait 15 minutes before putting any food in to cook. Our oven can cook all foods (meat, fish, bread, pizza, cakes, etc.).

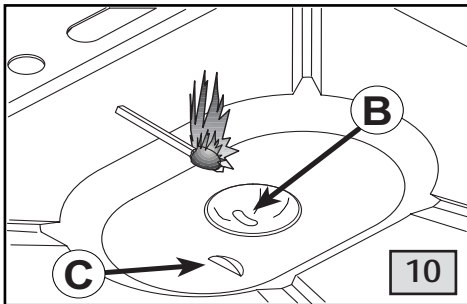

### MANUAL IGNITION OF THE GRILL BURNER

Open the oven door press and turn the oven knob (E) clockwise to the grill position ; simultaneously placing a lighted match to the burner on the oven's ceiling.

### ELECTRONIC LIGHTING OF THE GRILL BURNER (only certain versions)

Open the oven door press and turn the oven knob (E) clockwise to the grill position  and simultaneously press and release the ignition button \*. Matches can be used to light the burners in a blackout.

### AUTOMATIC ELECTRICAL IGNITION OF BURNERS (only certain versions)

Open the oven door push lightly the oven knob (E) and turn clockwise to the grill position , then depress the knob. Automatically the ignition spark shoots. Matches can be used to light the burners in a blackout.

When the gas grill burner is lit the oven door must be left open. To prevent the knobs and components from overheating you must always put the shield on (fig. 11).

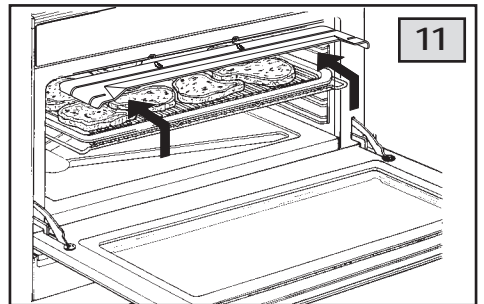
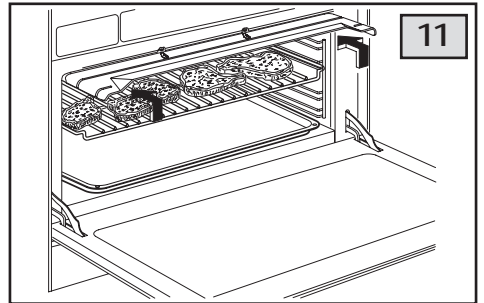

# INSTRUCTIONS FOR THE USER

## HOW TO USE GAS OVEN AND ELECTRIC GRILL

The oven burner can be fitted with a safety thermocouple so, once the burner has been lit, keep the knob pressed for about 15 seconds. If, at the end of this time, the burner fails to light, release the knob and wait at least 1 minute before trying again. Should the burner turn out accidentally, turn the knob round to the closed position and wait at least 1 minute before lighting it again.

### MANUAL IGNITION OF THE OVEN BURNER

Open the oven door press and turn the oven knob (E) counterclockwise until it reaches to the maximum temperature position, simultaneously placing a lighted match to the burner through the hole (B) (fig. 10).

### ELECTRIC IGNITION OF THE OVEN BURNER

(only certain versions)

Open the oven door press and turn the oven knob (E) counterclockwise until it reaches to the maximum temperature position and simultaneously press and release the ignition button . Matches can be used to light the burners in a blackout.

### AUTOMATIC ELECTRIC IGNITION OF BURNERS

(only certain versions)

Open the oven door push lightly the oven knob (E) and turn counterclockwise until it reaches to the maximum temperature position, then depress the knob. Automatically the ignition spark shoots. Matches can be used to light the burners in a blackout.

After the oven burner has been lit (check through the opening (C) (fig. 10) that it has ignited), adjust the temperature according to your needs, close the door gently so the flames will not blow out and wait 15 minutes before putting any food in to cook. Our oven can cook all foods (meat, fish, bread, pizza, cakes, etc.).

## SWITCHING THE ELECTRIC GRILL

Turn the oven knob (E) round to the symbol .

The red warning light will come on to indicate that the grill heating element has been activated.

The top heating element is turned on and it distributes heat directly onto the food. When the grill turns on so will the eventual spit motor.

Besides grilling, it can be used to slightly brown cooked food.

An automatic thermostat regulates the inner temperature, therefore, do not use the grill immediately after a cooking in the oven.

Always keep the oven door closed during the use of the electric grill.

## COOKING WITH THE AID OF THE FAN

Some cookers can be equipped with a fan installed in the rear part of the oven compartment. This can be activated by pressing the fan switch .

After the fan has been activated, the heat will be quickly and regularly distributed throughout the oven, thus allowing different foods to be evenly cooked on several shelves at the same time, also reducing the cooking times.

Note that the fan can be activated during all oven cooking functions, except in the function gas grill



# INSTRUCTIONS FOR THE USER

## HOW TO USE THE CONVENTIONAL OVEN



### TRADITIONAL COOKING

Turn the commutator/thermostat knob (F) on the temperature required. If pre-heating is recommended wait till the thermostat yellow warning light turns off before placing foods inside the oven. Both the bottom and top heating elements are turned on, distributing heat to the food from the top and bottom. This type of baking is ideal for all types of food (meat, fish, bread, pizza, cakes..).



### GRILL COOKING

Turn the commutator/thermostat knob (F) on the symbol.

The top heating element is turned on and it distributes heat directly onto the food. Besides grilling, it can be used to obtain a golden finish onto cooked foods or to toast your bread slices.

The grill function automatically activates the eventual spit. When you use the grill, do not forget to place the drip pan beneath the spit to collect any sauce dripping, as suggested in the "COOKING TIPS" section.



### BROWNING BY TOP HEATING ELEMENT

Turn the commutator/thermostat knob (F) on the symbol.

The top peripheral heating element is turned on that distributes heat directly onto the food.

This function is particularly suitable for delicately browning the top of food or for toasting bread.

## HOW TO USE THE MULTIFUNCTION OVEN



### DEFROSTING AT ROOM TEMPERATURE

Turn the selector knob (H) to the symbol and place the food you want to defrost inside the oven. The length of time required depends on the quantity and type of food.

Selecting this function will only activate the fan. Mild air circulation around frozen food will slowly defrost it. It is particularly suitable for fruit and cakes.



### TRADITIONAL COOKING

Turn the selector knob (H) to the symbol and adjust the thermostat knob (G) to suit the desired temperature.

If pre-heating is recommended wait till the thermostat yellow led turns off before placing foods inside the oven. This option turns on both bottom and top heating units, evenly distributing heat on your foods.

This type of cooking is ideal for all kind of foods (meats, fish, bread, pizzas, cakes..).



### COMBINED TRADITIONAL + FAN COOKING

Turn the selector knob (H) to the symbol and adjust the thermostat knob (G) to suit the desired temperature.

If pre-heating is recommended wait till the thermostat yellow led turns off before placing foods inside the oven. This option turns on both bottom and top heating units, and heat is distributed by fan ventilation.

This combination is suitable for rapid cooking and allows for the use of more plates positioned on the different levels of the oven.



### DEFROSTING + WARM UP BY HOT AIR

(available only on 8 multifunctions ovens)

Turn the selector knob (H) to the symbol and set the temperature on the thermostat knob (G), now place the food inside the oven. Selecting this function will activate the bottom heating unit and its heat is distributed by the fan. This function is particularly recommended to defrost and warm up ready-made meals.

# INSTRUCTIONS FOR THE USER



## FAN + REAR HEATING COMBINED COOKING (available only on 8 multifunctions ovens)

Turn the selector knob (H) to the symbol and set the thermostat knob (G) to the desired temperature, then place your food the oven. If oven needs pre-heating wait till the thermostat yellow led turns off before placing foods inside it. This function activates the rear heating unit and the fan distributes the heat produced. This combination allows for a fast and even cooking of several different foods placed on the diverse levels of the oven.



## CONVENTIONAL GRILL COOKING

Turn the selector knob (H) to the symbol and set the thermostat knob (G) to the desired temperature.

Selecting this function the top central heating element turns on and heat is distributed directly on food surface.

Apart from grilling, this function is ideal to add a golden roast to your recipes or to toast bread slices.

The grill function automatically activates the eventual spit. When you use the grill, do not forget to place the drip pan beneath it to collect any sauce dripping, as suggested in the "USEFUL COOKING TIPS " section.



## FAN GRILL COOKING

Turn the selector knob (H) to the symbol and set the thermostat knob (G) to the desired temperature.

Selecting this function the top central heating element turns on and heat is distributed by the fan. This procedure mitigates the direct heat on food surface and uses milder temperatures. It is therefore recommended for an even golden and crispy finish touch, ideal for whole fish and poultry.

When you use the grill, do not forget to place the drip pan beneath it to collect any sauce dripping, as suggested in the "USEFUL COOKING TIPS " section.

## HOW TO USE THE SPIT (fig.12)

- Place the chicken or piece of meat to roast firmly between the two forks on the spit and make sure it is evenly balanced to prevent straining the motor.
- Rest the spit on the support introducing the end in the seat and unscrew and remove the hand grip from the spit.
- Fit support into the runner number four (starting from the bottom), minding the lever is in position B. Insert its end into the relative motor coupling, moving the lever to position A
- Close the oven door, turn the oven knob on the symbol. When the grill turns on, the spit turn too.
- Once the cooking is finished, remove the spit, moving the lever to position B
- Always use the drip pan to catch the gravy, as indicated in the paragraph "USEFUL COOKING TIPS".
- Gas grill burner: position the oven knob on the symbol and light the grill burner. Start the spit motor with the spit roast switch .

Always keep the oven door closed during electric grilling.  
It must only be left open when using the gas grill burner (see relative instructions)

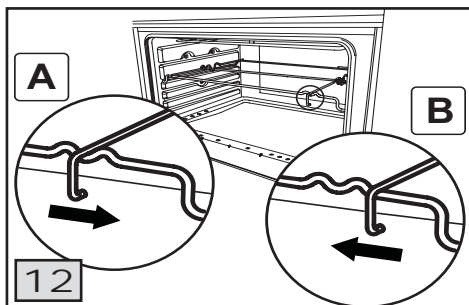

# INSTRUCTIONS FOR THE USER

## USEFUL COOKING TIPS

### Cakes and bread:

- Heat the oven for at least 15 minutes before you start cooking bread or cakes.
- Do not open the door during baking because the cold air would stop the yeast from rising.
- When the cake is cooked turn the oven off and leave it in for about 10 minutes.
- Do not use the enamelled oven tray or drip pan, supplied with the oven, to cook cakes in.
- How do you know when the cake is cooked? About 5 minutes before the end of cooking time, put a cake tester or skewer in the highest part of the cake. If it comes out clean the cake is cooked.
- And if the cake sinks? The next time use less liquids or lower the temperature 10°C.
- If the cake is too dry: Make some tiny holes with a toothpick and pour some drops of fruit juice or spirits on it. The next time, increase the temperature 10°C and set a shorter cooking time.
- If the cake is too dark on top: the next time put the cake on a lower shelf, cook it at a lower temperature and longer.
- If the top of the cake is burnt: cut off the burnt layer and cover with sugar or decorate it with cream, jam, confectioner's cream, etc..
- If the cake is too dark underneath: the next time place it on a higher shelf and cook it at a lower temperature.
- If the cake or bread is cooked nicely outside but is still uncooked inside: the next time use less liquids, cook at a lower temperature and longer.
- If the cake will not come out of the tin: slide a knife around the edges, place a damp cloth over the cake and turn the tin upside down. The next time grease the tin well and sprinkle it with flour or bread crumbs.
- If the biscuits will not come away from the baking tray: put the tray back in the oven for a while and lift the biscuits up before they cool. The next time use a sheet of baking parchment to prevent this happening again.

### Meat:

- If, when cooking meat, the time needed is more than 40 minutes, turn the oven off 10 minutes before the end of cooking time to exploit the residual heat (energy saving).
- Your roast will be juicier if cooked in a closed pan; it will be crispier if cooked without a lid.
- Normally white meat, poultry and fish need medium temperatures (less than 200°C).
- To cook "rare" red meats, high temperatures (over 200°C) and short cooking times are needed.
- For a tasty roast, lard and spice the meat.
- If your roast is tough: the next time leave the meat to ripen longer.
- If your roast is too dark on top or underneath: the next time put it on a higher or lower shelf, lower the temperature and cook longer.
- Your roast is underdone? Cut it in slices, arrange the slices on a baking tray with the gravy and finish cooking it.

### Grilling:

- Sparingly grease and flavour the food before grilling it.
- Always use the grill pan to catch the juices that drip from the meat during grilling (see fig. 11 or 12).
- Always put a little water in the drip pan. The water prevents the grease from burning and from giving off bad smells and smoke. Add more water during cooking because it evaporates.
- Turn the food half way through cooking.
- If you are grilling fatty poultry (goose) pierce the skin under the wings after about half an hour so the fat can drip away.

The aluminium can be easily corroded if it comes into contact with organic acids present in the foods or added during baking (vinegar, lemon juice). Therefore it is advised not to put directly the foods on aluminium or enamelled trays, but ALWAYS use the proper oven paper.

# INSTRUCTIONS FOR THE USER

## COOKING / BAKING TIMETABLE

FOODS	Weight kg	Position of the oven shelf from the bottom			COOKING BY NATURAL CONVECTION		COOKING BY FORCED CONVECTION (WITH FAN)	
		with 5 runners	with 4 runners	with 3 runners	Temperature in °C	Cooking Time in minutes	Temperature in °C	Cooking Time in minutes
<b>MEAT</b>								
Roast veal	1	1-2	1-2	2	200-225	100-120	190	100-120
Roast beef	1	1-2	1-2	1	200-225	40-50	190	40-50
Roast pork	1	1-2	1-2	2	200-225	100-120	190	100-120
Roast lamb	1	1-2	1-2	1	200-225	100-120	190	100-120
<b>GAME</b>								
Roast hare	1	1-2	1-2	2	200-Max	50-60	200-Max	50
Roast pheasant	1	1-2	1-2	2	200-Max	60-70	200-Max	60
Roast partridge	1	1-2	1-2	2	200-Max	50-60	200-Max	50
<b>POULTRY</b>								
Roast chicken	1	1-2	1-2	2	200-225	80-90	190	70-80
Roast turkey	1	1-2	1-2	2	200-225	100-120	190	90-110
Roast duck	1	1-2	1-2	2	200-225	90-110	190	80-100
<b>FISH</b>								
Roast fish	1	2-3	2	1	200	30-35	170-190	25-30
Casserole fish	1	2-3	2	1	175	20-25	160-170	15-20
<b>BAKED PASTA</b>								
Lasagne	2,5	3	2	1	210-225	60-75	225-Max	30-40
Cannelloni	2,5	3	2	1	210-225	60-75	225-Max	30-40
<b>PIZZA</b>	1	3	2	1	225-Max	25-30	225-Max	20-25
<b>BREAD</b>	1	3	2	1	225-Max	20-25	220	20
<b>PASTRIES</b>								
Biscuits in general		2	2	1	190	15	170-190	15
Shortcrust pastry		2	2	1	200	20	190-200	20
Victoria sponge	0,8	2	2	1	200	40-45	190-200	40-45
<b>CAKES</b>								
Angel cake	0,8	2	2	2	190	52	170-190	45
Fruit cake	0,8	2	2	2	200	65	190-200	65
Chocolate cake	0,8	2	2	2	200	45	190-200	45

The values given in the tables (temperatures and cooking times) are approximate and may vary according to each person's cooking habits. This table gives cooking times on only one shelf. If you are cooking with a fan oven and you are using more than one shelf (placing the shelves on the 2nd and 4th position or on the 1st and and 3rd position) cooking time will be about 5 to 10 minutes longer.

## GRILLING TIMETABLE

FOODS	Weight kg	Position of the oven shelf from the bottom			COOKING BY NATURAL CONVECTION		COOKING BY FORCED CONVECTION (WITH FAN)			
		with 5 runners	with 4 runners	with 3 runners	Temperature in °C	Cooking Time in minutes		Temperature in °C	Cooking Time in minutes	
						1 <sup>st</sup> side	2 <sup>nd</sup> side		1 <sup>st</sup> side	2 <sup>nd</sup> side
<b>MEAT</b>										
Chop	0,50	3	3	2	225-Max	12-15	12-15	200	15	10
Beefsteaks	0,15	3-4	3	1-2	200-225	5	5	=	=	=
Half chicken (each half 0.5 kg)	1	3-4	2-3	1-2	225	20	20	=	=	=
<b>FISH</b>										
Trout	0,42	4	3	2-3	225-Max	=	=	200	10	10
Sole	0,20	4	3	2-3	225-Max	=	=	200	7	7
<b>BREAD</b>										
Toast		4-5	3-4	3	225-Max	2-3	2-3	200	2-3	2-3
<b>SPIT (*)</b>										
<b>CHICKEN</b>	1,3	3	2	2	225-Max	60-80		=	=	

(\*) only certain versions

The values given in the tables (temperatures and cooking times) are approximate and may vary according to each person's cooking habits. In particular, temperatures and times for grilling meat will greatly depend on the thickness of the meat and on personal tastes.

# INSTRUCTIONS FOR THE USER

## CLEANING AND MAINTENANCE

- **Prior to any maintenance work or cleaning, disconnect the appliance from the electricity mains.**
- **Do not use a steam cleaner to clean this appliance.**
- **Do not wash the parts if they are still hot.**
- **Do not use metal pads, abrasive powders or corrosive spray products for cleaning**
- **Do not leave vinegar, coffee, milk, salty water or the juice of lemon or tomato on enamelled surfaces for any length of time.**
- **Switch off the oven before removing the fan guard for cleaning. Replace the guard after cleaning.**

### HOT PLATE

The enamelled steel pan supports, enamelled burner caps and burner heads need to be cleaned after each time they are used with warm soapy water, rinsed and then dried well to keep them in good condition.

#### WARNINGS:

- After cleaning, check that the heads burners and the relative burner caps, are correctly positioned in their housings (fig. 13).
- Take care not to disturb the ignition spark plugs or flame failure devices.
- If you find a tap is difficult to open or close do not force it but call for technical assistance urgently.
- After use, to keep them in good condition, the hot plates should be treated with specific products, easily found in the shops, to keep the surfaces clean and shining. This will also prevent rust from forming.
- If any liquid spills over it must always be removed with a sponge.

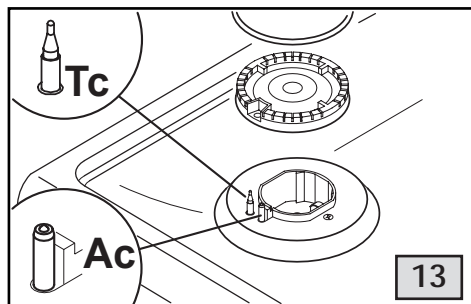

### CERAMIC GLASS HOB

It is very important to clean the top each time it is used and while the glass is still warm, drying it with a soft cloth. Do not use metal pads, abrasive powders or corrosive spray products for cleaning.

Depending on the degree of dirt, we recommend:

- For slight stains a damp sponge is enough
- The scraper must be used for more stubborn dirt (fig. 14). Use it carefully because it is easy to cut yourself. To avoid any such possibility, scrape away immediately from the cooking zone any tin foil sheets or plastic objects that could have melted or stuck, likewise sugar or sugary food spilled over during cooking.
- Remove any traces of spilled liquid with vinegar or lemon. Immediately remove any vinegar or lemon from the enamelled outer edge otherwise it will become opaque.
- Over time it is possible that colourings, metal reflections or scratches appear (fig. 15) caused by inefficient cleaning or by the incorrect movement of the pans. These scratches are difficult to eliminate but they will not prejudice how your hob works.

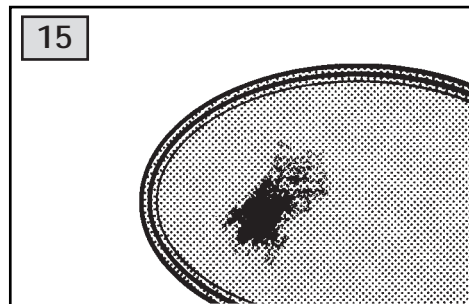
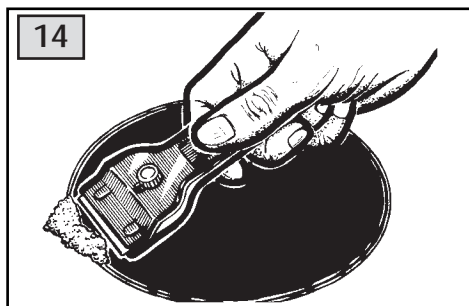

### 3. INSTRUCTIONS FOR THE USER

#### STRUCTURE

All the cooker parts (in enamelled or painted metal, steel, or glass) should be cleaned frequently with warm soapy water and then rinsed and dried with a soft cloth.

DO NOT use rough or abrasive materials or sharp metal scrapers to clean the oven glass doors as they could scratch and cause the glass to break

NEVER use sponges or abrasive products, and aromatic or aliphatic solvents to remove stains or adhesives on the painted or stainless steel surfaces.

#### OVEN CAVITY

Do not spray or wash the thermostat bulb with acid based products (check the product label before use). The manufacturer cannot be held liable for any damage caused by incorrect cleaning.

The oven cavity should be cleaned after each use to remove cooking residuals and or grease or sugar which, if burnt on when the oven is used again, will form deposits or unremovable stains as well as unpleasant smells.

To maintain the shine of the enamelled parts, clean them with warm soapy water, rinse and dry them thoroughly. ALWAYS wash the accessories used.

#### OVEN SEAL

The oven seal guarantees the correct functioning of the oven. We recommend you:

- clean it, avoiding abrasive tools or products.
- check its state now and then.

If the oven door seal has become hard or is damaged, contact our Service Centre and avoid using the oven until it has been repaired.

#### OVEN SIDE-GUIDE RAILS (fig. 16 )

For an effective cleaning of the oven side-guide rails, these can be extracted unscrewing knurled nuts (G). To fit the rails back in their place, first insert rear pins in holes and then secure them with the knurled nuts (G).

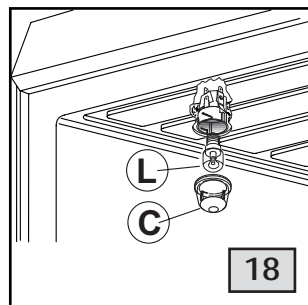
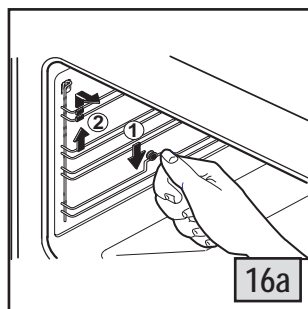
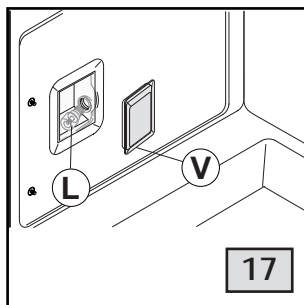
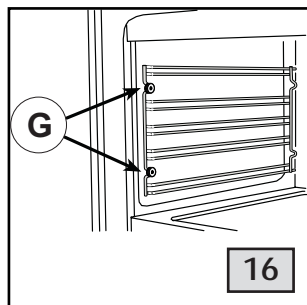

or (fig.16a)

1. Push with a finger on the last of the slots to release the grid from its hold.
  2. Lift it towards the top and extract the grid.
- To put them back into place, reverse the order of this operation.

#### REPLACING THE OVEN LAMP

Ensure the appliance is switched off before replacing the lamp to avoid the possibility of electric shock..

In the event one or both oven lamps need replacing, the new lamps must comply with the following requisites: 15 W - 230 V~ - 50 Hz - E 14 - and must be resistant to high temperature (300°C).

The appliance can have two different types of lamp holder:

- **Lamp holder type 1 (fig. 17):** Draw out the side guide rails as described above. Then, remove the glass protection cap (V) from the bulb socket, lifting it with a screwdriver placed between the cap and the oven wall and replace the lamp (L). Fit the accessories back in reverse order.
- **Lamp holder type 2 (fig. 18):** Turn glass protection cap (C) counterclockwise and change the lamp. Re-fit the cap, screwing it back in a clockwise direction.

## INSTRUCTIONS FOR THE USER

### OVEN DOOR REMOVAL

The oven door can be removed to give easier access to the oven when cleaning.

To remove, proceed as follows:

#### Hinges type 1

- Open the oven door and move the release U-shape element (fig. A) forwards until it is over the tooth in the upper sector of the hinge (fig. B).
- Partially close the door and at the same time, force the door upwards to release the lower sector of the hinge (fig. C) then pull the door and at the same time, slightly raise the door upwards to release the upper sector of the hinge (fig. D).
- To reassemble proceed in reverse order. Ensure you insert the upper sector of the hinge in its housing first and then the lower sector of the hinge.

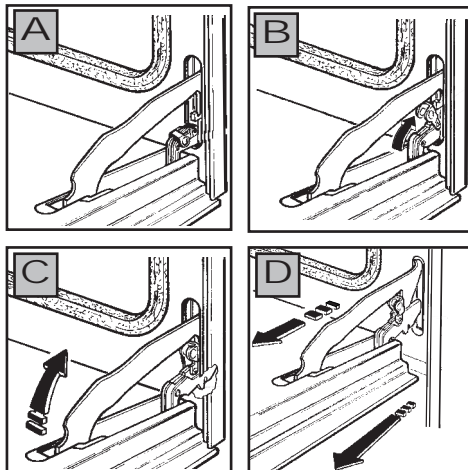

**ATTENTION!!** After cleaning the oven and before you close the oven door, ensure the release U-shaped elements are **COMPLETELY LOWERED** as indicated in fig. A

#### Hinges type 2

- Open the oven door and insert rivet or nail (R) in the hole (F) of the hinge (fig. G).
- Partially close the door, forcing it upwards at the same time to free stop tooth and hinge sector.
- Once the hinge is free, pull the door forwards tilting it slightly upwards to free sector.
- To reassemble proceed in the reverse order, paying attention to the correct position of sectors.

### HOW TO CLEAN THE INNER OVEN DOOR GLASS (only certain versions)

One of the features of our cookers is that the inner oven door glass can be easily removed for cleaning without the aid of specialized personnel. Just open the oven door and remove the support securing the glass (fig. E).

**ATTENTION!!** This operation can be done also with the door fitted on appliance, but in this way, pay attention that when the glass is pull upwards, the force of the hinges can close the door roughly.

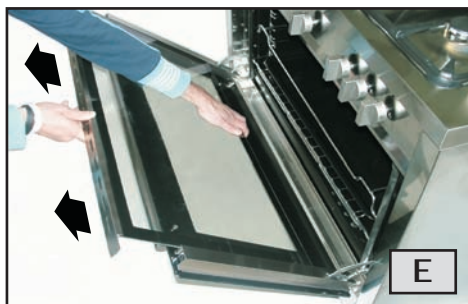
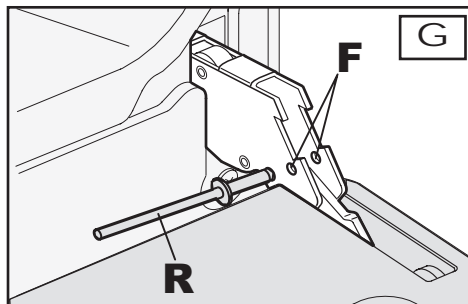

## TROUBLESHOOTING

Some of the problems occur because of simple maintenance oversights or operation mistakes and can easily be resolved without having to call for technical assistance.

PROBLEM	REMEDY
The appliance is not working	<ul style="list-style-type: none"> <li>• Make sure the gas cock is open</li> <li>• Check the plug is in</li> <li>• Check that the knobs are set correctly for cooking and then repeat the operations given in the handbook</li> <li>• Check the electrical system safety switches (RCD). If there is failure in the system call an electrician in.</li> </ul>
During use of the ceramic glass hob, the residual heat warning light does not switch on	<ul style="list-style-type: none"> <li>• Turn the knob round to a hotter temperature</li> <li>• Turn the knob of another element</li> <li>• Call our Assistance Centre</li> </ul>
The electric oven is not working	<ul style="list-style-type: none"> <li>• Check that the programmer accessory, if there is one, is on the manual position and then repeat the operations described in the manual</li> </ul>
The thermostat is not working	<ul style="list-style-type: none"> <li>• Call our Service Centre</li> </ul>
The electric thermostat warning light does not switch on during use	<ul style="list-style-type: none"> <li>• Turn the thermostat round to a hotter temperature</li> <li>• Turn the selector round to a different function</li> </ul>
The oven light does not switch on	<ul style="list-style-type: none"> <li>• Make sure the lamp is firmly screwed in place</li> <li>• Buy a lamp for high temperatures at one of our Service Centre and fit it following the instructions given in the REPLACING THE OVEN LAMP paragraph.</li> </ul>

**Warning: Servicing should be carried out only by authorised personnel.**

## TECHNICAL FEATURES

### OUTSIDE COOKER DIMENSIONS

TYPE COOKER	height H mm	height h mm	width L mm	depth P mm
60 x 60	1442	850	600	600
80 x 50	1340 ÷ 1345	850 ÷ 855	800	500
80 x 60	1440 ÷ 1455	850 ÷ 865	900	600
90 x 60	1440 ÷ 1455	850 ÷ 865	900	600
	917 ÷ 972	857 ÷ 912	900	600
100 x 60	1440 ÷ 1475	850 ÷ 885	1000	600
	1475 ÷ 1530	885 ÷ 940	1000	600

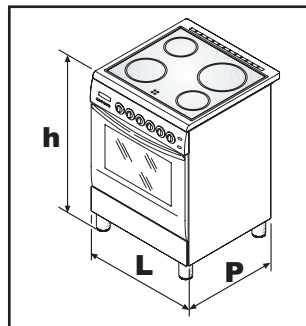
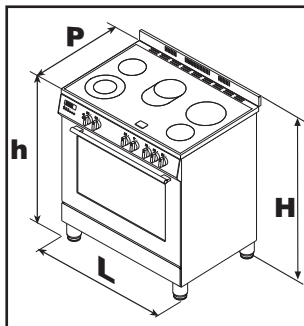
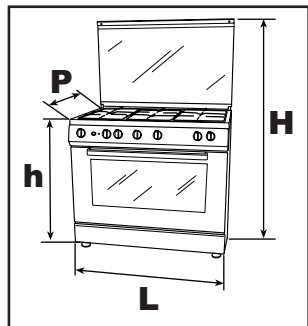



# TECHNICAL FEATURES

## BURNER AND ELECTRIC PLATE DISPOSITION

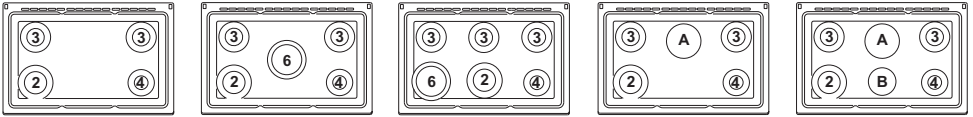

BURNERS		OPERATING PRESSURE GAS		DIAMETER INJECTOR	HEAT INPUT		AIR REG. SLEEVE OPENING	BY-PASS
N.	DENOMINATION	mbar		1/100 mm	Min	Max	"X" mm	1/100 mm
2	Rapid cooker 80 x 50	LPG - Butane	28-30	80	800	2500	=	44
		LPG - Propane	37	80	800	2500		
		Natural	20	110-Y	750	2500		
2	Rapid cooker 80 x 60 / 90 x 60 / 100 x 60	LPG - Butane	28-30	88	800	3000	=	44
		LPG - Propane	37	88	800	3000		
		Natural	20	117-Y	800	3000		
3	Semi-rapide	LPG - Butane	28-30	68	600	1800	=	34
		LPG - Propane	37	68	600	1800		
		Natural	20	98-Z	600	1800		
4	Auxiliary	LPG - Butane	28-30	51	400	1000	=	28
		LPG - Propane	37	51	400	1000		
		Natural	20	75-X	400	1000		
4	Auxiliary «mini»	LPG - Butane	28-30	45	400	800	=	28
		LPG - Propane	37	45	400	800		
		Natural	20	68-S	400	800		
6	Ultrarapid left front	LPG - Butane	28-30	92	1350	3250	=	62
		LPG - Propane	37	92	1350	3250		
		Natural	20	124-Y	1350	3250		
6	Ultrarapid central	LPG - Butane	28-30	98	1600	3800	=	62
		LPG - Propane	37	98	1600	3800		
		Natural	20	135-K	1600	3800		
7	Oven cooker 80 x 50 - 80 x 60 / 90 x 60 P	LPG - Butane	28-30	94	1000	3900	3	52
		LPG - Propane	37	94	1000	3900	3	
		Natural	20	142	1000	3900	2.5	
8	Grill cooker 80 x 50 - 80 x 60 -90 x 60 P	LPG - Butane	28-30	86	=	3050	3.5	=
		LPG - Propane	37	86	=	3050	3.5	
		Natural	20	131	=	3200	1.5	
8	Grill cooker 80 x 50 - 80 x 60 - 90 x 60 P door closed	LPG - Butane	28-30	70	=	2150	3.5	=
		LPG - Propane	37	70	=	2150	3.5	
		Natural	20	105	=	2150	1.5	
7	Oven cooker 90 x 60 Z - 100 x 60	LPG - Butane	28-30	108	1200	4800	3.5	55
		LPG - Propane	37	108	1200	4800	3.5	
		Natural	20	161	1200	4800	2.5	
8	Grill cooker 90 x 60 / 100 x 60	LPG - Butane	28-30	105	=	4500	3.5	=
		LPG - Propane	37	105	=	4500	3.5	
		Natural	20	161	=	4700	1.5	
8	Grill cooker 90 x 60 - 100 x 60 door closed	LPG - Butane	28-30	83	=	3000	3.5	=
		LPG - Pr	37	83	=	3000	3.5	
		Natural	20	131	=	3000	1.5	

# TECHNICAL FEATURES

## ELECTRIC COMPONENTS

Ref.	Description	Ø in mm	Nominal data
A	Fast heating plate	180	2000 W
B	Fast heating plate	145	1500 W
1	Hi-light radiant heating element	140	1200W
2	Hi-light radiant heating elementt	180	1700W
E	Hi-light radiant heating element	140	1200 W
F	Hi-light radiant heating element	210	2200 W
C	Hi-light double radiant heating element	120/210	700 + 1400 W
D	Hi-light double oval radiant heating element	170/265	800 + 1400 W
type cooker 60x60	Lower heating element of the oven cooker Top heating element of the oven-grill cooker Rear heating element type cooker		1400 W 1800+800W 2000 W
	Lower heating element of the oven cooker Top heating element of the oven-grill cooker Rear heating element type cooker Grill heating element type cooker 80 x 60/ 90 x 60 P Grill heating element type cooker 90 x 60 Z/ 100 x 60 Oven lamp Rear fan Spit motor		2100 W 2000 + 2200 W 3000 W 2200 W 2000 W 15 W - E 14 - T 300 25.29 W 4 W

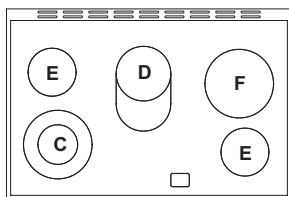
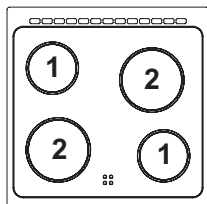

Cooker type	Cable type	Single-phase power 230 V ac	Three-phase power 230 V ac 3	Double-phase power 400 V ac 2N	Three-phase power 400 V ac 3N
		cross-section	cross-section	cross-section	cross-section
All-gas cooker	H05 RR-F	3 x 0.75 mm <sup>2</sup>	=	=	=
Combi cooker up to 2000 W	H05 RR-F	3 x 1 mm <sup>2</sup>	=	=	=
Combi cooker from 2000 to 3500 W	H05 RR-F	3 x 1.5 mm <sup>2</sup>	=	=	=
Combi cooker from 3500 to 5700 W (*)	H05 RR-F 13mm<Ø<14mm	3 x 2.5 mm <sup>2</sup>	4 x 2,5 mm <sup>2</sup>	4 x 2,5 mm <sup>2</sup>	5 x 1,5 mm <sup>2</sup>
Combi cooker from 5800 to 6700 W (*)	H05 RR-F 13mm<Ø<14mm	3 x 4 mm <sup>2</sup>	4 x 2,5 mm <sup>2</sup>	4 x 2,5 mm <sup>2</sup>	5 x 2,5 mm <sup>2</sup>
Electric cooker (*)	H05 RR-F 13mm<Ø<14mm	3 x 6 mm <sup>2</sup>	4 x 4 mm <sup>2</sup>	4 x 4 mm <sup>2</sup>	5 x 2,5 mm <sup>2</sup>

(\*) Taking into account the contemporaneity factor.

# INSTRUCTIONS FOR THE INSTALLER

## TECHNICAL INFORMATION

- The installation, adjustments, conversions and maintenance operations listed in this part must only be carried out by qualified personnel. The manufacturer cannot be held responsible for any damage to persons or property resulting from an incorrect installation of the appliance.
- The safety and automatic adjustment devices of the appliances may, during its life, only be modified by the manufacturer or duly authorised supplier.
- In accordance with the gas standard, the all-gas and combi appliances are "class 2 subclass 1" (recessed) and, as such, must comply with the clearances specified in fig. 17 and consequently any side walls must be no higher than the work top.
- The walls adjacent to and surrounding the appliances must be able to withstand an temperature of 95°C.
- The installation of all-gas and combi appliances must comply with the standards in force.
- This appliance is not connected to a flue for discharge of the combustion products; therefore, it must be connected in compliance with the above mentioned installation rules. Particular attention must be paid to the instructions given below for ventilation and aeration.

## INSTALLATION

### UNPACKING YOUR COOKER

- Once the wrapping has been removed from the outer surfaces and the various inner parts, thoroughly check that the appliance is in perfect condition. If you have any doubts do not use the appliance and call in a qualified person.
- Some parts mounted on the appliance are protected by a plastic film. This protection must be removed before using the appliance. We recommend slitting the plastic film along the edges with a sharp knife or pin.
- Do not move the appliance by the handle.

The packaging materials used (cardboard, bags, polystyrene foam, nails etc.) must not be left anywhere within easy reach of children as they are a potential hazard source.

### VENTILATION

The appliance should not be installed in a room of volume less than 20 m<sup>3</sup>.

The quantity of air necessary is that required for a

regular combustion of the gas and for the ventilation of the room. The natural flow of air must be direct through permanent openings in the walls of the room that open directly to the outside with a minimum cross section of 100 cm<sup>2</sup> (fig. 20). These openings must be positioned so they cannot be obstructed.

Indirect ventilation is also allowed by taking air from adjacent rooms to the one to be ventilated, strictly complying with the prescriptions of the standards in force.

### LOCATION AND AERATION

Gas cookers must always discharge the products of combustion and the moisture through hoods connected to flues or directly to the outside (fig. 21). If it is impossible to use a hood, a fan installed on the window or wall, facing the outside, is allowed and should be switched on each time the appliance is used (fig. 22) provided the rules and regulations in force relating to ventilation.

### POSITIONING THE COOKER

The appliances are fitted with the following parts to enable them to be correctly positioned:

- Spacers, positioned behind the rear panel to keep the appliance at the minimum required distance from the back wall. These must not be removed.
- Backguard. The cookers which are equipped with this accessory, leave of the factory with this particular inserted inside the packing. In order to install the backguard, it is necessary to loosen the screws positioned on the back of the hob and then to fix the backguard as indicated in figure 12.
- **Adjustable feet - type 1 (fig. 24)**, to be fitted to the appliance, which allow the height of the cooker to be aligned with other kitchen furniture. This can be done by means of the terminal part of the leg themselves
- **Adjustable feet - type 2 (fig. 24)**, to be fitted to the appliance, which allow the height of the cooker to be aligned with other kitchen furniture. A kit made of skirts, screws and feet is supplied to install on cooker. N.B.: The Allen wrench is not supplied.

# INSTRUCTIONS FOR THE INSTALLER

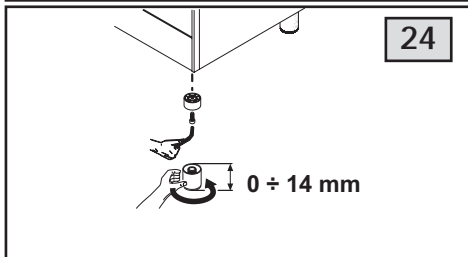
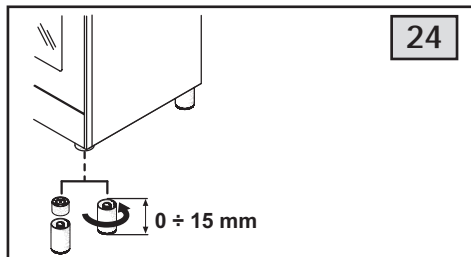
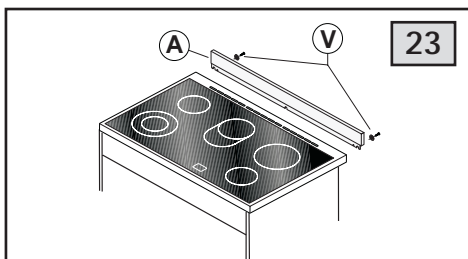
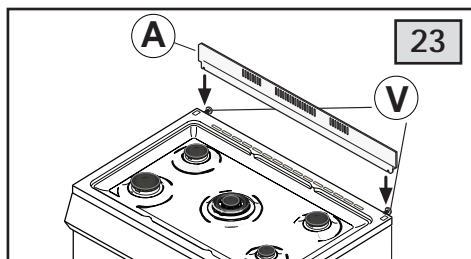
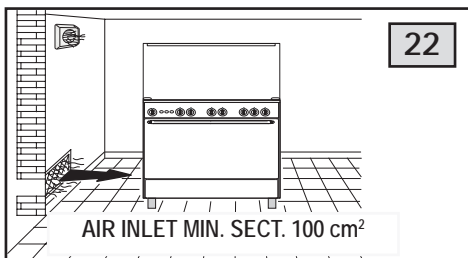
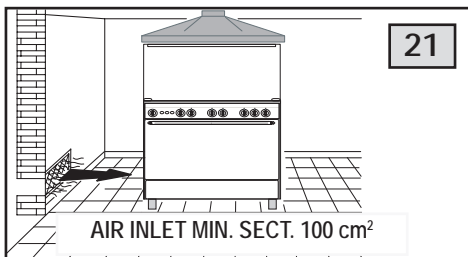
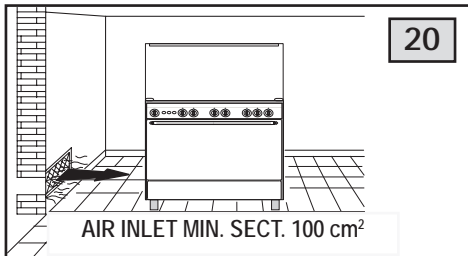
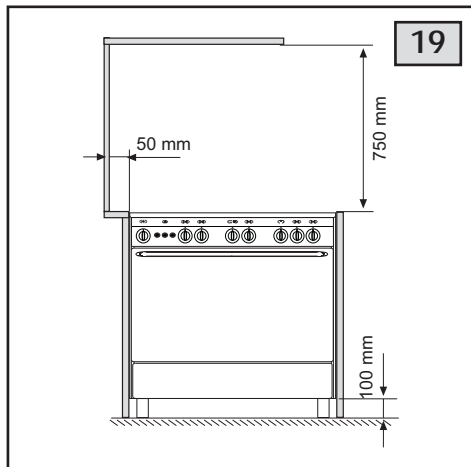

# INSTRUCTIONS FOR THE INSTALLER

## GAS CONNECTION

Before connecting the appliance check that the **data on the rating plate affixed to the cooker**, correspond to those of the gas mains.

A label on the back of this handbook and at the back of the cooker gives the appliance adjustment conditions, that is, the type of gas and operating pressure.

Once the cooker is installed, check there are no **leaks using a soapy solution (never a flame)**.

The appliance's gas inlet fitting is a threaded 1/2" male cylindrical type, in compliance with the ISO 228-1 standards. If gas is distributed through ducts the appliance must be connected to the gas mains with:

- a rigid steel pipe, in accordance with standards, whose joints must be made using threaded fittings in accordance with the UNI-ISO 7/1 standard. The use of hemp with suitable adhesives or Teflon tape as a sealant is allowed.
- copper pipe, in accordance with the standard, whose joints must be made using sealed fittings in accordance with the standard.
- a flexible stainless steel, seamless pipe in accordance with the standard, with a maximum 2 metre extension and seals in accordance with the standard.
- a flexible rubber hose in accordance with the standard, with an 8 mm diameter for LPG and 13 mm for natural gas or town gas, maximum 1500 mm in length, firmly secured to the hose fitting with a safety clamp as per the standard.

If the gas is supplied directly from a gas cylinder, the appliance, fed by a pressure regulator in accordance with the standard, must be connected:

- with a copper pipe in accordance with the standard, whose joints must be made using sealed fittings in accordance with the standard.
- with a flexible stainless steel, seamless pipe in accordance with the standard, with a maximum 2 metre extension and seals in accordance with the standard. We recommend applying the special adapter to the flexible pipe, easily found on the market, to facilitate connection to the pressure regulator's hose fitting on the cylinder.
- with a flexible rubber hose in accordance with the standard, with an 8 mm diameter, minimum 400 mm in length, maximum 1500 mm in length, firmly secured to the hose fitting with a safety clamp as per the standard.

## ATTENTION:

- **If the appliance is going to be recessed (class 2 subclass 1)**, connect it to the gas supply source using **only flexible stainless steel, seamless pipes** in accordance with the standard.
- **If the appliance is going to be installed free-standing (class 1) and if you use the flexible rubber hose**, it is necessary to follow the instructions given below:
  - **On its route, the hose must not touch any parts** where the over temperature is more than 95°C.
  - **The hose must not be subject to any kind of torsional stress or tractive force**, there must be no pinched parts or really sharp bends.
  - **It must not touch anything that can cut**, that has sharp corners, etc.
  - **The whole length of the hose must be easy to inspect** in order to keep a check on its condition.
  - **It must be replaced within the date printed on it.**

# INSTRUCTIONS FOR THE INSTALLER

## ELECTRICAL CONNECTION

The electrical connection must be carried out in accordance with the current standards and laws in force.

Before connecting check that:

- The system and electrical sockets amperage is adequate for the appliance maximum power (see data label affixed on the back of the cooker).
- The socket or system has an effective earth connection in accordance with current standards and prescriptions of the law. All responsibility is disclaimed if this is not complied with.
- The plug and socket or the multipolar switch must be accessible after installation of the appliance.
- If the appliance has no power cable, connect one with a suitable cross section to the terminal board (see paragraph «CONNECTING THE POWER CABLE»).

When connecting to the mains with a socket:

- Fit to the power cable (if without) a standardized plug, suitable for the load which is indicated on the data label. Connect the wires making sure they correspond as shown below, and remember that the earth wire must be longer than the phase wires:

letter L (phase) = brown wire  
 letter N (neutral) = blue wire  
 symbol  (earth) = green/yellow wire

- The power cable must be laid so that no parts of it ever reach a temperature of 75 °C.
- For connecting do not use, adapters or shunts as they could cause false contacts resulting in hazardous overheating.

When connecting directly to the mains:

- Install a multipolar switch that can withstand the appliance load, with a minimum opening between the contacts of 3 mm.
- Remember that the earth wire must not be cut out by the switch.

## CONNECTING THE POWER CABLE

The all-electric cookers and some combi versions leave the factory ready for single-phase power, but they can, with due modifications, be powered by three phase systems by following these instructions:

- Remove the rear panel from the cooker.
- Move the connecting plates in the terminal board according to the type of connection you want, following the diagram in fig. 25. You will also find this diagram affixed to the back of the cooker.
- Connect the power cable, whose cross section must be suitable on «TECHNICAL FEATURES» paragraph, keeping the earth wire longer than the phase wires.
- Secure the cable in the clamp and - fit the rear panel in place.

25

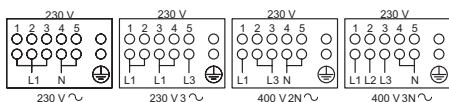

# INSTRUCTIONS FOR THE INSTALLER

## ADJUSTMENTS

- Always disconnect the appliance from the electricity supply before making any adjustment.
- All seal must be replaced by the technician following any adjustment or regulation.
- The adjustment of the reduce rate (simmer) must be undertaken only with burners functioning on natural gas while in the case of burners functioning on L.P.G, the screw must be locked down fully (in clockwise direction).
- “Primary air adjustment” on hob gas burners is unnecessary.

### TAPS

All gas taps are male cone type with only one way of passage. Adjustment of the “Reduced rate” position as follows:

- Turn the burner on and place the knob on the “Reduced rate” position (small flame).
- Remove the knob (A) of the tap which is attached by simply applying pressure to the rod.
- Insert a small screwdriver (C) into hole (F) (fig. 26a) and turn to the right or left the throttling cone until the flame of the burner is conveniently regulated to the Low position.
- In the case of taps with flame failure device, the adjustment screw (V) is on the side of the stem (fig. 26b).
- Check that the flame does not go out when the knob is sharply switched from the “Full on” to “Reduced rate” positions.
- **ATTENTION!!** This operation can be carried out also with the front panel fitted, but if the technician finds some difficulties to reach the adjustment screw, remove the front panel unscrewing the fixing screws (Vf) (fig. 31), which are positioned in the inferior part of the same.

### OVEN THERMOSTAT (fig. 27)

Reduced rate adjustment should be carried out in the following way:

- Remove the knob thermostat.
- Switch on the oven burner by turning the relative knob to the Maximum position, then wait about 10 minutes.
- Slowly turn the knob back to the Minimum position and, using a small screwdriver (C), turn screw (V) to the right to lower the flame or to the left to increase it. The flames must be short for an efficient Reduced rate setting. They must be stable to prevent them from accidentally going out and must be able to stand up to normal oven door manoeuvres.

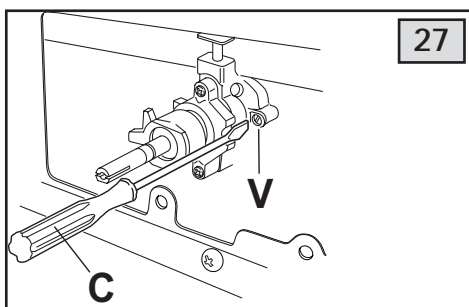
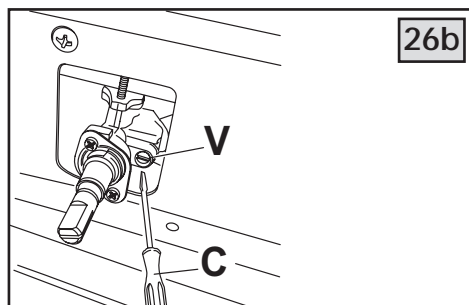
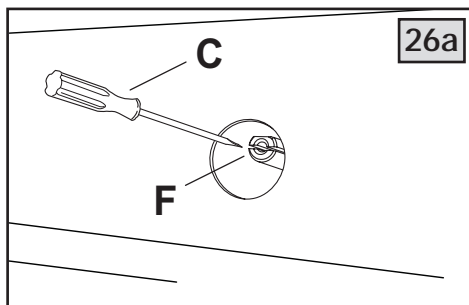

## INSTRUCTIONS FOR THE INSTALLER

### OVEN BURNER (fig. 28)

The burner is installed on the oven base and is covered by the bottom plate which must always remain in that position during oven operation,

To adjust the primary air, light the burner and, watching the flame, slacken screw (A) and adjust sleeve (B) to obtain the X openings indicated in the table on <TECHNICAL FEATURES> paragraph. Lock screw (A) in place once the adjustments have been made.

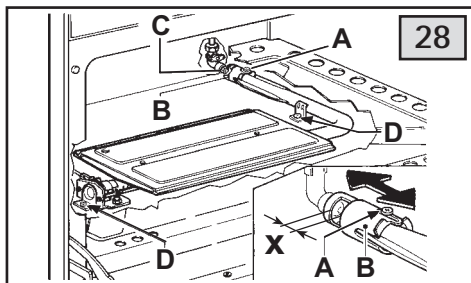

### GRILL BURNER (fig. 29)

To adjust the primary air, light the burner and, watching the flame, slacken screw (A) and adjust sleeve (B) to obtain the X openings indicated in the chart on <TECHNICAL FEATURES> paragraph. Lock screw (A) in place once the adjustments have been made.

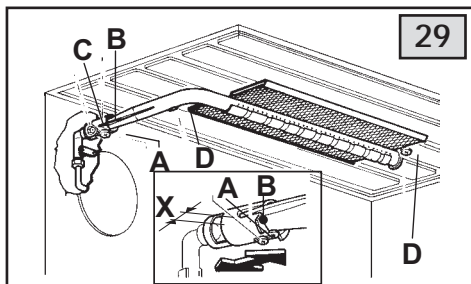

## CONVERSIONS

### REPLACING THE INJECTORS

Our burners can be adapted to different types of gas by simply installing the injectors suitable for the gas you want to use. To help the installer, the table on <TECHNICAL FEATURES> paragraph gives the burner nominal heat input, injector diameter and operating pressure of the different gas types.

Comply with the following instructions:

**Injector replacement - Hob burners.**

To change the injectors on the hob, remove the burner cup and head and with a 7 mm Ø socket spanner replace them (fig. 30).

**Injector replacement - Oven burner.**

Remove oven base. Remove screw (D) which will release burner and give access to the injector (C) (fig. 28). Unscrew injector and replace it. Replace burner and replace screw (D).

**Injector replacement - Grill burner.**

Remove screw (D) which will release burner and give access to the injector (fig. 29). Unscrew injector (C) and replace it. Replace burner and replace screw (D).

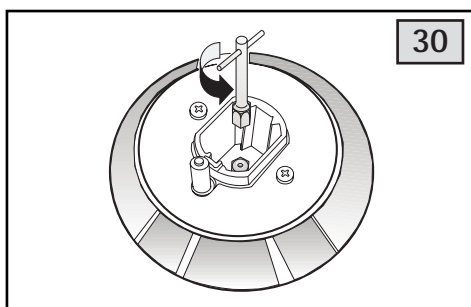

After having replaced the injectors, it will be necessary to proceed with burner adjustment as explained in the previous paragraphs. The technician must replace any seals after the adjustments have been made.



# INSTRUCTIONS FOR THE INSTALLER

## MAINTENANCE

Prior to any maintenance work or changing parts, disconnect the appliance from the gas and electricity power sources.

### REPLACING THE TAPS AND THERMOSTAT

Proceed in the following way when replacing a tap or the thermostat:

- Remove pan supports, burner heads.
- Unscrew the burner fixing screws (Vc) (fig. 31). (four for ultrarapid burner and two for the other burners)
- Pull out the knobs.
- Unscrew the three fixing screws (Vf) (fig. 31) which lock the front panel to the front frame then slip out from the upper fixing brackets.
- Unscrew the six fixing screws (Vp) (fig. 31) which lock the side profiles and remove it.
- Unscrew the two fixing screws (Vd) (fig. 31) which lock the hob at the back and remove it.
- Unscrew the nuts (D) of the gas aluminium pipes and pull out the thermocouple quick connectors (F) (fig.33).
- Unscrew the screws (Vt) (fig. 32) which lock the crosspieces.
- Unscrew the screws (Vb) (fig. 32) which unite the the bridles of the taps to the front frame.
- Make to slip the ramp toward the back part and unscrew the screws (Vb) (fig. 33) in order to free the taps.
- Change seal each time a tap or a thermostat is replaced. This will ensure perfect retention between the tap or a thermostat and part.
- Reassemble all the parts following the same procedure but in the reverse order.

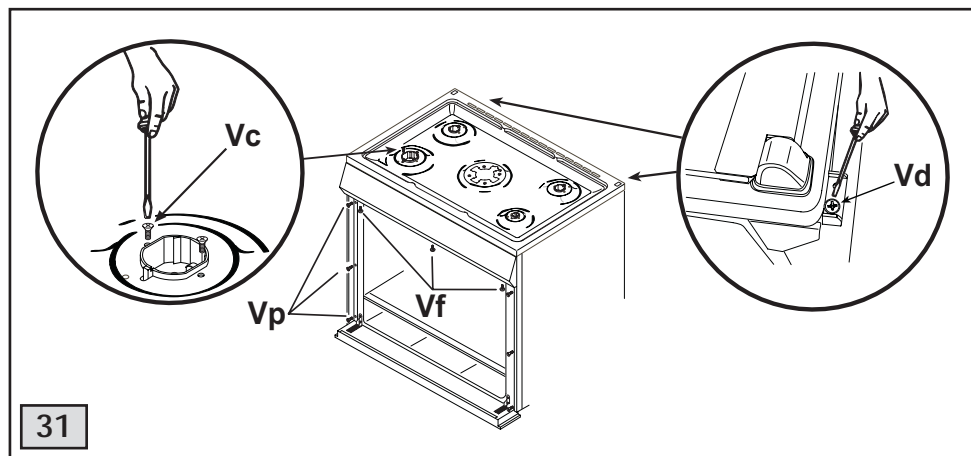
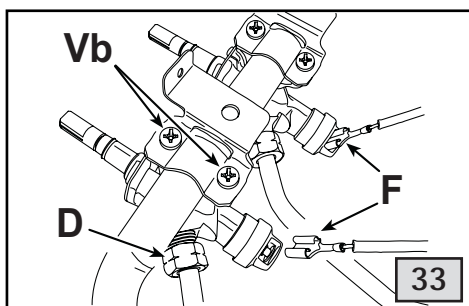
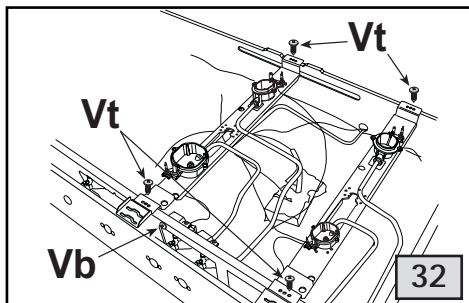

## INSTRUCTIONS FOR THE INSTALLER

### CHANGING THE FLEXIBLE GAS HOSE

In order to guarantee that the gas hose is always in excellent condition we strongly recommend changing it on the date you will find printed on it.

### REPLACING THE ELECTRICAL COMPONENTS

- The rear protection will have to be removed in order to change the electrical heating elements, spit motor, terminal board and power cable.
- If you have to change the power cable (see the cross section on table on page 27), always keep the earth wire longer than the phase wires and, in addition, follow all the instructions given in the «ELECTRICAL CONNECTION» paragraph.
- To change the oven lamp see the instructions on REPLACING THE OVEN LAMP paragraph.
- To change the lamp holder type 1 (fig. 15), remove the side panels and then use a screwdriver to push the two locking tabs (fig. 34) and remove the lamp holder from the inside of the oven.
- To change the lamp holder type 2, the spark generator and the spark electrodes, the work top has to be removed as indicated in paragraph «REPLACING THE TAPS AND THERMOSTAT».

- To change the lamp-holder type 2 (fig. 16), unscrew the protective glass cap (C), force the tabs of blockage and take the lamp-holder toward the inside of the oven.
- To change the eventual programming accessory, the thermostat, the commutator and the indicator lights, remove the front panel as indicated in paragraph «TAPS»
- To change the hob electrical heating elements, remove the hob, unscrewing frontal and rear fixing screws (Vs) (fig. 35) which lock the hob at the supports (S).

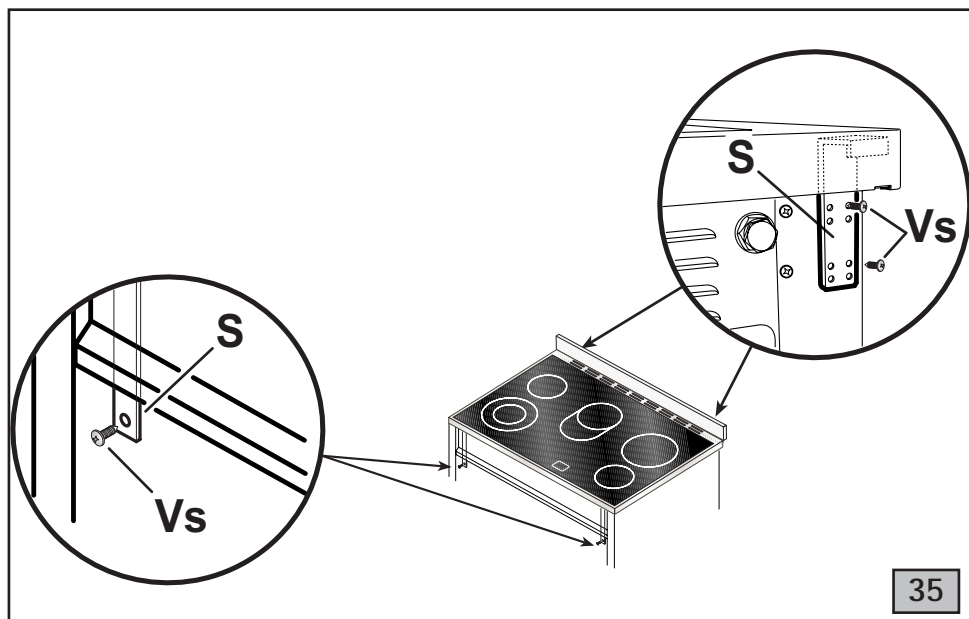
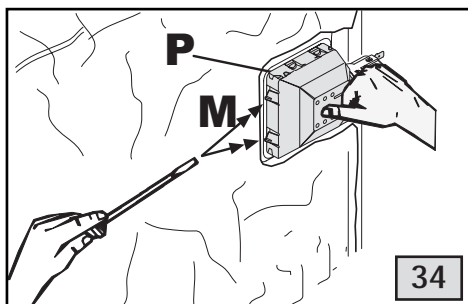

# INSTRUCTIONS FOR THE INSTALLER

## MAINTENANCE

Prior to any maintenance work or changing parts, disconnect the appliance from the gas and electricity power sources.

### REPLACING THE TAPS AND THERMOSTAT

Proceed in the following way when replacing a tap or the thermostat:

- Remove pan supports, burner heads.
- Unscrew the burner fixing screws (Vc) (fig. 36). (four for ultrarapid burner and two for the other burners)
- Remove the hob, unscrewing rear fixing screws (Vs) (fig. 36) which lock the hob at the supports (S).
- Pull out the knobs.
- Unscrew the three fixing screws (Vf) (fig. 36) which lock the front panel to the front frame then slip out from the upper fixing brackets.
- Unscrew the six fixing screws (Vp) (fig. 36) which lock the side profiles and remove it.
- Unscrew the two fixing screws (Vd) (fig. 36) which lock the hob at the back and remove it.
- Unscrew the nuts (D) of the gas aluminium pipes and pull out the thermocouple quick connectors (F) (fig.33).
- Unscrew the screws (Vt) (fig. 32) which lock the crosspieces.
- Unscrew the screws (Vb) (fig. 32) which unite the the bridles of the taps to the front frame.
- Make to slip the ramp toward the back part and unscrew the screws (Vb) (fig. 33) in order to free the taps.
- Change seal each time a tap or a thermostat is replaced. This will ensure perfect retention between the tap or a thermostat and part.
- Reassemble all the parts following the same procedure but in the reverse order.

