

Thank you for the confidence you have shown by buying this appliance. We hope it will successfully serve its purpose for many years.

The appliance is intended solely for household use.

This refrigerator is intended for domestic use only, for storing fresh food at temperatures higher than 0°C.

Before putting into use2
Instructions for use
Mounting instructions
We care for the environment
Energy savings tips

Important3
Disposing of the worn out appliance

Placing and installation.....5
Choosing the right place
Connection to power supply

Adjusting the height of the appliance

Description of the appliance5
Temperature selection

Use.....6
Storing fresh food

Maintenance and cleaning7
Automatic defrosting of the refrigerator
Cleaning the appliance
Switch off the appliance when not in use

i Before putting into use

- Before connecting the appliance to the power mains, leave it stand for about 2 hours. This will reduce the probability of malfunctions in the cooling system due to transport and handling.
- Clean the appliance thoroughly, especially the interior (see Cleaning and Maintenance).
- If the interior accessories are not correctly placed, rearrange them as described in the chapter Description of the Appliance.

Instructions for use

These instructions for use are intended for the user. They describe the appliance and its correct and safe use. As they were prepared for various types/models of refrigerators, you may find descriptions of functions and accessories that are not available in your appliance.

Mounting instructions

Integrated appliances are equipped with instructions for mounting the appliance into the kitchen unit.

The appliance should be professionally mounted by a qualified technician; mounting instructions are for his use only.

We care for the environment

- Our appliances are distributed in packaging made of environmentally friendly materials which can be safely recycled, disposed of or destroyed, with no effect on the nature whatsoever.
- These instructions are printed either on recycled paper or chlorine-free bleached paper.
- When your appliance finally wears out, please do not burden the environment with it; call your nearest authorized service agent (see Disposing of the worn out appliance).

Energy savings tips

- Do not open the door too often, especially when the weather is wet and hot. Once you open the door, close it as soon as possible. This is especially important if you have an upright model.

- Check periodically if adequate ventilation is allowed (undisturbed circulation of air through the bottom rail openings).

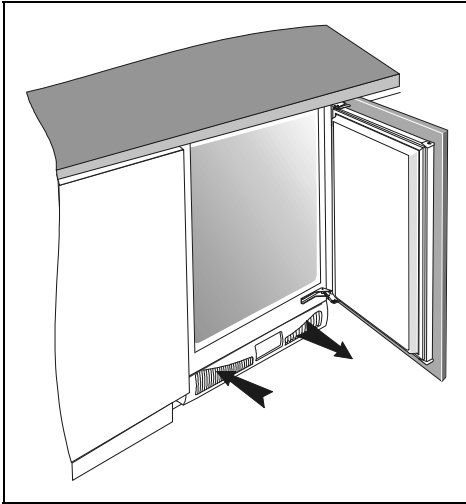

- Turn the thermostat knob from higher to lower setting as soon as possible

(depending on how loaded the appliance is, ambient temperature etc.).

- Before putting fresh food into the appliance, let the food cool down to room temperature.
- A layer of ice and frost will increase energy consumption. Therefore, clean the appliance as soon as the layer is 3-5 mm thick.
- If the gasket is damaged or if it does not provide a tight seal, the energy consumption will be substantially higher. To restore efficiency, replace the gasket.
- Condenser at the bottom of the appliance must always be clean and free of dust (see section **Cleaning of the Appliance**).
- Always comply with the instructions in sections Positioning and Energy Saving Tips; otherwise the energy consumption may be substantially higher.

⚠ Important

- The appliance is manufactured in compliance with the effective safety standards. However, it can be used by children aged from 8 years and above and persons with reduced physical, sensory or mental capabilities or lack of experience and knowledge if they have been given supervision or instruction concerning use of the appliance in a safe way and understand the hazards involved.
- If you bought this appliance to replace an old one that was equipped with a lock that cannot be opened from inside of the appliance (lock, bolt), make sure that the lock is broken. This will make it impossible for children to lock themselves inside the refrigerator and suffocate.
- The appliance must be correctly connected to the power mains (see: Connecting to the Power Mains).
- If the food has strange smell or colour, throw it away, because it is very likely that it is spoiled and therefore dangerous to eat.
- Disconnect the appliance from the power supply before repairing it (only a qualified technician should repair it), before cleaning and before replacing the light bulb.
- Do not defrost the appliance with other electric appliances (as for example with hair dryer) and never scrape the frost layer with sharp objects. Use only enclosed tools or tools recommended by the manufacturer.
- To protect the environment, be careful not to damage the rear wall of the appliance (the condenser unit or the tubes, for example when moving the appliance) or any part of the refrigeration system inside the appliance.
- The refrigeration system of the appliance is filled with refrigerant and oil. When the appliance is damaged, handle it with care and dispose it of in compliance with environment-protection regulations (see We Care for the Environment).
- If the supply cord is damaged, it must be replaced by the manufacturer, a service agent or other qualified person in order to avoid hazard.
- The rating plate is located inside the appliance or outside on the rear wall.

- **Warning!** Ventilation slots on the appliance or a built-in element must always be clean and unobstructed.
- **Warning!** Do not use mechanical devices or tools to defrost the refrigerator, nor any other methods except for those recommended by the manufacturer.
- **Warning!** When installing, cleaning, or removing the appliance, make sure the insulation on the refrigeration system parts is not damaged. Thus you will also prevent damage to the environment.
- **Warning!** Do not use electric appliances in the refrigerator or freezer interior, except for those expressly

allowed by the refrigerator-freezer manufacturer.

- After the installation, the appliance mains plug should be accessible!



The symbol on the product or on its packaging indicates that this product may not be treated as household waste. Instead it shall be handed over to the applicable collection point for the recycling of electrical and electronic equipment. By ensuring this product is disposed of correctly, you will help prevent potential negative consequences for the environment and human health, which could otherwise be caused by inappropriate waste handling of this product. For more detailed information about recycling of this product, please contact your local city office, your household waste disposal service or the shop where you purchased the product.

Disposing of the worn out appliance

- When your appliance finally wears out, dispose of it. If the appliance has a lock, break it to prevent any accidents (danger of children getting locked inside the appliance).
- The refrigeration system of the appliance is filled with refrigerant and insulating substances which should be treated and processed separately. Call your nearest authorized service agent or specialized servicing centre. If you cannot find one, contact your local authorities or your distributor. Be careful not to damage the tubes on the rear wall of the appliance (danger of pollution).
- To avoid pollution of the environment make sure not to damage the hose at the bottom of the appliance.

Placing and installation

Choosing the right place

Place the appliance in a dry and regularly ventilated room. Allowed ambient temperature depends on the model (class) of the appliance and it is stated on the rating plate of the appliance.

Never place the appliance near heat emitting devices (e.g. cooker, radiator, water heater or similar devices) and do not expose it to direct sunlight.

The appliance should be positioned at least 3 cm away from the electric or gas cooker and at least 30 cm away from the oil or coal stove. If this is not possible, use appropriate insulation.

Class	Ambient temperature
SN (subnormal)	from + 10°C to + 32°C
N (normal)	from + 16°C to + 32°C
ST (sub-tropical)	from + 16°C to + 38°C
T (tropical)	from + 16°C to + 43°C

Connection to power supply

Use the cable and plug to connect the appliance to the power supply socket with a ground terminal (safety socket).

Required nominal voltage and frequency are indicated on the rating plate.

The connections to the mains supply and earthing have to be made according to currently relevant standards and regulations.

The appliance resists temporary voltage fluctuations of up to +/- 6%.

Adjusting the height of the appliance

The appliance is equipped with four adjustable legs which allow adjusting the height from 82 to 90 cm. The height must be adjusted prior to building the appliance into the opening slot, and it should be set at such height that the top panel of the appliance fits exactly below the kitchen worktop (see **Mounting Instructions**).

Description of the appliance

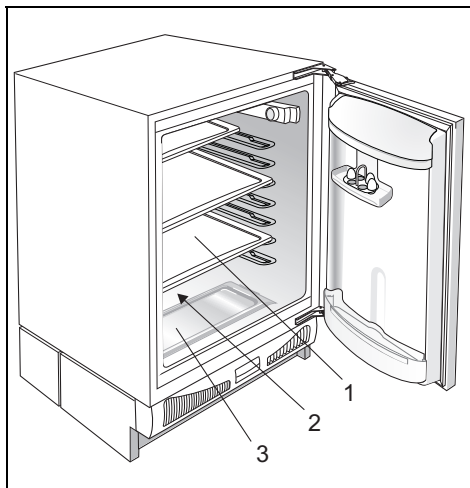

Shelf (1)

The shelf may be placed randomly on any of the guide slots in the interior of the appliance. It is protected against sliding out.

The shelf is placed on the top 4 guides by lowering the front edge of the shelf downwards, placing the rear of the shelf onto the guide slot and inserting the shelf in the guide in the inclined position.

The shelf is placed on the lower 3 guides by lifting the front part of the shelf upwards, placing the rear of the shelf onto the guide slot and inserting the shelf in the guide in the inclined position.

In case you wish to remove the shelf from the appliance lift the shelf by hand at the rear and pull it out by following the opposite procedure. Glass shelves are protected with plastic edge frames.

Quickly perishable food should be stored closer to the back wall, i.e. in the coldest part of the shelves.

Defrosting water outlet (2)

The interior of the refrigerator is cooled with a cooling plate incorporated in the rear wall. Under the plate there are a channel and an outlet for defrosting water.

Regularly check the defrosting water outlet and the channel because they should never be clogged (as for example with food residues). If clogged, use a plastic straw to clean it.

Crisp tray and serving tray (3)

The tray at the bottom of the refrigerator is covered with the serving tray. This cover protects the stored fruit and vegetables from excessive drying.

Door liner

The door liner consists of various shelves or holders used for storing eggs, cheese, butter and yogurt as well as other smaller packages, tubes, cans etc.

The lower shelf is used for storing bottles.

Illumination in the interior of the refrigerator

The light for illuminating the interior of the appliance is switched on when the door is opened. Operation of the light does not depend on the position of the thermostat knob.

Operation control

Appliance operation is controlled with the thermostat knob located in the upper right part inside the appliance.

Turn the knob from the **STOP (0)** position towards **7** and backwards.

Temperature selection

- Higher settings on the knob (towards **7**) mean lower temperatures (colder) in all three compartments of the appliance. Temperature in the interior of the appliance may even drop below 0°C. Higher settings should only be used when higher temperature is recommended or required.
- When the ambient temperature is normal, we recommend a medium setting.
- Changes of the ambient temperature affect the temperature in the interior of the

appliance (choose the correct setting of the thermostat knob).

- In the **STOP (0)** position the appliance does not operate (the cooling system is switched off), yet power supply is not cut off (the light is on when you open the refrigerator door).
- Temperature in the refrigerator also depends on how often the door is opened.

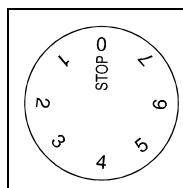

Use

Storing fresh food

Proper use of the appliance, adequately packed food, correct temperature and hygienic precautions will substantially affect the quality of the food stored.

- Foods to be stored in the refrigerator should be properly packed to prevent mixing various moisture degrees and odours (in polyethylene bags or sheet, aluminium foil, wax paper, or stored in covered containers or bottles).
- Before storing food in the refrigerator, remove excessive packaging (like cardboard in yoghurt multi-packs).

- Pack systematically and make sure that the items do not touch each other (various odours may mix). Allow for adequate air circulation around packages.
- Never store inflammable, volatile or explosive substances.
- Beverages with high alcohol content should be stored in tightly sealed bottles in upright position.
- Food should not touch the rear wall of the refrigerator!
- Food should be cooled down before storing.
- Crispy and delicate food should be stored in the coldest parts of the refrigerator.

- Try not to open the door too often.
- Set the thermostat to the lowest temperature setting. Set the thermostat gradually to avoid freezing of the food.
Use a thermometer to measure the temperature in the individual compartments. Place the thermometer in a glass vessel filled with water. Temperature readings are most reliable a few hours after a steady state is reached.
- Some organic solutions like volatile oils in lemon or orange peel, acid in butter etc. could cause damage; when in prolonged contact with plastic surfaces or gaskets they can even cause accelerated ageing of the plastic material.
- Unpleasant odour inside the refrigerator is a sign that something is wrong with the food or that your refrigerator needs cleaning. Unpleasant odour can be eliminated or reduced by washing the interior of the refrigerator with a mild solution of water and vinegar.
- We also recommend using activated carbon filters to clean the air or to neutralize the odours.
- If you plan a longer journey, make sure to remove quickly perishable articles of food from the appliance before you leave.

Fresh food storage time in the refrigerator

Type of food	Storage time (days)													
	1	2	3	4	5	6	7	8	9	10	11	12	13	14
Butter	+	+	+	+	+	+	+	=	=	=	=	=	=	=
Eggs	+	+	+	+	+	+	+	+	+	+	=	=	=	=
Meat: fresh uncut chopped smoked	+	+	=											
	+	=												
	+	+	+	+	+	+	+	+	+	+	=	=	=	=
Fish	+	=												
Marinade	+	+	+	+	+	+	+	+	+	+	=	=	=	=
Root	+	+	+	+	+	+	+	+	=	=	=	=	=	=
Cheese	+	+	+	+	=	=	=	=	=	=	=	=	=	=
Sweets	+	+	=	=	=	=								
Fruit	+	+	=	=	=	=	=	=	=	=				
Prepared dishes	+	+	=	=										

Legend: + recommended storage time = possible storage time

Maintenance and cleaning

Automatic defrosting of the refrigerator

The refrigerator requires no defrosting since the ice at the rear wall melts automatically. Ice formed at the rear during the operation of the compressor melts when the compressor is off and water drops slide downwards through the hole in the rear wall into the condensate receptacle placed at the bottom of the appliance.

Cleaning the appliance

Disconnect the power supply before cleaning the appliance.

Do not use coarse or aggressive cleaning agents as you may damage the surface. Be careful to remove any cleaner agent remaining after cleaning.

- Clean the **exterior** with water and detergent.
- Varnished surfaces are cleaned with a soft cloth and an alcohol-based cleaning agent (for example glass cleaners). You may also use alcohol (ethanol or isopropyl alcohol).
- The application of abrasive and especially aggressive cleaners such as stainless steel cleaners is not appropriate for cleaning of plastic and coated parts.
- Remove the **detachable accessories** in the interior of the appliance and clean them with

water and liquid detergent. Plastic parts cannot be washed in washing machine.

- Wash the **interior** of the appliance with lukewarm water to which you have added one or two spoonfuls of vinegar.
- **The air openings in the bottom rail** should be cleaned or vacuumed periodically.

Cleaning of the condenser

Dust from the condenser should be vacuumed in the following manner:

- push the finger through the opening in the bottom rail and release the fastener;
- pull the rail towards you and remove it;
- remove the bottom board of the kitchen cabinet;
- pull the condenser dish out;
- use the vacuum cleaner to clean the dust from the condenser;
- replace the condenser dish and the bottom rail in the opposite order.

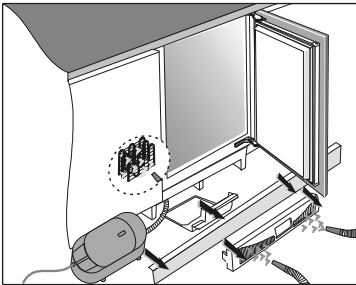

After cleaning, connect the appliance to power supply and reload it.

Periodical cleaning of the condenser

In order to optimize the operation of the appliance and save energy, it is recommended to periodically clean the dust from the condenser at the back of the appliance.

Disconnect the appliance from the power mains prior to the commencement of cleaning!

- Empty the contents of the appliance.
- Remove the supporting panel from the bottom of the kitchen cabinet.
- Remove the screws fixing the appliance to the kitchen worktop.
- Pull the appliance out to expose the condenser at the back of the appliance.
- Unscrew the screws from the condenser bonnet and remove the bonnet.
- Clean the dust and dirt from the condenser.

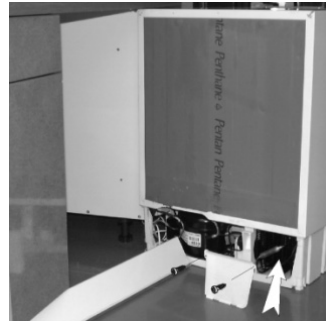

After cleaning return the appliance to its place, plug in the power mains cord and fill with food.

Switch off the appliance when not in use

If you do not intend to use the appliance for a longer period, set the thermostat knob to the **STOP (0)** position, disconnect the power supply, take out the food and defrost and clean the appliance. Leave the door slightly open.

? Troubleshooting guide

During the service, you can come across some problems that in most cases result from improper handling of the appliance and can easily be eliminated.

The appliance fails to operate after connecting to the mains supply

- Check the supply in the outlet socket and make sure the appliance is switched on (thermostat knob in operating position).

Continuous operation of the cooling system

- The door was frequently opened or it was left opened for too long.
- The door is not properly closed (the door may sag; the gasket may be polluted or damaged).
- Perhaps you have overloaded the appliance with fresh food.
- Insufficient cooling of compressor and condenser.
- Check the air circulation through the bottom rail openings and clean or vacuum the dust from the condenser if necessary. See section *Cleaning and maintenance*.

Ice Formation on the inner rear wall

As long as water is drained through the hole in the rear and into the receptacle at the bottom of the appliance, normal automatic defrosting of the appliance is guaranteed.

If ice formation on the inner back wall is increased (3-5 mm), ice should be manually defrosted.

Set the thermostat knob to **STOP (0)** position and leave the door open. Never use electric devices for defrosting and do not scrape the ice or frost layer with sharp objects.

After completed defrosting turn the knob to desired position and close the refrigerator door. The cause of increased ice formation may be one of the following:

- the door does not seal well (clean the gasket if it is contaminated or replace it if it is damaged);
- the door was frequently opened or it was left opened for too long;
- the food stored in the refrigerator was warm;
- an item is touching the inner back wall.

Sound alarm

Excessive dust on the condenser unit is signalled by a sound alarm heard whenever appliance door is opened until the default is removed.

Check the air circulation through the bottom rail openings and clean or vacuum the dust from the condenser if necessary. See section *Cleaning and maintenance*.

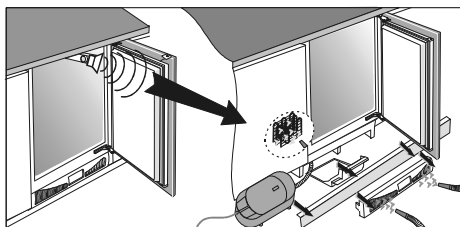

Water drains into the bottom compartment of the appliance

Water will leak from the refrigerator if the drain hole is clogged or if the water is dripping past the collection gutter.

- Clean the clogged outlet, for example with a plastic straw.
- Manually defrost the increased ice layer. See *Ice formation on the inner rear wall*.

Noise

Cooling in refrigerating-freezing appliances is enabled by the cooling system with a compressor which produces some noise. How noisy the appliance is depends on where it is placed, how it is used and how old the appliance is.

- **During the operation** of the compressor the noise of liquid is heard and when the compressor is not operating, the refrigerant flow is heard. This is a normal condition and it has no influence whatsoever on the lifetime of the appliance.
- **After starting the appliance**, the operation of the compressor and the refrigerant flow may be louder, which does not mean that something is wrong with the appliance and which has no effect on the useful life of the appliance. Gradually the noise is reduced.
- Sometimes **unusual and stronger noise** is heard, which is rather unusual for the appliance. This noise is often a consequence of inadequate placing.
 - The appliance shall be placed and levelled firmly on a solid base.
 - It should not touch the wall or kitchen units standing next to it.
 - Check the accessories in the interior of the appliance; they should be placed correctly in their positions. Also check the bottles, tins and other vessels that might touch each other and rattle.

Bulb Replacement

Before replacing the light bulb, disconnect the appliance from the power supply.

Press the cover at the rear side (in the direction of arrow 1) and remove the plastic cover (in the direction of arrow 2). Replace the bulb with a new one (E14, max. 15 W).

Don't forget: the old bulb does not belong in organic waste.

Light bulb is a consumable part that is not covered by our warranty.

Bulb lamps used in this appliance are special purpose lamps selected for household appliances use only. They are not suitable for household room illumination.

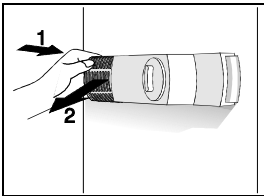

WE RESERVE THE RIGHT TO ALTER THE SPECIFICATIONS THAT DO NOT AFFECT THE OPERATION OF THE APPLIANCE.

Instructions for use of the appliance can also be found on our website at www.gorenje.com / <http://www.gorenje.com> / >