

The Hisense logo is rendered in a bold, black, italicized sans-serif font. The letters are thick and slanted to the right, giving it a dynamic and modern appearance. The background of the page features a series of overlapping, light gray circular arcs that create a sense of motion and depth, framing the central text.

Hisense

USE AND INSTALLATION INSTRUCTIONS

Thank you very much for purchasing this Interface unit. Please read this use and installation instructions carefully before installing and using this appliance and keep this manual for future reference.

Contents

1. Safety precautions	1
2. Installing the interface unit	4
3. System	5
4. Electrical work.....	7

1. Safety precautions

1.1. Cautions Important notice

1. Important notice

- We pursue a policy of continuing improvement of products. The right is therefore reserved to vary specifications without notice.
- Our liability shall not cover occasional damage accidents arising from using this equipment in specific environment.
- No part of this manual may be reproduced without written permission.
- Signal words (DANGER, WARNING and CAUTION) are used to identify levels of hazard seriousness.
- Definitions for identifying hazard levels are provided below with their respective signal words.



: Hazards or unsafe practices which WILL result in severe personal injury or death.



: Hazards or unsafe practices which COULD result in severe personal injury or death.



: Hazards or unsafe practices which COULD result in minor personal injury or product or property damage.

NOTE: Hints and instructions for operation, maintenance and repair are as shown above.

- Installation, maintenance and care of equipment must be performed by qualified professionals.
- If you have any doubt, please contact with your dealer or the service center.
- This manual should be considered as a permanent part of the equipment and should remain with the air conditioning equipment.

2. Checking product received

- Upon receiving this product, inspect it for any shipping damage. Claims for damage, either apparent or concealed, should be filed immediately with the shipping company.
- Please check whether accessories are complete by referring to packing list.
- Check the model No., electrical characteristics (power supply, voltage and frequency) and accessories to determine whether they are correct.
The standard utilization of the unit shall be explained in these instructions. Therefore, the utilization of the unit other than those indicated in these instructions is not recommended.
- Follow local codes and regulations when installing it.
- Please contact your local agent, as the occasion arises.

Our company disclaim all responsibility for changing the equipment without our company's written consent.

1. Safety precautions

3. Security overview



- Do not install by yourself. Please entrust professionals or authorize your dealer to install. If you install by yourself or install improperly, it may cause electric shock or fire accident.
- Installation works shall be carried out correctly by referring to this installation manual. If not, it may cause electric shock or fire accident, etc.
- Never operate with wet hands or spray water to the product. All these products are equipped with electrical components, spraying of water may cause severe electric shock hazard or short-circuit accident.
- Never touch or adjust safety devices in the equipment. If these devices are touched or adjusted, it may cause a serious accident.
- Never open enclosure of equipment to repair without turning OFF the main power supply.
- Cables of specified specifications shall be used during wiring, be reliably connected and avoided from being nipped by enclosure.
The terminal connection shall be secured reliably, and the cables and wiring terminals shall be avoided from being subjected to any external force, or the wiring would be poor and would cause overheating, fire or other hazards.
- During installation, please use the components provided with the equipment together or appointed components. If any component which is not appointed by our company is used, it may cause electric shock, fire or other accidents.
- Please stably install to a place where weight of the machine can be supported fully, or it may lead to falling of machine body and injury.
- After the equipment is installed, turn it on to carry out electric leakage test.

1. Safety precautions



WARNING

- Do not install in following places, or it may cause fire, machine deformation or faults.
- *Places where oil (including machinery oil) mist and steam drift.
- *Places where sulfide gas drifts (such as in hot spring).
- *Places where there are inflammable gases.
- *Coastal areas and the places where the machine body will be corroded by salt, strong acid or alkali.
- *Places where the temperature is high or there is open fire, or it may cause heat generator or fire.
- *Places which are close to the machine generating electromagnetic wave. The electromagnetic wave may influence remote control system and disturb normal operation of controller.
- *Places where there is a lot of moisture or that may be wetted. Once water enters into equipment, it may not only cause electric shock, but also may cause fault of internal electrical components.
- Do not carry out machine installation, wire connection or other installation works if you have not read this installation manual.
- Do not use any sprays such as insecticide, lacquer, hair spray or other poisonous gases within approximately 1 meter from the system.
- If circuit breaker or fuse is often activated, contact your local dealer timely.
- Please carry out installation construction and wire connection construction by strictly referring to this installation and maintenance manual, or it may cause electric shock and fire accident, etc.
- Never put any unrelated material on or in the unit.
- Protect the wires and electrical parts from rats or other small animals. If not, rats may gnaw at the unprotected parts and at the worst, a fire may occur.
- Tighten cables because external stress may cause fire hazard.
- If indoor distribution board or fuse is often activated, stop the air-conditioning system and contact local agent.





CAUTION

- Do not install the indoor unit, outdoor unit, interface unit, wired controller or cable within approximately 3 meters from strong electromagnetic wave radiators (such as medical equipment).
- Do not step or put any material on the product.
- In order to ensure that the temperature sensor in wired controller operates normally, please select installation location according to followings:
 - A. Places where average room temperature can be detected.
 - B. Places which is kept out of direct sunlight.
 - C. Places where there is no heat/cold source nearby.
- Do not play with the interface unit.

2. Installing the interface unit

2.1. Check the parts (Fig. 2.1.1)

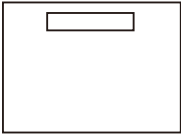
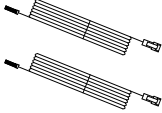
The interface unit should be supplied with the following parts.

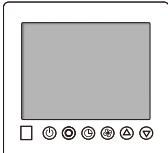
Interface unit	Thermistor	Remote controller cable (5m) (Optional)	Remote controller (Optional)
			
1 pc	2 pcs	1 pc	1 pc

<Fig.2.1.1>

2.2. Choosing the interface unit installation

- Do not install the interface unit in outdoor location as it is designed for indoor installation only.(The interface board and casing are not waterproof.)
- Avoid locations where the unit is exposed to direct sunlight or other sources of heat.
- Select a location where easy wiring access to the power source is available.
- Avoid locations where combustible gases may leak, be produced, flow, or accumulate.
- Select a level location that can bear the weight and vibration of the unit.
- Avoid locations where the unit is exposed to oil, steam, or sulfuric gas.
- Do not install in location that is hot or humid for long period of time.

2.3. Installing the interface unit (Fig.2.3.1,2.3.2,2.3.3)

- Remove 2 screws A from interface unit and remove the cover by sliding it upward (see Fig. 2.3.1).
- Install the 4 screws (locally supplied) in 4 holes (C hole).
- * To prevent the unit from falling off the wall, select the appropriate screws (locally supplied) and secure the base horizontally to the appropriate wall location (See Fig. 2.3.2).

A Screw B Cover C Hole for installation

	Part Name
Weight	2.1kg+ ACCESSORIES 0.8kg
Allowable ambient temperature	0 to 35 °C
Allowable ambient humidity	80% RH or less

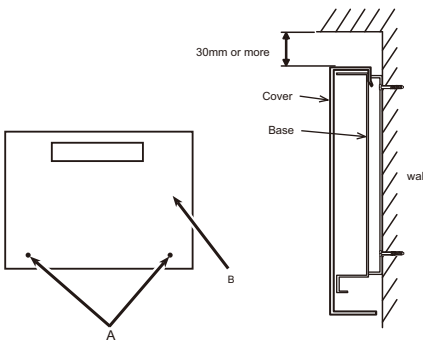

<Fig.2.3.1>

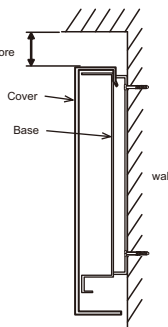

<Fig.2.3.2>
Service space

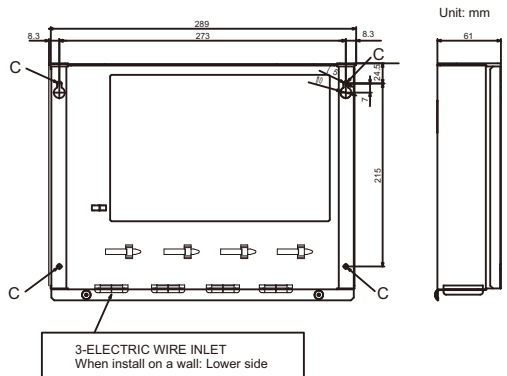

<Fig.2.3.3>

3. System

3.1. System configuration

(Single outdoor unit.)

*1. Interface system receives step request signal correspond to total capacity of outdoor units, and calculates necessary capacity for each outdoor unit automatically.

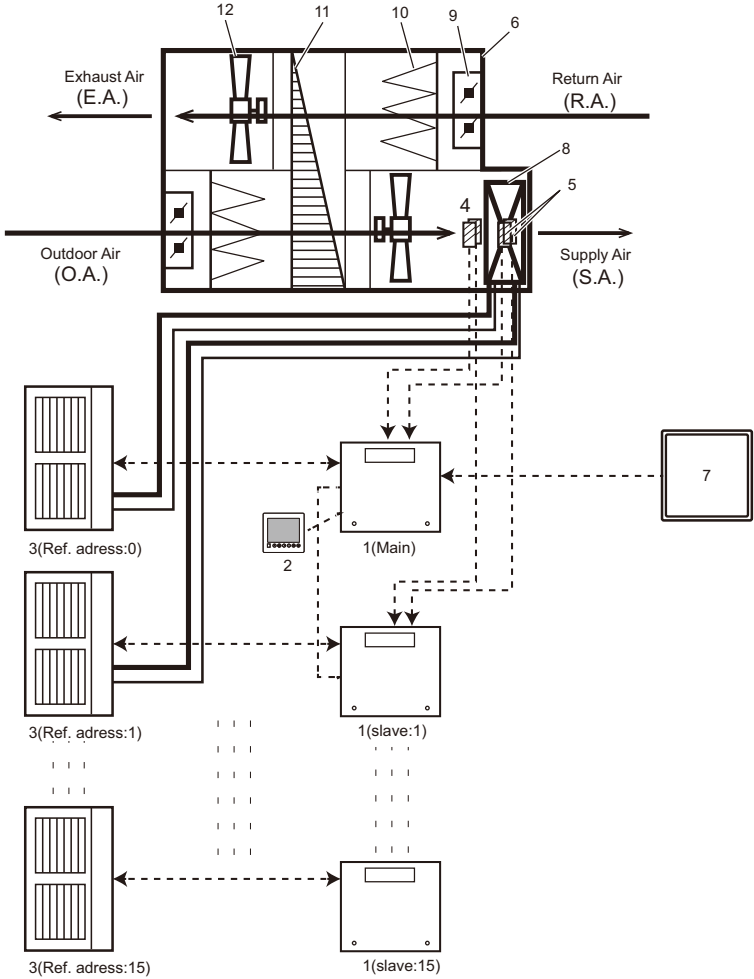

<Fig.3.1.1>

3. System

Note

- Interface unit which the Ref. address 0, becomes main interface unit.
- Connect AHU local controller (Part No. 7) to the main interface unit.
- Connect ONE remote controller (Part No. 2) to the interface unit.
- Connect between the interface units with a remote controller (daisy chain).
- Do NOT select STEP 0 for 3 minutes after compressor is ON. (Keep compressor ON for 3 minutes at least.)
- When changing STEP, make it less than 5 steps in a single operation, and keep at least 5 minutes interval between the changes.
- Keep operation range shown at the following section 3.2.
- Do NOT send STEP 0 during defrost operation.
- Do NOT change operation mode frequently.

No.	Part name	System
1	Interface unit	✓
2	Remote controller	✓
3	Outdoor unit	✓
4	Target air temp. thermistor (TH1)	✓
5	Coil temp. thermistor (TH2)	✓
6	Air-Handling Unit(AHU) (Local supply)	✓
7	Analog input/remote switch/modbus	✓
8	Heat exchanger of AHU (Local supply)	✓
9	Louver (Local supply)	✓
10	Airfilter (Local supply)	✓
11	Heat recovery (Local supply)	✓
12	Fan (Local supply)	✓

3.2. Indoor operation range

Mode	Number of outdoor unit	HEX inlet air temp. operation range
Cooling	1 or more	15-32 °C
Heating	1	0-28 °C
	2 or more	5-28 °C

4. Electrical work

4.1. Electrical connection

All electrical work should be carried out by a suitably qualified technician. Failure to comply with this could lead to electrocution, fire, and death. All wiring should be according to national wiring regulations. Connections should be made to the terminals indicated in the following figures. Use ring terminals and insulate the wires. Tighten the screw from the bottom terminals first.

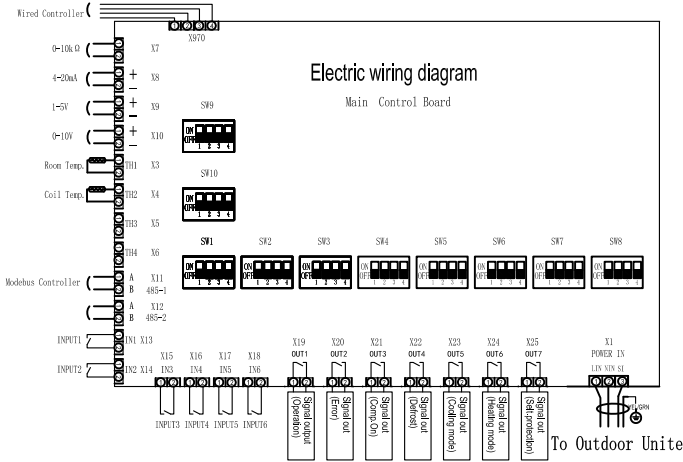

<Fig. 4.1.1>

Notes:

1. Do not run the low voltage cables through a slot that the high voltage cables go through.
2. Do not bundle power cables together with other cables.
3. Bundle cables as Fig. 4.1.1 by using clamps.

4.1.1 Interface unit power supplied from outdoor unit

The following connection patterns are available. The outdoor unit power supply patterns vary on models.

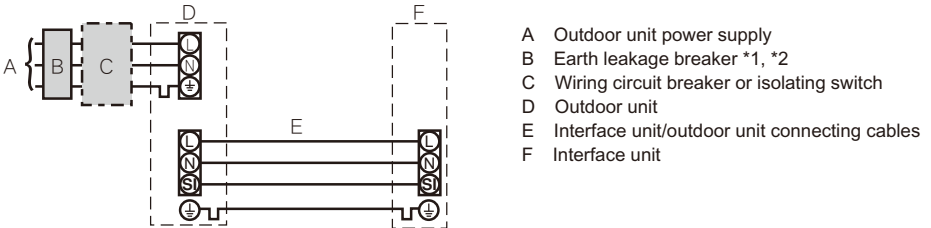

Notes:

In accordance with IEE regulations the circuit breaker/isolating switch located on the outdoor unit should be installed with lockable devices (health and safety).

Wiring Wire No. x size (mm ²)	Interface unit-Outdoor unit *3	3×1.5(polar)
	Interface unit-Outdoor unit earth *3	1× Min. 1.5
Circuit rating	Interface unit-Outdoor unit *4	230V AC

4. Electrical work

• Capacity setting

Analog input			Step for capacity setting		Remote switch				Step for capacity setting		Remark
Variable resistor (0-10K Ω)	4-20mA	1-5V	0-10V	Analog input	X16 (COM-IN4)	X15 (COM-IN3)	X14 (COM-IN2)	X13 (COM-IN1)	Remote SW (Type A)	Remote SW (Type B)	
OPEN(12K Ω -)	-	-	-	OFF	OFF	OFF	OFF	ON	Auto	Auto	Stop
10K Ω	-	-	-	Auto	ON	ON	OFF	OFF	Step11	-	Auto step mode
7.5K Ω	19-20mA	4.75-5V	9.75-10V	Step11	Max.	-	-	-	Max.	-	
-	-	-	9.02V	Step10	-	-	-	-	-	-	
5.6K Ω	17mA	4.25V	8.20V	Step9	OFF	ON	ON	OFF	Step9	-	
4.3K Ω	15mA	3.75V	7.38V	Step8	ON	OFF	ON	OFF	Step8	-	
-	-	-	6.56V	Step7	-	-	-	-	-	-	
3.3K Ω	13mA	3.25V	5.75V	Step6	OFF	OFF	ON	OFF	Step6	Step11	Hz fixed mode
-	-	-	4.93V	Step5	-	-	-	-	-	-	
2K Ω	11mA	2.25V	4.11V	Step4	ON	ON	OFF	OFF	Step4	-	
1K Ω	9mA	2.25V	3.29V	Step3	OFF	ON	OFF	OFF	Step3	Step6	
-	-	-	2.47V	Step2	-	-	-	-	-	-	
510 Ω	7mA	1.75V	1.66V	Step1	ON	OFF	OFF	OFF	Step1	Step1	Min.
0-100 Ω	4-5mA	0-1.25V	0-0.63V	OFF	OFF	OFF	OFF	OFF	OFF	OFF	Stop

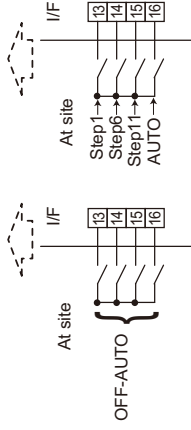

4. Electrical work

• 4-20mA/ 1-5V/ 0-10V/ 0-1kΩ

(1) Use 4-20mA/ 1-5V/ 0-10V

Connect the transmission cables to X8/X9/X10 on the terminal block.

No. 1 on the terminal block: Plus side

No. 2 on the terminal block: Minus side (Reference side)

(2) Use variable resistor(0-10kΩ)

Connect the transmission cables to X7 on the terminal block.

Note:

The values of the “capacity setting” table on the previous page show the center of the input value.

Cable length: Maximum 10m

• Remote switch Type A(4bit -8 setting)/Type B(1bit -1 setting)

Demand control is available by connecting remote switches with terminal No.13-16.

Make sure to use the non-voltage switch (for the remote switch)

Remote switch cable length: Maximum 10m

Remote switch: Minimum applicable load 12V DC, 1mA

(2) Use variable resistor(0-10kΩ)

Connect the transmission cables to X7 on the terminal block.

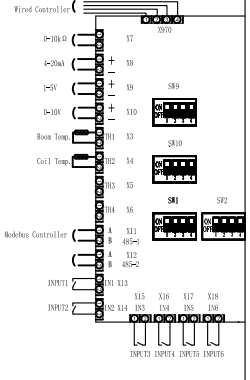

<Photo 4.1.4>

Note:

When using intelligent multiple outdoor unit control function, input the capacity request signal to the main interface which connects to the ref. address 0 outdoor unit.

• External function setting

This function is setting operation mode or stopping compressor, by the external signal

	Item	OFF	ON	Remark
X17(IN5)	Forced Comp. OFF *1	Normal	Forced Comp. OFF	
X18(IN6)	Fixed operation mode	Cooling	Heating	Available when SW2-3 and SW2-4 ON

*1 The operation continues during defrosting operation.

The “Forced Comp. OFF” signal should not be turned ON frequently. It should only be used if an abnormality occurs.

Cable length: Maximum 10m

Remote switch: Minimum applicable load 12V DC, 1mA

⚠ Caution:

The external input signals are separated by basic insulation from power supply for the unit.

The external input signals should be separated by supplementary insulation from where user may touch in case that it is installed where user may touch.

Connect the terminals by using the ring terminals and also insulate the cables of adjoining terminals when wiring to terminal block.

4.1.4 Connecting External Output

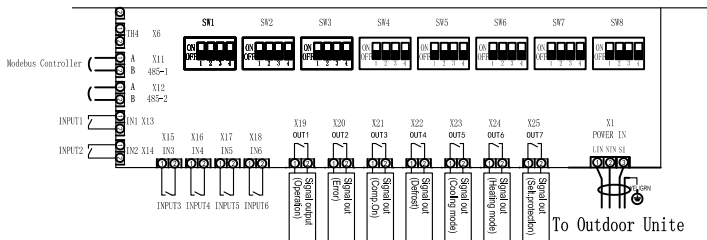

4. Electrical work

Table 1 External outputs

Name	Terminal	Item	OFF	ON
OUT1	X19	Operation Output	OFF	ON
OUT2	X20	Error Output	Normal	Error
OUT3	X21	Comp.ON Output	OFF(Comp.OFF)	ON(Comp. ON)
OUT4	X22	Defrost Output	OFF	ON(Defrosting)
OUT5	X23	Cooling mode Output	OFF	ON(Cooling)
OUT6	X24	Heating Mode Output	OFF	ON(Heating)
OUT7	X25	Self protection Out	OFF	ON

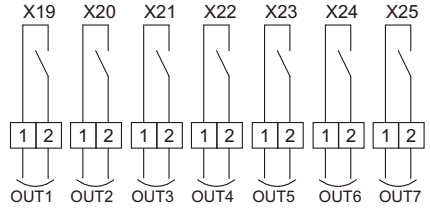

*1 The output may not be available depending on connected outdoor unit models.

Cable length: Maximum 50m

Output specification: Non-voltage switch 1A, 240V AC/30V DC or less
10mA, 5V DC or more

*Connect the surge absorber according to the load at site.

Note:

- External output signals are separated by basic insulation from other circuit of interface.

⚠ Caution:

When 2 or more external outputs are used, the power supply on the output side should be the same.

4.1.5 Switch setting

It is necessary to set the following function by setting the switch of the interface controller before use.

• SW1: Fixed operation mode

SW1-1	SW1-2	SW1-3	SW1-4	Input
OFF	OFF	OFF	OFF	Remote switch Type A(4bit-8setting)
OFF	OFF	OFF	ON	Remote switch Type B(1bit-1setting)
OFF	OFF	ON	OFF	Analog (4 - 20 mA)
OFF	OFF	ON	ON	Analog (1 - 5 V)
OFF	ON	OFF	OFF	Analog (0 - 10V)
OFF	ON	OFF	ON	Analog (0 - 10 kΩ)
OFF	ON	ON	OFF	No input (Auto step mode)
OFF	ON	ON	ON	Modbus

• SW2: Fixed operation mode

SW2-1	SW2-2	SW2-3	SW2-4	Details
OFF	OFF	OFF	OFF	No fixed (Remote controller setting)
OFF	OFF	OFF	ON	Cooling Fix
OFF	OFF	ON	OFF	Heating Fix
OFF	OFF	ON	ON	External Input (Input5 , Input6)

• SW3: Fixed set temperature(for auto mode)

SW3-1	SW3-2	SW3-3	SW3-4	Details
OFF	OFF	OFF	OFF	Not Fixed (Remote controller setting)
OFF	OFF	OFF	ON	16°C FIX
OFF	OFF	ON	OFF	17°C FIX
OFF	OFF	ON	ON	18°C FIX
OFF	ON	OFF	OFF	19°C FIX
OFF	ON	OFF	ON	20°C FIX
OFF	ON	ON	OFF	21°C FIX
OFF	ON	ON	ON	22°C FIX
ON	OFF	OFF	OFF	23°C FIX
ON	OFF	OFF	ON	24°C FIX
ON	OFF	ON	OFF	25°C FIX
ON	OFF	ON	ON	26°C FIX
ON	ON	OFF	OFF	27°C FIX
ON	ON	OFF	ON	28°C FIX
ON	ON	ON	OFF	29°C FIX
ON	ON	ON	ON	30°C FIX

• SW5: Fixed additional function selection

SW5-1	SW5-2	SW5-3	SW5-4	Details
--	--	--	OFF	AHU local controller synchronous control invalid
--	--	--	ON	AHU local controller synchronous control valid
--	--	OFF	--	Modbus mode: Room temp. from AHU local controller setting
--	--	ON	--	Modbus mode: Room temp. from modbus setting

4. Electrical work

• SW4: Fixed indoor room temp. compensation

SW4-1	SW4-2	SW4-3	SW4-4	Details
OFF	OFF	OFF	OFF	No compensation
OFF	OFF	OFF	ON	1°C
OFF	OFF	ON	OFF	2°C
OFF	OFF	ON	ON	3°C
OFF	ON	OFF	OFF	4°C
OFF	ON	OFF	ON	-1°C
OFF	ON	ON	OFF	-2°C
OFF	ON	ON	ON	-3°C
ON	OFF	OFF	OFF	-4°C

• SW7: Fixed outdoor capacity setting (W/BTU)

SW7-1	SW7-2	SW7-3	SW7-4	Outdoor capacity
OFF	OFF	OFF	OFF	7200/24K
OFF	OFF	OFF	ON	2200/7K
OFF	OFF	ON	OFF	2500/8K
OFF	OFF	ON	ON	2800/9K
OFF	ON	OFF	OFF	3200/10K
OFF	ON	OFF	ON	3600/12K
OFF	ON	ON	OFF	4000/13K
OFF	ON	ON	ON	4600/15K
ON	OFF	OFF	OFF	5000/17K
ON	OFF	OFF	ON	5600/19K
ON	OFF	ON	OFF	6300/21K
ON	OFF	ON	ON	7100/24K
ON	ON	OFF	OFF	8000/27K
ON	ON	OFF	ON	11200/38K
ON	ON	ON	OFF	14000/47K
ON	ON	ON	ON	24000/81K

4.1.6 Before test run

After completing installation and the wiring and piping of the local application and outdoor units, check for refrigerant leakage, looseness in the power supply or control wiring, wrong polarity, and no disconnection of one phase in the supply.

Use a 500-volt megohmmeter to check that the resistance between the power supply terminals and ground is at least 1.0MΩ.

⚠ Warning:

Do not use the system if the insulation resistance is less than 1.0MΩ.

⚠ Caution:

Do not carry out this test on the control wiring (low voltage circuit) terminals.

• SW6: Fixed Slave address setting(when Sw1 select Modbus mode)

SW6-1	SW6-2	SW6-3	SW6-4	Slave address
OFF	OFF	OFF	OFF	1
OFF	OFF	OFF	ON	2
OFF	OFF	ON	OFF	3
OFF	OFF	ON	ON	4
OFF	ON	OFF	OFF	5
OFF	ON	OFF	ON	6
OFF	ON	ON	OFF	7
OFF	ON	ON	ON	8
ON	OFF	OFF	OFF	9
ON	OFF	OFF	ON	10
ON	OFF	ON	OFF	11
ON	OFF	ON	ON	12
ON	ON	OFF	OFF	13
ON	ON	OFF	ON	14
ON	ON	ON	OFF	15
ON	ON	ON	ON	16

• SW8: Fixed Slave address setting(when AHU local controller synchronous control valid)

SW8-1	SW8-2	SW8-3	SW8-4	Slave address
OFF	OFF	OFF	OFF	Default as host unit
OFF	OFF	OFF	ON	1
OFF	OFF	ON	OFF	2
OFF	OFF	ON	ON	3
OFF	ON	OFF	OFF	4
OFF	ON	OFF	ON	5
OFF	ON	ON	OFF	6
OFF	ON	ON	ON	7
ON	OFF	OFF	OFF	8
ON	OFF	OFF	ON	9
ON	OFF	ON	OFF	10
ON	OFF	ON	ON	11
ON	ON	OFF	OFF	12
ON	ON	OFF	ON	13
ON	ON	ON	OFF	14
ON	ON	ON	ON	15

4. Electrical work

4.2. Connecting the remote controller

Connect the remote controller cable to Interface unit

Connect the remote controller cable to 1 and 1 on the terminal block(X970) on the interface controller. <Fig.4.2.1>

Wire wire No.x size(mm²): 2×0.3

Wiring size must comply with the applicable local and national codes.

Circuit rating: 12V DC

Circuit rating is NOT always against the ground.

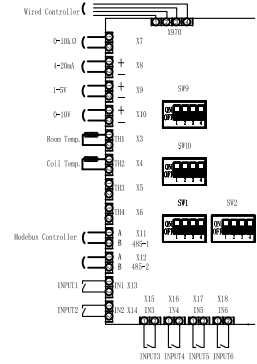

Note:

1. Wiring for remote controller cable shall be (5cm or more) apart from power source wiring so that it is not influenced by electric noise from power source wiring.(Do not insert the remote controller cable and power source wiring in the same conduit.) (Refer to Fig.4.1.1)
2. When wiring to X970, use the ring type terminals and insulate them from the cables of adjoining terminals.
3. Installing the remote controller according to the remote controller installation manual.

