

Hisense

life reimagined

USER'S OPERATION MANUAL

Before operating this unit, please read this manual thoroughly, and retain for future reference

WD5S1045BW
WD5S1045B*
WD5S1245BW
WD5S1245B*

English

This washer dryer is intended solely for household use.
Please do not use it for any laundry labelled as not suitable for machine washing.

The following symbols are used throughout the manual and they have the following meanings:



Information, advice, tip, or recommendation



Warning – general danger



Warning – danger of electric shock



Warning – danger of hot surface



Warning – danger of fire



It is important that you carefully read the instructions.

CONTENTS

4 SAFETY PRECAUTIONS 12 WASHER DRYER DESCRIPTION 13 Technical specifications 14 Control unit	INTRODUCTION
16 INSTALLATION AND CONNECTION 17 Removing the transport screws/rods 18 Moving and transport after installation 19 Selecting the room 19 Adjusting the washer dryer feet 20 Washer dryer installation clearances 21 Connecting to water supply 21 Aqua stop 22 Connecting and securing the water discharge hose 24 Connecting the appliance to the power mains 25 BEFORE USING THE APPLIANCE FOR THE FIRST TIME	PREPARING THE WASHER DRYER BEFORE FIRST USE
26 WASHING PROCESS, STEP BY STEP (1-7) 26 Step 1: Heed the labels on the laundry 27 Step 2: Preparing the washing process 32 Step 3: Choosing the washing programme 36 Step 4: Selecting additional settings and functions 42 Step 5: Starting the washing programme 43 Step 6: Change of washing programme or manual (physical) cancellation 44 Step 7: End of the washing programme 45 INTERRUPTIONS AND CHANGING THE PROGRAMME 47 MAINTENANCE & CLEANING 47 Cleaning the detergent compartment 48 Cleaning the water supply hose, detergent dispenser housing, and rubber door gasket 49 Cleaning the pump filter 50 Cleaning the washer dryer exterior	STEPS OF THE WASHING PROCESS WASHER DRYER CLEANING AND MAINTENANCE
51 TROUBLESHOOTING 51 What to do ...? 52 Troubleshooting and error table 53 Servicing 54 RECOMMENDATIONS FOR WASHING AND ECONOMIC USE YOUR WASHER DRYER 56 Stain removal tips 58 DISPOSAL 58 TYPICAL CONSUMPTION TABLE 60 Wi-Fi connection	TROUBLE-SHOOTING MISCELLANEOUS

SAFETY PRECAUTIONS



Carefully read the instructions for use before using the washer dryer.

Please, do not use the washer dryer without reading and understanding these instructions or use first.

These instructions for use of a washer dryer are supplied with different types or models of washer dryer. Therefore, they may include descriptions of settings or equipment that are not available in your washer dryer.

Failure to observe the instructions for use or inappropriate use of the washer dryer may result in damage to the laundry or the appliance, or injury to the user. Keep the instruction manual handy, near the washer dryer.

Your washer dryer is intended solely for household use. If the washer dryer is used for professional, for-profit purpose or purpose exceeding normal use in a household, or if the washer dryer is used by a person who is not a consumer, the warranty period shall be equal to the shortest warranty period required by relevant legislation.

Follow the instructions for correct installation of the washer dryer and connection to the water and power mains (see chapter »INSTALLATION AND CONNECTION«).

Connection to water and power supply has to be executed by an adequately trained technician or expert.

Any repair and maintenance pertaining to safety or performance should be done by trained experts.

To avoid danger, **a damaged power** cord may only be replaced by the manufacturer, a service technician, or an authorized person.

Before connecting the washer dryer to the power mains, wait for at least 2 hours until it reaches room temperature.

This product must be serviced by an authorized Service Center, only use approved spare parts by authorized manufacturers.

Under no circumstances should you attempt to repair the appliance yourself. Repairs carried out by inexperienced persons may cause injury or more serious malfunctioning. Refer to your local Service Center, and always insist on genuine spare parts.

In case of incorrect washer dryer connection, incorrect use, or servicing by an unauthorized person, the user shall bear the cost of any damage as such damage shall not be covered by warranty.

The washer dryer may not be connected to the power mains using an extension cord.

Do not connect the washer dryer to power mains using an external switching device such as a programme timer, or connect it to power mains that is regularly switched on and off by the power supply provider.

Do not connect the washer dryer to an electrical outlet intended for an electric shaver or hair dryer.

The power socket has to be safely earthed, and the water supply should be unimpeded.

Do not install the washer dryer in a room where the temperature can drop to below 5°C, as washer dryer parts may be damaged in case of water freezing.

Place the washer dryer on a level and stable solid (concrete) base.

If the washer dryer is placed on an elevated stable base, the washer dryer has to be additionally secured against tipping.

Before the first use of the washer dryer, remove the transport screws, as switching on a blocked washer dryer can result in serious damage (see chapter »INSTALLATION AND CONNECTION/Removing the transport screws«). Warranty shall be void in cases of such damage.

To connect the washer dryer to water supply, make sure to use the supplied water supply hose and gaskets. Water pressure has to be between 0.1–1 MPa (1-10 bar; 1–10 kp/cm²; 10–100 N/cm²).

Always use a new water supply hose to connect the washer dryer to water supply; do not reuse an old water supply hose.

The end of the water discharge hose should reach into a water drain line.

Before the start of the washing cycle, press the door on the indicated spot until it locks into place. The door cannot be opened during washing machine operation.

We recommend removing any impurities from the washer dryer drum before the first wash using the Drum clean programme (see PROGRAMME TABLE).

After the washing cycle, close the water tap and pull out the washer dryer plug from the power socket.

Only use agents for washer dryer and care of laundry. We shall not be responsible for any damages or discolouration of gaskets and plastic parts resulting from incorrect use of bleaching or colouring agents.

When descaling, only use descaling agents with added anti-corrosion protection. (Only use non-corrosive descaling agents.) Follow the manufacturer's instructions. Finish the descaling process with several rinse cycles or by running the Drum clean (Self cleaning programme) in order to remove any residual acid (e.g. vinegar etc.).

 Do not use detergents that contain solvents as this could lead to release of poisonous gases, damage to the washer dryer, and risk of fire and explosion.

No silver ions are released during the washing programme.

The washer dryer is not intended for use by persons (including children) with physical or mental impairments, or persons with lacking experience and knowledge. These persons should be instructed about the use of the washer dryer by a person responsible for their safety.

The warranty does not cover consumables, minor deviations in colour, increased noise that results from appliance age and which does not affect the functionality of the appliance, and aesthetic defects on components, which do not affect the functionality and safety of the appliance.

CHILD SAFETY

Before closing the washer dryer door and running the programme, make sure there is nothing except laundry in the drum (e.g. if a child climbed into the washer dryer drum and closed the door from the inside).

Keep the detergent and conditioner out of reach of children.

Activate the child lock. See chapter »SELECTING ADDITIONAL SETTINGS AND FUNCTIONS/Child lock«.

Do not let children younger than three years come near the appliance, unless they are under constant supervision.

The washer dryer is made in compliance with all relevant safety standards.

This washer dryer may be used by children aged 8 years and above and by persons with reduced physical, sensory or mental capabilities or lack of experience and knowledge, but only if they are supervised during the use of

the washer dryer, if they have been provided relevant instructions regarding safe use of the washer dryer, and if they understand the hazards of inappropriate use. Make sure children do not play with the appliance. Children may not clean the washer dryer or perform any maintenance tasks without supervision.

DANGER OF HOT SURFACE

At higher washing temperatures, the door glass will heat up. Be careful to avoid burns. Make sure children do not play near the door glass.

WATER OVERFLOW PROTECTION (WITH WASHER DRYER SWITCHED ON)

If the water level in the appliance rises above normal level, then the excess water level protection will be activated. It will shut off the water supply and start pumping out the water. The program is interrupted and an error is reported (see TROUBLESHOOTING TABLE).

TRANSPORT/TRANSPORT AFTER INSTALLATION

If you intend to move the washer dryer after it has been installed, then it should be blocked by inserting the transport screws (see chapter »INSTALLATION AND CONNECTION/Moving and transport«). Before inserting the transport screws, disconnect the washer dryer from the power mains!

If the supply cord is damaged, it must be replaced by the manufacturer, its service agent or similarly qualified persons in order to avoid a hazard.

Water drained during a high-temperature wash or drying cycle is hot. Do not touch the water.

Do not open the washer dryer door by force while it is operating (high-temperature washing/drying/spinning).

That the tumble dryer is not to be used if industrial chemicals have been used for cleaning;

That lint must not be allowed to accumulate around the tumble dryer;

That adequate ventilation has to be provided to avoid the back flow of gases into the room from appliances burning other fuels, including open fires.

Do not dry unwashed items in the tumble dryer.

Items that have been soiled with substances such as cooking oil, acetone, alcohol, petrol, kerosene, spot removers, turpentine waxes and wax removers should be washed in hot water with an extra amount of detergent before being dried in the tumble dryer.

Items such as foam rubber (latex foam), shower caps, waterproof textiles, rubber backed articles and clothes or pillows fitted with foam rubber pads should not be dried in the tumble dryer.

Fabric softeners, or similar products, should be used as specified by the fabric softener instructions.

Remove all objects from pockets such as lighters and matches.

WARNING: Never stop a tumble dryer before the end of the drying cycle unless all items are quickly removed and spread out so that the heat is dissipated.

WARNING: The appliance must not be supplied through an external switching device, such as a timer, or connected to a circuit that is regularly switched on and off by a utility.

For appliances with ventilation openings in the base, a carpet must not obstruct the openings;

The appliance must not be installed behind a lockable door, a sliding door or a door with a hinge on the opposite side to that of the tumble dryer, in such a way that a full opening of the tumble dryer door is restricted.

Exhaust air must not be discharged into a flue that is used for exhausting fumes from appliances burning gas or other fuels;

WASHER DRYER DESCRIPTION

FRONT

- 1 Control unit
- 2 Programme selector knob
- 3 Detergent compartment
- 4 Door
- 5 Rating plate
- 6 Pump filter cover

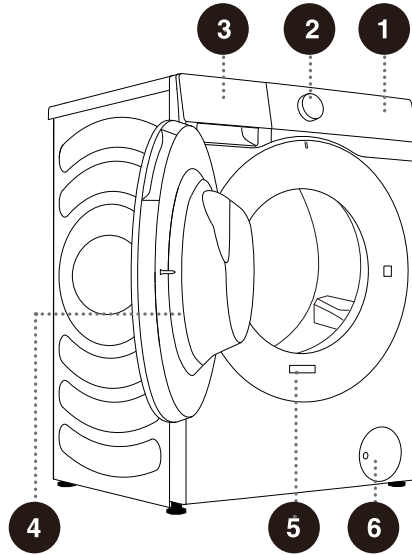

BACK

- 1 Water supply hose
- 2 Power cord
- 3 Water discharge hose
- 4 Adjustable feet
- 5 Blocking rods/screws

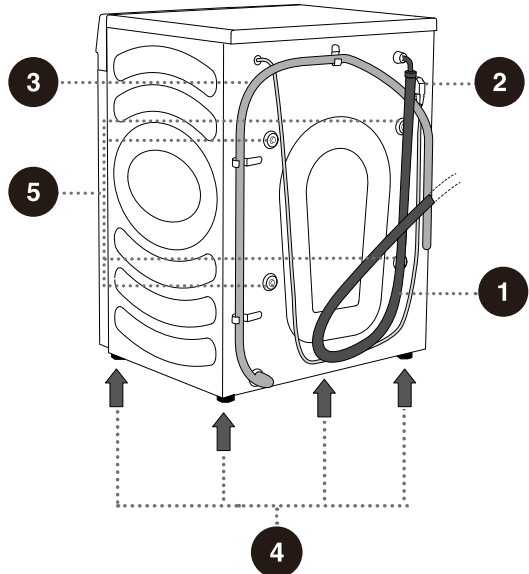

TECHNICAL SPECIFICATIONS

(DEPENDING ON THE MODEL)

Rating plate with basic information about the washer dryer is fitted on the front wall of the washer dryer door opening (see chapter »WASHER DRYER DESCRIPTION«).

Washing/drying Capacity	10.5/6kg	12/8kg
Maximum load	10.5kg	12kg
Washer dryer weight	72kg	74kg
Rated Voltage	220-240V~	
Nominal power	1750W/1350W	
Frequency	50Hz	

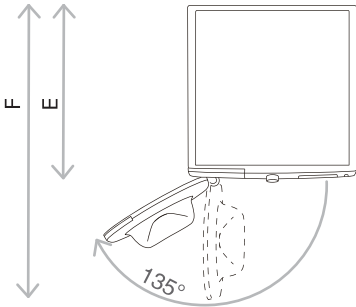

E = Washer dryer depth
F = Depth with door open

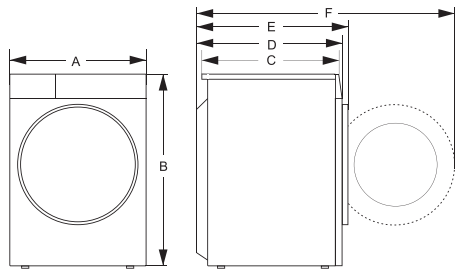

Dimensions(mm)

Index	Dimension(mm)	
Washing/drying Capacity	10.5/6	12/8
A	595	595
B	845	845
C	560	610
D	590	640
E	620	670
F	1100	1150



Rating plate

Hisense Washer-dryer
XXXXXXXXXX
 XXX-XXXV~ XXHz IPX4
 Washing Capacity:XX kg (XXXXW)
 Drying Capacity:X kg (XXXXW)



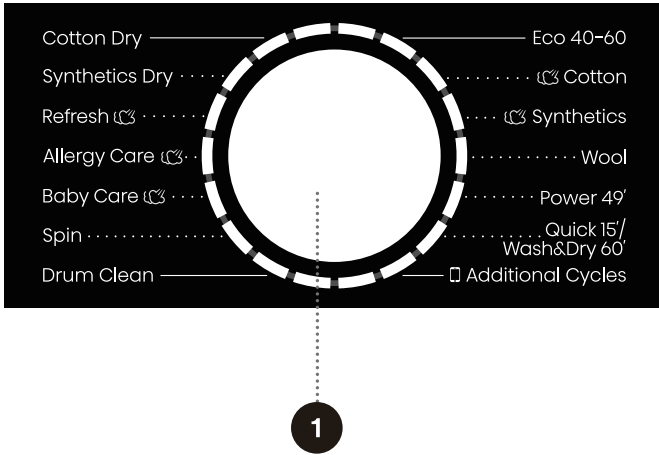

⚠ Before connecting the washer dryer to the power mains, wait for at least 2 hours until it reaches room temperature.

CONTROL UNIT

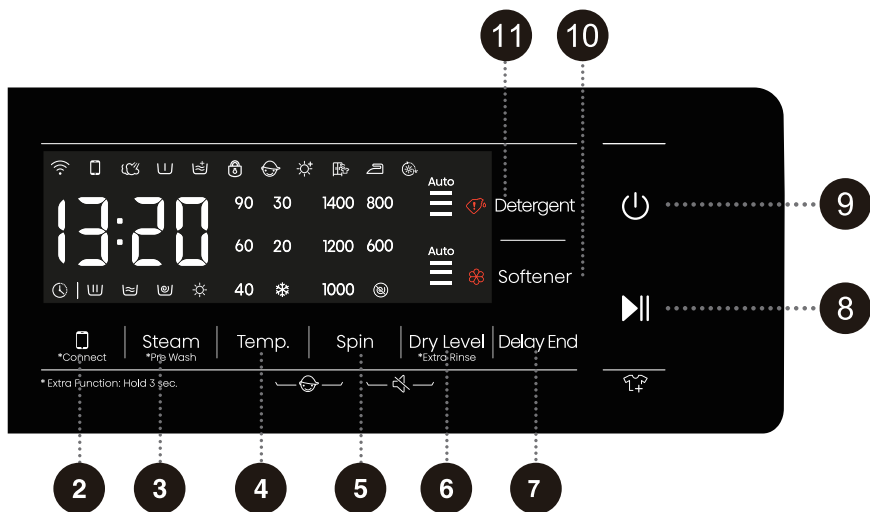

1 PROGRAMME SELECTOR KNOB



2 ***CONNECT**

Washer dryer network control key. See the Wi-Fi guide on the last page for how to configure the network.

5 **SPIN**

Press to change the spinning speed for the current cycle. **NO Spin**: The drum does not spin after the final drain cycle.

8 **START/PAUSE**

Start/Pause the whole machine program running.

10 **SOFTENER**

4+5 **CHILD LOCK**

Press these two keys at the same time to enable or disable the child lock function.

3 **STEAM *PRE WASH**

Add or subtract Steam and Pre wash functions by long press and short press.

6 **DRY LEVEL**

Press the "Dry Level" button to select the dry time and additional functions of dry.

EXTRA RINSE

Press to change the rinse count for current cycle.

9 **POWER**

Press to turn on/off the washing machine.

11 **DETERGENT**

5+6 **MUTE (SWITCHING OFF THE ACOUSTIC SIGNALS)**

4 **TEMP.**

Press to change the water temperature for the selected cycle.

7 **DELAY END**

Delay End lets you set the end time of the current cycle. Based on your settings, the start time of the cycle will be determined by the machine's internal logic. For example, this setting is useful for programming your machine to finish a wash at the time you normally return home from work. Press to choose a preset unit of hours.

For extra function: Press and hold for 3 seconds.

INSTALLATION AND CONNECTION

⚠ Remove all packaging (see chapter »DISPOSAL«). When removing the packaging, make sure not to damage the appliance with a sharp object. Keep the packaging material (plastic bags, other plastic parts etc.) out of reach of children.

Check for any damage on the appliance. If you suspect the appliance is damaged, do not use it and immediately contact the service unit.

The appliance is supplied with a support set that includes:

- Instructions for use,
- 4 plastic plugs,
- supply hose,
- drain hose holder.

Make sure all of the above is supplied.

REMOVING THE TRANSPORT SCREWS/RODS

 Before the first use of the appliance, transport screws/rods must be removed. A blocked appliance may be damaged when it is switched on for the first time. Warranty shall be void in cases of such damage.

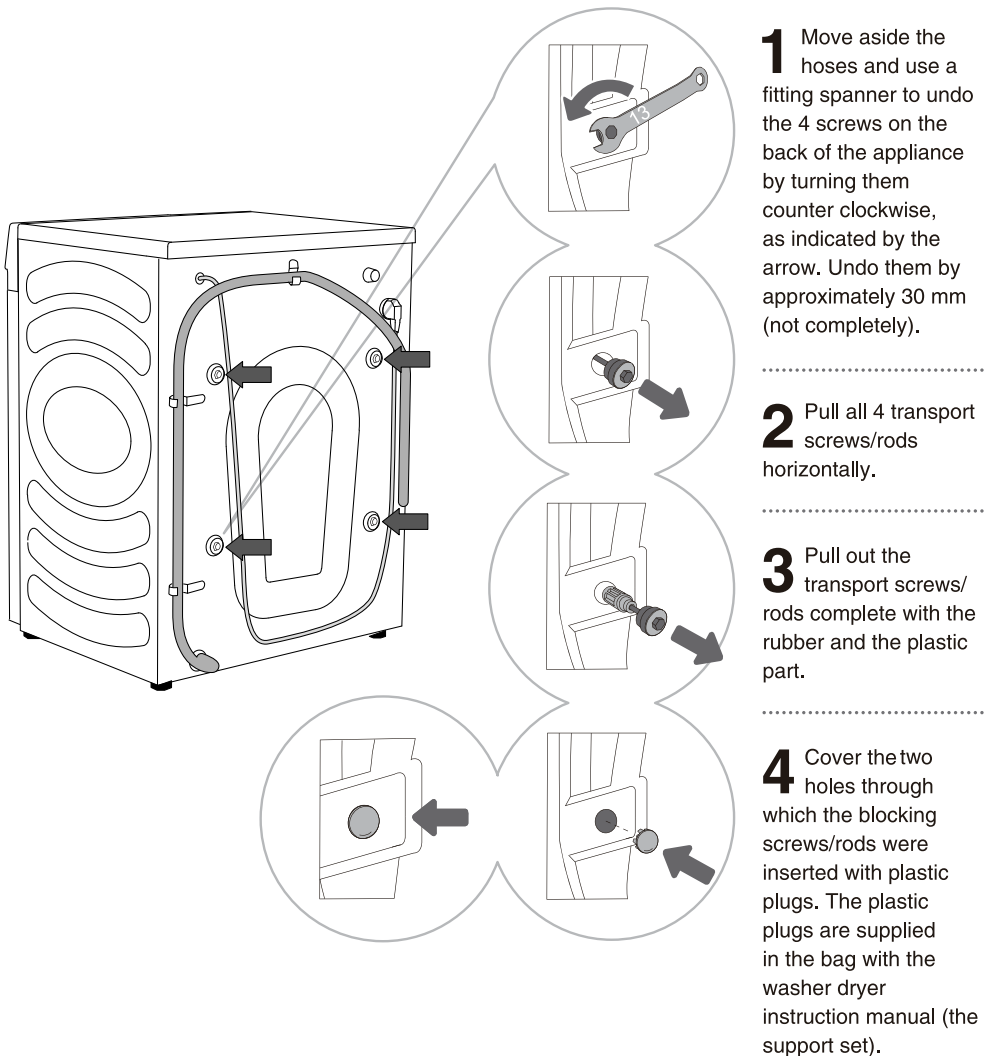

 Save the transport screws/rods in case you have to transport the appliance again later (to reinstall the blocking screws/rods, follow the above procedure in reverse order).

MOVING AND TRANSPORT AFTER INSTALLATION

💡 If you wish to move the washer dryer after it has been installed, the blocking screws/rods have to be re-installed to prevent vibration damage to the washer dryer during transport (see chapter» INSTALLATION AND CONNECTION/Removing the transport screws/rods«). If you lost the blocking screws/rods, they can be ordered from the manufacturer.

⚠ After transport, the washer dryer should be left to stand still for at least two hours before it is connected to the power mains, so that it can reach room temperature. The appliance should be installed and connected by a trained technician.

⚠ Carefully read the instructions for use before connecting the washer dryer. Repair or any warranty claim resulting from incorrect connection or use of the washer dryer shall not be covered by the warranty.

SELECTING THE ROOM

⚠ Floor on which the washer dryer is placed must have a concrete base. It should be clean and dry; otherwise, the washer dryer may slide. Also, clean the bottom surface of adjustable feet.

⚠ The washer dryer must stand level and stable on a solid base.

ADJUSTING THE WASHER DRYER FEET

Use a spirit level and the supplied spanner.

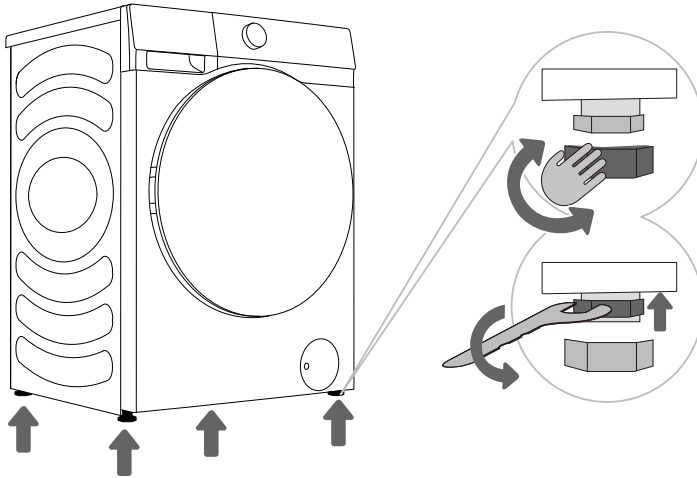

.....

1 Rotate the adjustable feet to level the washer dryer lengthwise and crosswise. The feet allow levelling by +/- 2 cm.

.....

2 After adjusting the height of the feet, firmly tighten the jam nuts (counter nuts) using the supplied spanner by turning them towards the bottom of the washer dryer ↑ (see figure).

⚠ Incorrect levelling of the washer dryer with the adjustable legs may cause vibration, appliance sliding across the room, and loud operation. Incorrect levelling of the washer dryer is not subject to warranty.

⚠ Sometimes, unusual or louder noise may appear during appliance operation; these are mostly the result of improper installation.

WASHER DRYER INSTALLATION CLEARANCES

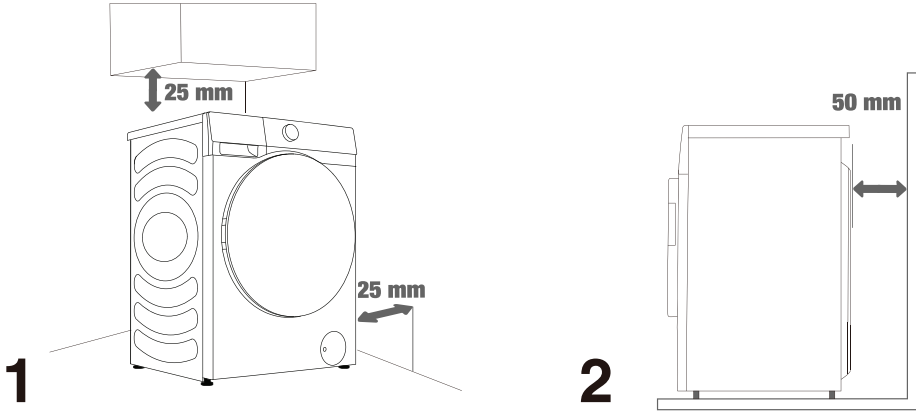

⚠ The washer dryer may not be in contact with a wall or adjacent furniture. For optimum washer dryer operation, we recommend observing the clearances from the walls as indicated in the figure.

In case of failure to observe the minimum required clearances, safe and correct washer dryer operation cannot be ensured. Moreover, overheating can also occur (figures 1 and 2).

⚠ Installing the washer dryer under a countertop is not recommended.

CONNECTING TO WATER SUPPLY

Attach the hose to the water tap by screwing it onto the thread.

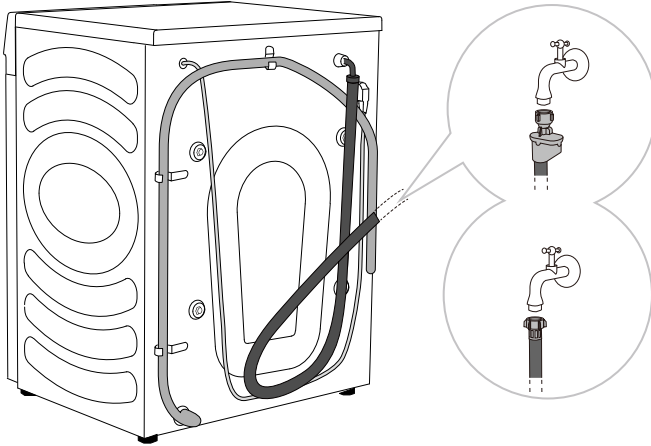

A AQUA STOP

B REGULAR CONNECTION

⚠ For normal washer dryer operation, the pressure in the water mains should be between 0.1–1 MPa (1–10 bar; 1–10 kp/cm²; 10–100 N/cm²). Minimum dynamic water pressure can be determined by measuring the water flow. In 15 seconds, 3 litres of water should flow from a fully open tap.

⚠ Tighten the water supply hose by hand, firmly enough for the hose to have a good seal (max. 2 Nm). After connecting the hose, the seal must be checked for any leaks. Do not use pliers or similar tools when connecting the hose as this could damage the nut thread.

⚠ Only use the water supply hose supplied with the appliance. Do not use any used or other hoses.

⚠ Make sure the hose is not damaged. If the hose is degraded, brittle, or cracked, it has to be replaced.

AQUA STOP (ONLY WITH SOME MODELS)

If an internal tube or hose is damaged, a shut-off system is activated that cuts the water supply to the washer dryer. In such case, the control glass (a) will turn red. Replace the water supply hose.

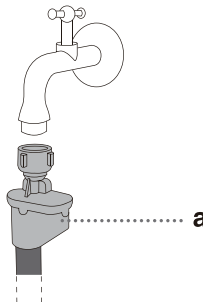

⚠ Do not dip the water supply hose with the Aqua stop system in water as it contains an electric valve.

⚠ The water supply hose can be connected without a non-return valve.

⚠ When connecting the water supply hose, make sure to connect it in a way that allows adequate and unobstructed water supply.

CONNECTING AND SECURING THE WATER DISCHARGE HOSE

Feed the water discharge hose into a washbasin or a bathtub, or connect it directly to a drain (discharge hose minimum diameter 4 cm). The vertical distance from the floor to the end of the discharge hose may be no more than 100 cm and no less than 60 cm. It can be attached in three ways (A, B, C).

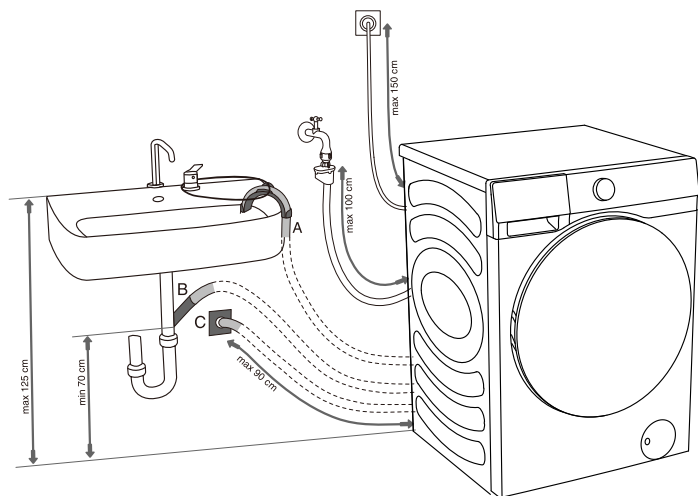

A Discharge hose end may be placed over a sink or a bathtub. B Use a string fed through the opening in the elbow support to attach the hose and prevent it from slipping to the floor.

B Discharge hose may also be attached directly to the sink drain. A sink that is too small is not acceptable. Be careful as the drained water may be hot.

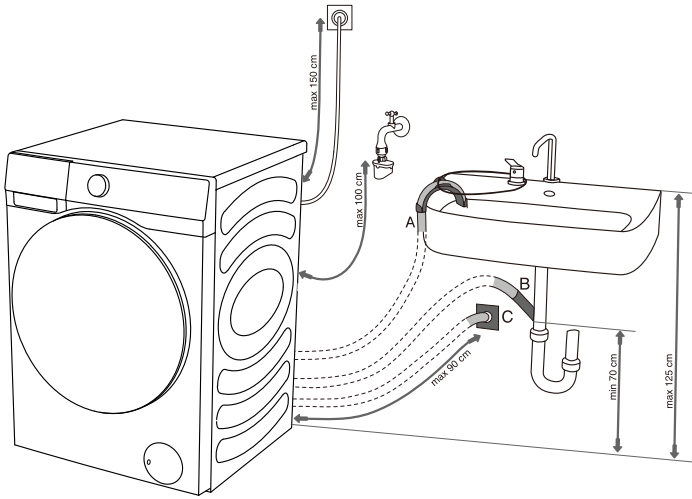

C Discharge hose can also be attached to a wall drain with a trap; such trap should be properly installed to allow cleaning.

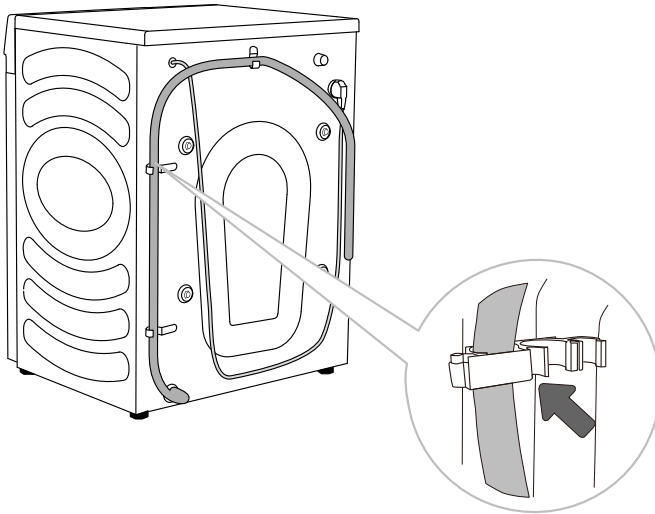

D The discharge hose has to be attached and affixed to the pin on the back of the washer dryer, as shown in the figure.

⚠ Make sure the drain hose is not damaged.

⚠ If the discharge hose is not correctly attached, safe and correct washer dryer operation cannot be ensured.

CONNECTING THE APPLIANCE TO THE POWER MAINS

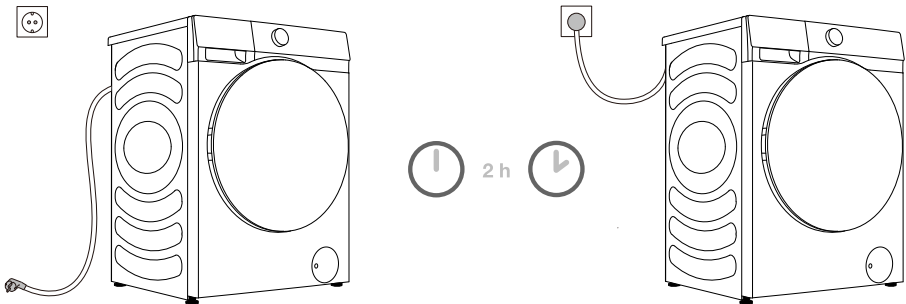

⚠ Before connecting the washer dryer to the power mains, wait for at least 2 hours until it reaches room temperature.

Connect the washer dryer to a grounded power outlet. After installation, the wall outlet should be freely accessible. The outlet should be fitted with an earth contact (in compliance with the relevant regulations).

Information on your washer dryer is indicated on the rating plate.

⚠ We recommend using over-voltage protection to protect the appliance in case of a lightning strike.

⚠ The washer dryer may not be connected to the power mains using an extension cord.

⚡ Do not connect the washer dryer to an electrical outlet intended for an electric shaver or hair dryer.

⚡ Do not plug or unplug the appliance when your hands are wet.

⚡ Any repair and maintenance pertaining to safety or performance should be done by trained experts.

⚡ A damaged power cord may only be replaced by a person authorized by the manufacturer.

BEFORE USING THE APPLIANCE FOR THE FIRST TIME

Make sure the washer dryer is disconnected from the power mains; then, open the door towards you (figures 1 and 2).

Before using the appliance for the first time, clean the drum using a soft and moist cotton cloth, or use the drum clean program. In such case, connect the appliance to the power mains and open the water tap. There should not be any laundry in the drum; the drum should be empty (Figures 3 and 4).

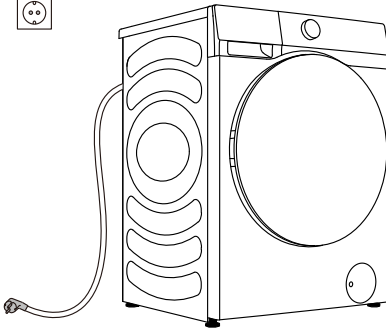

1

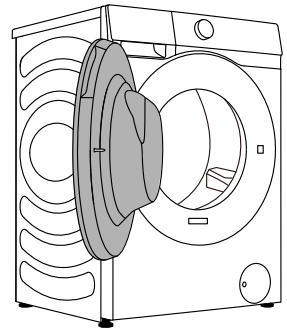

2

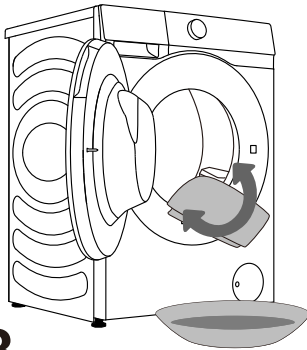

3

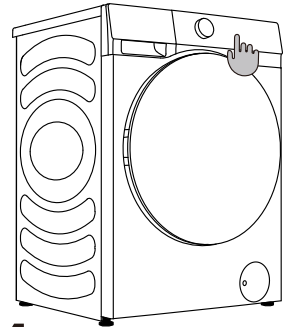



























4

⚠ Do not use any solvents or cleaning agents that could damage the washer dryer (please observe the recommendations and warnings provided by the cleaning agent manufacturers).

WASHING PROCESS, STEP BY STEP (1–7)

STEP 1: HEED THE LABELS ON THE LAUNDRY

Normal wash; Sensitive laundry	Max. washing temp. 95°C  	Max. washing temp. 60°C  	Max. washing temp. 40°C  	Max. washing temp. 30°C  	Hand wash only 	Do not wash 
Bleaching	Bleaching in cool water 			Bleaching not allowed 		
Dry cleaning	Dry cleaning with all agents 	Petroleum solvent R11, R113 	Dry cleaning in kerosene, pure alcohol, and R113 	Dry cleaning not allowed 		
Ironing	Hot ironing, max. 200°C 	Hot ironing, max. 150°C 	Hot ironing, max. 110°C 	Ironing not allowed 		
Drying	Dry flat (place on a flat surface) 	Drip dry  Line dry 	High temperature  Low temperature 	Do not tumble dry 		

STEP 2: PREPARING THE WASHING PROCESS

1. Sort the laundry by type of fabric, colour, soiling, appliance load, and allowed washing temperature (see PROGRAMME TABLE).
2. Close the buttons and zippers, tie any ribbons, and turn the pockets inside out; remove any metal clips that could damage the laundry and washer dryer interior, or clog the drain.
3. Place very sensitive clothes and small items in a special-purpose laundry washing bag.

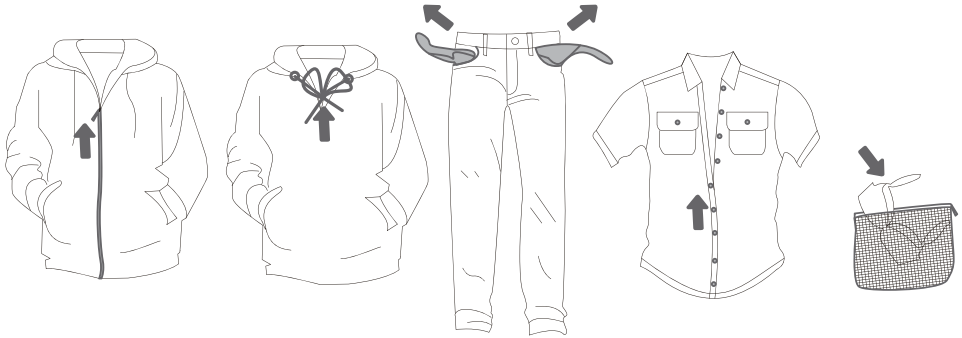

INSTRUCTIONS FOR AUTOMATIC SOAP DISPENSER

This product has an auto dosing feature to automatically add the right amount of detergent/softener to a wash. You can adjust the amount automatically dispensed by selecting little medium or large depending upon the strength of the washing needed. When the "Auto" option is selected, the washer dryer will intelligently judge the amount of detergent and softener according to the weight of the laundry. If you don't want to use the "Auto" option, please deselect it and add detergent and softener manually.

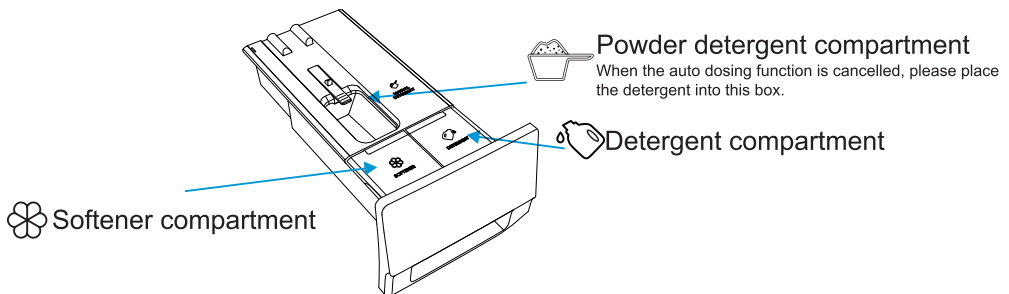

► ADDING OF DETERGENT/SOFTENER



► PREWASH

- When the auto-dosing function is turned on and the prewash function is selected, the amount of detergent in the prewash phase is half of that of the main wash phase.
- The amount of detergent in the pre-wash phase does not affect the detergent in the main wash phase.

► AUTO DOSING OPERATION STEPS

- When the washer dryer is used for the first time, the auto dosing function of both the detergent and softener is switched on by default. The washer dryer will remember the last chosen option when being started.
- To activate the function press the “Detergent” button. Press the detergent switch repeatedly to cycle through to the off position (not lit).
- When the icons  /  are light up, this indicates that the amount of detergent/softener is insufficient. Please top up as necessary. The maximum amount needed to fill the reservoirs is 1L of detergent or 0.5L of softener.

► PRECAUTIONS

1. It is recommended that you use low-foaming detergent
2. Please do not overfill the detergent/softener reservoirs as they may overflow
3. After filling, please ensure that the detergent drawer is fully closed before starting the washing program.
4. Please remove or secure the detergent drawer before installing, moving, handling, and adjusting the washer dryer. This is to avoid the inconvenience caused by an overflow of the detergent and softener.

► SOFTENER

Auto dosing

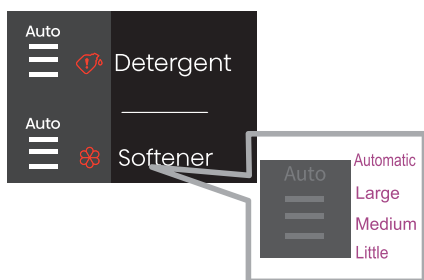

If the Auto icon is ON and all 3 lines are ON, it means that you have selected the automatic dosing function. The fabric softener is dosed automatically, depending on how much laundry is in the drum.

Manual dosing

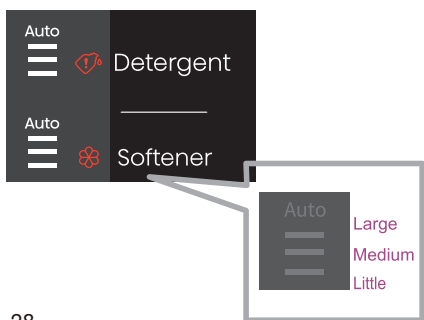

It is possible to manually select the desired amount of softener dosage. We can set the desired dosage value of the softener ourselves. There are three levels, little, medium and large. Manual dosing is selected when the Auto icon is not ON and lines can be selected (little, middle, large).

Softener OFF

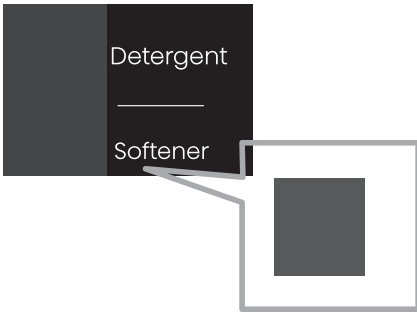

The softener is turned off and will not be dosed at the end of the program. This is visible on the display as in the picture below. No LED indications.

► DETERGENT

Auto dosing

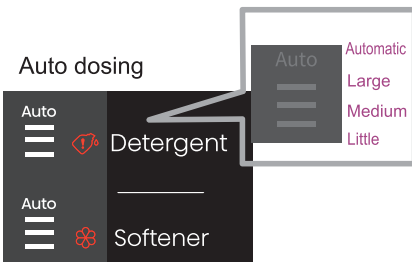

If the Auto icon is ON and all 3 lines are ON, it means that you have selected the automatic dosing function. The fabric detergent is dosed automatically, depending on how much laundry is in the drum.

Manual dosing

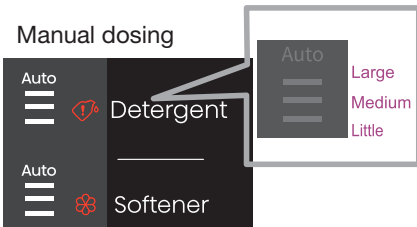

It is possible to manually select the desired amount of detergent dosage. We can set the desired dosage value of the detergent ourselves. There are three levels, little, medium and large. Manual dosing is selected when the Auto icon is not ON and lines can be selected (little, middle, large).

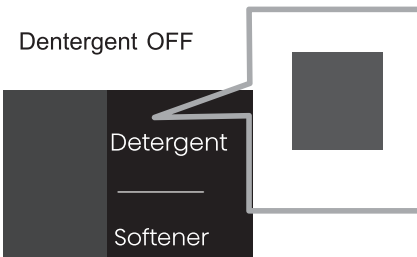

Detergent OFF



The detergent is turned off and will not be dosed at the end of the program. This is visible on the display as in the picture below. No LED indications.

► ADDING DETERGENT AND SOFTENER



If the display /  icons flash, it indicates that the amount of detergent/softener is insufficient. Please top up to a maximum of 1 L of detergent or 0.5L of softener.

► RE-ADDING OF DETERGENT/SOFTENER

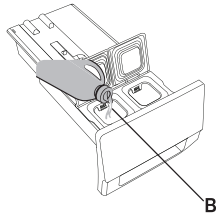
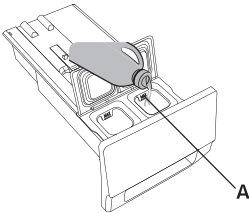

1. Slide to open the detergent drawer.
2. Add an appropriate amount of detergent to the automatic detergent compartment (A).
3. If necessary, add an appropriate amount of softener to the automatic softener compartment (B).
4. Close the auto dosing drawer.

SWITCHING ON THE WASHER DRYER

Use the power cord to connect the washer dryer to power mains, and connect the washer dryer to water supply.

Turn the appliance on by press the button "POWER" (figures 1 and 2).

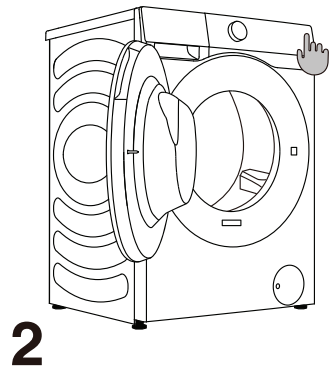
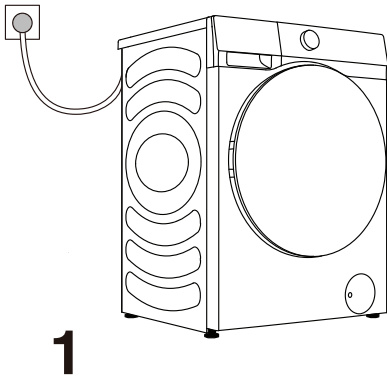

LOADING THE WASHER DRYER

Open the washer dryer door by pulling the handle towards you (figure 1).
Insert the laundry into the drum (after making sure the drum is empty) (figure 2).
Close the washer dryer door (figure 3). The door is closed when you here a click.

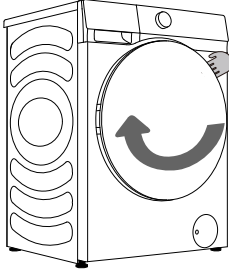

1

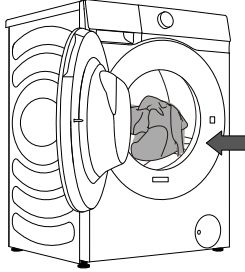

2

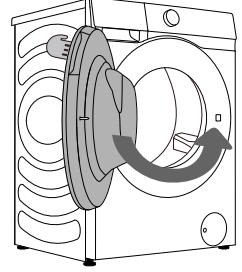

3

⚠ Never try to forcefully open the door. Moreover, do not open the door during washer dryer operation.

Do not overload the drum! See PROGRAMME TABLE and observe your nominal load as indicated on the rating plate.

If the washer dryer drum is too full, the laundry will not be washed as thoroughly.

STEP 3: CHOOSING THE WASHING PROGRAMME

Choose the **programme** by rotating the programme selector knob (1) to the left or to the right (depending on the type of laundry and how heavily soiled it is). See PROGRAMME TABLE.

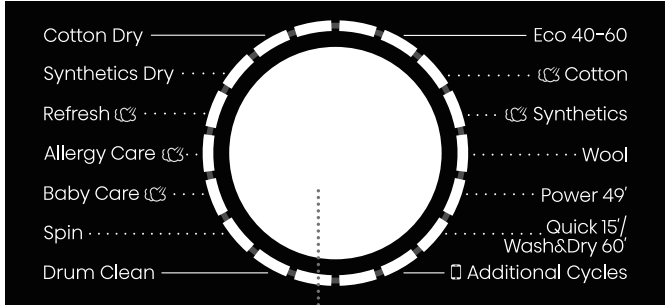

1

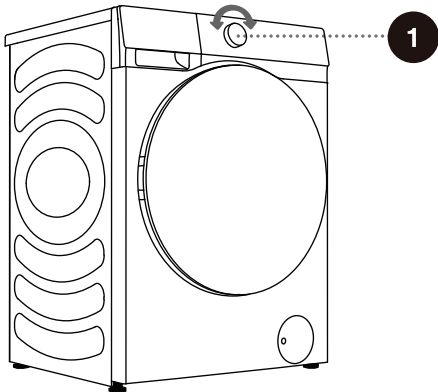

⚠ During operation, the programme selector knob (1) will not rotate automatically.

PROGRAMME TABLE

Programme	Max. load		Max spinning rate	Programme description
Eco40-60	10.5kg 6kg	12kg 8kg	1400 1400	Normally soiled cotton laundry.
Cotton (- -, 20°C, 30°C, 40°C, 60°C, 90°C)	10.5kg 6kg	12kg 8kg	1400 1400	Heavily and moderately soiled cotton, or linen. For very heavily soiled items select the "Prewash" function.
Synthetics (- -, 20°C, 30°C, 40°C, 60°C)	5kg 5kg	6kg 6kg	1400 1400	The program is suitable for moderately soiled synthetic and cotton fabrics.
Wool (- -, 20°C, 30°C, 40°C)	2kg		600	The program is suitable for machinewashable wool (see label on the garment).
Power 49' (- -, 20°C, 30°C, 40°C)	4kg		800	It is a short-time powerful washing procedure, which is used to wash a small amount of clothes with a high degree of dirt
Quick 15'/ Wash&Dry 60' (- -, 20°C, 30°C, 40°C)	1kg		800	Cotton, mixed fabrics. Items worn for a short time or newly bought. / The wash and dry process within 60 minutes is suitable for wash and dry the clothing with light dirty at once, such as the T-shirts, shirts and skirts that should be changed daily. It is recommended that no more than 3 pieces of skirts should be washed at a time. Select the function key "Dry Level" to complete the conversion of the two programs.
Drum Clean (self-cleaning programme) (90°C)	0kg		800	The program is used for cleaning the drum and removing any residues of detergent and bacteria that can accumulate and develop especially when you use programmes with low washing temperatures. The drum has to be empty. You can add some distilled (spirit) vinegar (approx. 2 dl) or sodium bicarbonate (1 tablespoon, or 15 g). Run this programme at least once a month.
Spin (spinning rate)	10.5kg 6kg	12kg 8kg	1400 1400	In this program, you can select the duration and spinning rate manually.

Programme	Max. load		Max spinning rate	Programme description
Baby Care (40°C, 60°C, 90°C)	2kg		1400	It is suitable for baby clothes and underwear, etc., which sterilizes and disinfects through high temperature steam
Allergy Care (40°C, 60°C, 90°C)	2kg		1400	It is suitable for high temperature resistant and less fading fabrics, which removes allergens such as pollens, mites and parasites through high temperature steam.
Refresh	2kg		/	It is suitable for removing the peculiar smell (such as, the smell of smoke/hot pot/barbecue, etc.) on the clothes.
Synthetics Dry	5kg	6kg	/	The wet chemical fiber clothes can be dried after being spun.
Cotton Dry	6kg	8kg	/	The wet cotton & linen clothes can be dried after being spun.
<input type="checkbox"/> Additional Cycles				
Rinse+Spin —	10kg	12kg	1400	This program is defaulted to two rinses and spin.
Shirts (- -, 20°C, 30°C, 40°C, 60°C)	2kg		800	This program is suitable for cotton clothes with light stains, energy saving.
Jeans (- -, 20°C, 30°C, 40°C, 60°C)	5kg	6kg	1400	The program is suitable for jeans.
Silk/Delicate (- -, 20°C, 30°C, 40°C)	2kg		600	Soft delicate fabrics and machine washable silk. (Refer to the washing label attached to the clothing).
Bedding (- -, 20°C, 30°C, 40°C, 60°C)	3kg		1400	Program adapted to wash large items - e.g. Curtains, sheets, duvet covers.
Mix (- -, 20°C, 30°C, 40°C)	5kg	6kg	1400	Mixed loads of moderately soiled cotton and synthetic fabrics.

CHOOSING THE DETERGENTS AND ADDITIVES

Always choose highly efficient detergents that do not foam and which are intended for front-loading appliances.

The choice of detergent depends on the type, soil level, laundry colour, and washing temperature.

☞ White residues (streaks etc.) on black laundry may appear if you are using modern phosphate-free detergents. In such case, brush the streaks and use a liquid detergent.

Only use detergent intended for appliances for household use.

Descaling agents may damage the appliance. Do not use solvents.

Do not wash the clothes that were cleaned with solvents or flammable substances.

Excessive amount of detergent may result in foaming that in turn impairs washing efficiency. If the appliance senses excessive foaming, it may prevent the spin cycle from taking place.

If the amount of detergent is too small, the laundry may no longer be white after a while. It could also result in accumulation of limescale in the drum and the pipes.

☞ Maximum amount of laundry for washing and drying, in kg (for the cotton programme), is indicated on the rating plate fitted under the appliance door.

☞ Maximum or nominal load applies to laundry prepared pursuant to the IEC 60456 standard.

☞ For better washing effect, we recommend loading the drum to 2/3 when using the cotton programmes.

STEP 4: SELECTING ADDITIONAL SETTINGS AND FUNCTIONS

Most programmes feature basic settings, but these settings can be changed.

Adjust the settings by pressing the relevant function button (before pressing the (8) START/PAUSE button).

☞ Activate/deactivate the functions by pressing the desired function (before pressing the (8) START/PAUSE button).

☞ Certain settings cannot be selected with some programmes. Such settings will not be lit, and when the corresponding button is pressed, an acoustic signal will be emitted and the button will flash (see FUNCTION TABLE).

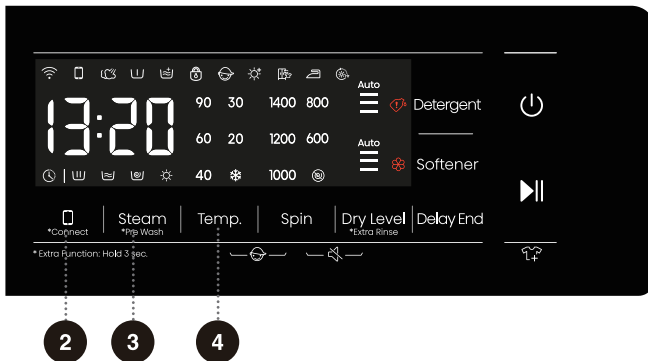

2

Connect

It is divided into two modes: "press and hold" and "press briefly".

Press briefly: start the remote control permission of the washing machine;

Press and hold: Connect the Wi-Fi of the washing machine, the control panel symbol "📶" flashes, and then conduct the networking operation. See the networking description for the specific networking method.

3

Steam, *Pre Wash

It is divided into two modes: "press and hold" and "press briefly".

Press briefly: Add "Steam" function, press twice to cancel the function, and cycle in sequence.

Press and hold: Increase the "Pre wash" function, press twice to cancel the function, and cycle in sequence.

1. Select this function to add a Pre Wash program before the Main Wash stage.
2. After the program is started, the indicator remains on until the end of Pre Wash program. After the end of Pre Wash, the indicator will off.

4

Temp. (WASHING TEMPERATURE)

Changing the temperature for the selected program.

Each program has a preset temperature that can be changed by pressing the position (4) **TEMP.** (WASHING TEMPERATURE).

(-- indicates cold wash)

The temperature is displayed on the display unit above the button.

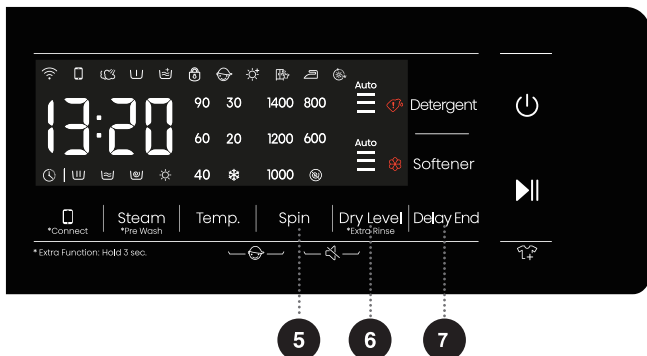

5 Spin (SPINNING RATE/DRAIN)

Use this to adjust the spinning rate. With preset or selected spinning rate, the selected spinning rate will be lit on the display unit. If you select draining without spinning, the 0 will appear on the display unit.

6 Dry Level *Extra Rinse

Press the "Dry Level" button to select the dry time and additional functions of dry.

EXTRA RINSE

Press to change the rinse count for current cycle.

7 Delay End

1. Press this key to set the Delay End time. This key is only valid in standby mode.

2. After the Delay End function is selected, each time the Delay End key is pressed, the time increases by 1h. If the programme time before the Delay End does not meet the integer multiple of 1h, then the first Delay End will make up the integer multiple of 1h. And after that, each time the Delay End key is pressed, the time increases by 1h. After the Delay End time is set up to 24h, the Delay End key can be pressed again to cancel this setting. If you turn the knob to select another programme or press other keys (including invalid keys, the principle is that any key that affects the washing process will cancel the Delay End program; however, Child Lock, Quiet, and remote control permission will not cancel the Delay End program) after the Delay End function is set and before the programme starts running, the current Delay End programme will be cancelled.

3. The Delay End time is the end time, that is, it includes the washing time, so the Delay End time must be greater than the washing time. For example, if the total time of the currently selected programme is 2:28, the selection range of Delay End time is 3-24 hours. That means, the display changes from 2:28 to 3:00, 4:00, ..., 9:00, h:10, ..., h:21 to h:24 in order. After the Delay End programme starts, the time display will change from h:24, h:23, ..., h:10, 9:59, 9:58, ..., until after the washing programme starts to run, at which time the display shows 2:28. This judgment condition also applies to the automatic weighing time function. When the display only shows the hour, the display shows the remaining time of the Delay End programme with the rounding method. (e.g. For 21:59, it still shows 21 hours.)

4. When the Delay End function is being selected (set), the Clock icon "🕒" is always on; When the Delay End programme is running, the Clock icon "🕒" flashes.

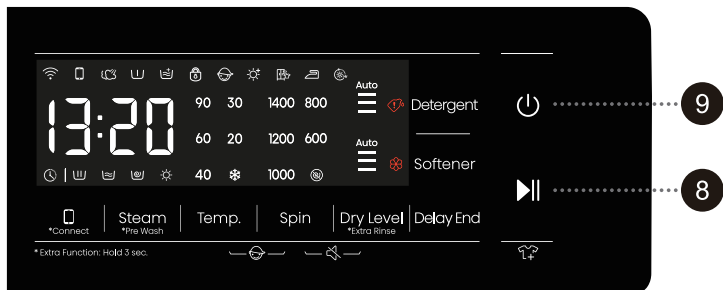

8 Start/Pause ▶||

- 1) Control the washer dryer from the standby state to the program running state, or from the program running state to the program pausing state.
- 2) Press the key in the standby mode to switch to door locking mode. If the door is unlocked, the washer dryer cannot start the program. At the same time, the door locking error alarm will occur.
- 3) After setting the Preset function, press this key in the standby state. If the door is normally locked, the washer dryer will switch to the Preset running state. If it is not locked, the washer dryer will switch to the abnormal state and the door locking error alarm will occur.
- 4) If the program is switched from the running state to the pausing state, the program will remain in the stopped position and wait for the user to press this key again to switch to the running state of the program. When the program switched from the Spin state to the program pausing state and then enters the program running state again, the program will start from the initial position of the Spin program.
- 5) Control the washer dryer to switch from abnormal state to program running state. This abnormal state applies only to alarm exceptions that can be canceled.
- 6) When the washer dryer is paused, the door will be unlocked automatically if the following conditions are met: 1. The water level is lower than the water level for opening the door; 2. The sensor temperature in the drum is lower than 50°C; 3. The motor speed is 0. If the unlocking conditions above are not met, there will be no action.
- 7) After starting the washer dryer, the set parameters can not be adjusted.

9 Power ⏻

- 1) Control the washer dryer to switch between "shutdown state" and "standby state". In the shutdown state, all display and output are turned off. The shutdown response time is 2s when the power key is pressed continuously.
- 2) Press the power key in the shutdown state, and the buzzer will sound to enter the standby state. The display's indications light up in turn as soon as the power is turned on.
- 3) Press the power key to start the machine and judge the door lock state:
- 4) After the washer dryer is in standby state or the END is displayed, the door will be unlocked, and press the power key to shut down. If there is no shutdown operation within 2 minutes, the washer dryer will automatically power off.
- 5) In the pausing state, the display time and colon on the LED flash at the same time.

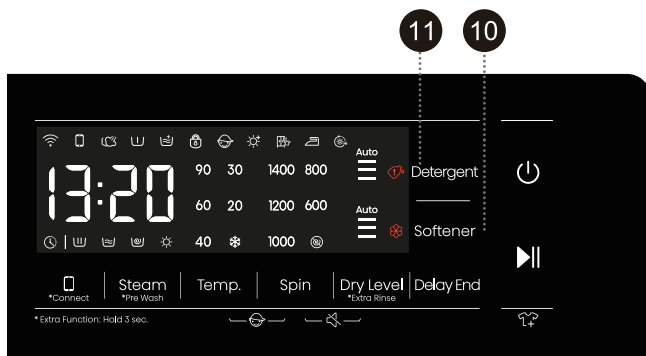

10

Softener

The automatic detergent dosage is enabled by default, and you can control the dosage by the button as needed; if you need to add detergent by yourself, you can disable the automatic detergent dosage.

11

Detergent

The automatic detergent dosage is enabled by default, and you can control the dosage by the button as needed; if you need to add detergent by yourself, you can disable the automatic detergent dosage.

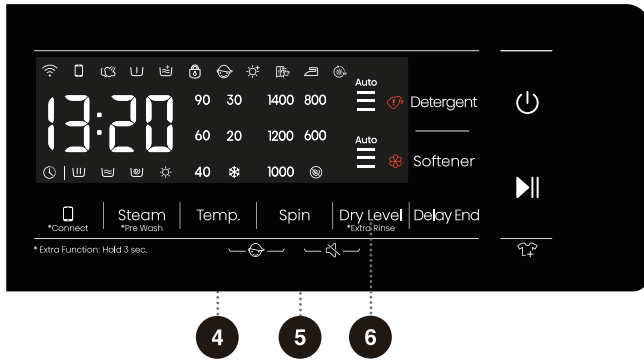

4 + 5

CHILD LOCK

This is a safety feature. To activate it, simultaneously press the positions (4)TEMP. (TEMPERATURE) and (5) SPIN, and hold them for at least 2 seconds. Child Lock icon will light up, and then Child Lock is set up. Repeat the same operation, the Child Lock will be released.

- When the Child Lock is set, all function buttons will be shielded.
- When you turn the machine off, child lock is released. After completing program, child lock will automatically unlock.



5 + 6

MUTE (SWITCHING OFF THE ACOUSTIC SIGNALS)

When the machine is in the state of holding, pause or operation, press " (5)Spin+ (6) Dry level " buttons for 2 seconds, The display will show mute function fault icon. All the buzzing will be turned off except the alarm s. When the machine is in the mute state, press " (5)Spin+ (6) Dry level " buttons for 2 seconds until mute function fault icon light off. All the buzzing will be activated.

FUNCTION TABLE

Programme	POWDER DETERGENT	DETERGENT	SOFTENER	Mute	Child Lock	Delay End	Spin	Temp.	Dry	Steam	Prewash	Extra rinse	Cupboard	Iron	Extra Dry	Time Dry
Eco40-60	•	•	•	•	•	•	•	-	•	-	-	-	•	•	•	•
Cotton	•	•	•	•	•	•	•	•	•	•	•	•	•	•	•	•
Synthetics	•	•	•	•	•	•	•	•	•	•	•	•	•	•	•	•
Wool	•	•	•	•	•	•	•	•	-	-	-	•	-	-	-	-
Power 49'	•	•	•	•	•	•	•	•	•	-	•	•	•	•	•	•
Quick 15/ Wash&Dry 60'	•	•	•	•	•	•	•	•	-	-	-	•	-	-	-	-
	•	•	•	•	•	•	-	-	•	-	-	-	-	-	-	•
Drum Clean (self-cleaning programme)	-	-	-	•	•	•	-	-	•	-	-	-	-	-	-	•
Spin (spinning rate)	-	-	-	•	•	•	•	-	•	-	-	-	•	•	•	•
Baby Care	•	•	•	•	•	•	•	•	•	•	•	•	•	•	•	•
Allergy Care	•	•	•	•	•	•	•	•	•	•	•	•	•	•	•	•
Refresh	-	-	-	•	•	•	-	-	•	•	-	-	-	-	-	•
Synthetics Dry	-	-	-	•	•	•	-	-	•	-	-	-	•	•	•	•
Cotton Dry	-	-	-	•	•	•	-	-	•	-	-	-	•	•	•	•
Rinse+Spin	-	-	•	•	•	•	•	-	•	-	-	•	•	•	•	•
Shirts	•	•	•	•	•	•	•	•	•	-	•	•	•	•	•	•
Jeans	•	•	•	•	•	•	•	•	•	-	•	•	•	•	•	•
Silk/Delicate	•	•	•	•	•	•	•	•	-	-	-	•	-	-	-	-
Bedding	•	•	•	•	•	•	•	•	•	-	•	•	•	•	•	•
Mix	•	•	•	•	•	•	•	•	•	•	•	•	•	•	•	•

- Optional functions
- Can not be selected

TIME OPTIMIZATION DURING THE PROGRAMME PROGRESS

In the early stage of the washing programme, the washer dryer uses advanced technology to detect the amount of laundry. After load detection, the washer dryer adjusts the programme duration.

STEP 5: STARTING THE WASHING PROGRAMME

Once you have selected the programme and extra functions, and added the detergent into the detergent compartment, press the (8) **START/PAUSE** button.

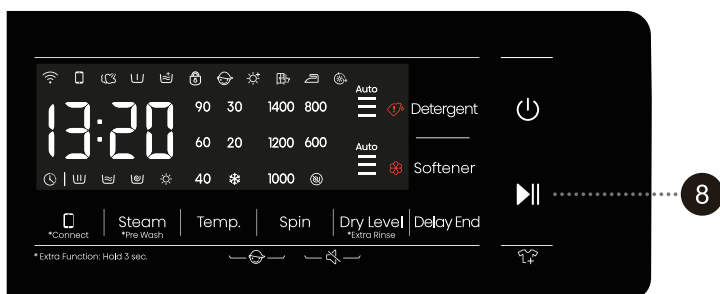



TIME REMAINING TO THE END OF THE PROGRAMME or **DELAY END** time (if set) will appear on the display.

Symbols will be lit on the selected functions.

When the program starts, "----" will appear on the display unit, which indicates that the laundry is being weighed. Program duration (hours : minutes) will be adjusted automatically according to the laundry weight.

After the start of the programme, Door Lock  will be lit on the display unit. When the program is complete, the icon will disappear.

If you press the (8) **START/PAUSE** button during program operation, and all conditions are met for you to open the door, then the  will disappear as well.

If the  flashes, this means that the door cannot be opened; in such case, do not attempt to open the door by force.

 If anything is flashing on the display unit, the washer dryer door is open or not closed correctly. Close the washer dryer door and press the (8) **START/PAUSE** button again to resume the washing programme.

STEP 6: CHANGE OF WASHING PROGRAMME OR MANUAL (PHYSICAL) CANCELLATION

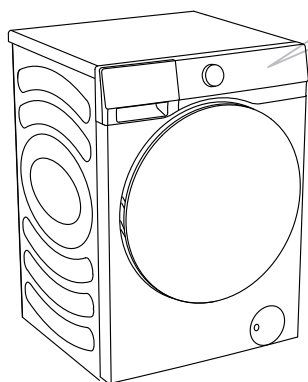

1 To stop and cancel a washing programme, press the button "POWER" for 3 seconds.

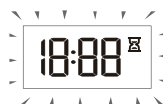

2 The washing programme is temporarily paused when the time remaining until programme completion is flashing on the display unit. At the same time, the washer dryer pumps the water out of the washer dryer drum. When the water is pumped out, washer dryer door will be unlocked. If the water in the washer dryer is hot, the washer dryer will automatically cool it and pump/drain it out.



3 To select a new programme, choose the programme by rotating the programme selector knob (1) and then select the programme and extra functions. Press the (8) START/PAUSE button, without adding the detergent again.

STEP 7: END OF THE WASHING PROGRAMME

An acoustic signal will indicate the end of the washing process; the display will read »End«. The appliance will switch off automatically if you do not perform any action within 2 minutes.



1. Open the washer dryer door.
2. Take the laundry from the drum.
3. Close the door!
4. Shut off the water supply tap.
5. Unplug the power cord from the outlet.

INTERRUPTIONS AND CHANGING THE PROGRAMME

MANUAL INTERRUPTION

To stop and cancel a washing programme, press the button "POWER" for 3 seconds.

PAUSE BUTTON

The washing programme can always be stopped by pressing the (8) **START/PAUSE** button. The washing programme is **temporarily paused** when the time remaining until programme completion is flashing on the display unit. If there is no water in the drum and water temperature is not too high, then the door will unlock, and they can be opened. To resume the washing program, first close the door and then press the key (8) **START/PAUSE** button.

ADDING/REMOVING LAUNDRY DURING WASHER DRYER OPERATION

After a certain period of time, the washer dryer door can be opened if the water level and temperature are below a predefined threshold.

If the conditions below are met, then the electronic door lock is released and the washer dryer door can be opened:

- water temperature in the drum has to be suitable,
- water level in the drum has to be below a certain value.

In order to add or remove laundry from the washer dryer during programme operation, proceed as follows:

1. Press the (8) **START/PAUSE** button.
2. If all conditions for release of electronic door lock are met, then you can open the washer dryer door and add or remove laundry from the drum.
3. Close the washer dryer door!
4. Press the (8) **START/PAUSE** button.

The washing program will resume.

⚠ If you add a considerable amount of laundry during the wash, the laundry could be washed less effectively, since the washer dryer initially sensed a lower weight of the load of laundry and added a smaller amount of water. Insufficient amount of water relative to the amount of laundry could also cause damage to the laundry (rubbing of dry laundry), and washing time can be longer.

⚠ Washing time will resume from the point at which the washing programme was interrupted.

ERRORS

In case of an error or fault, the programme will be interrupted.

Flashing signal lights and an acoustic signal will warn about such occurrence (see TROUBLESHOOTING TABLE), and the error will be indicated on the display (F:XX).

POWER SUPPLY FAILURE

In case of a power supply failure (power outage), the washing programme is interrupted. When power supply is restored, the program is resumed in the stage in which it was interrupted.

OPENING THE DOOR MANUALLY IN CASE OF A POWER OUTAGE - IN CASE OF A PROGRAM PAUSE

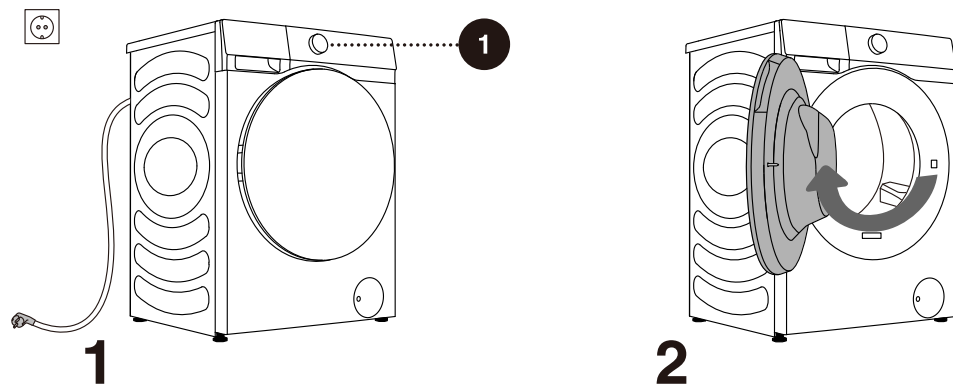

1 To stop and cancel a washing programme, press the button "POWER" for 3 seconds.

2 Open the washer dryer door manually by pulling the handle towards you.

OPENING THE DOOR (PAUSE/CANCEL – CHANGE PROGRAMME)

Washer dryer door can be opened if the water temperature is not excessively high. Otherwise, use manual (physical) interruption (see chapter INTERRUPTIONS AND CHANGING THE PROGRAMME/Manual (physical) interruption).

⚠ If there is still water in the washer dryer after a power outage, make sure not to open the door before you manually drain the water from the washer dryer via the pump filter.

EMERGENCY DOOR OPENING

In case of failure to open the door due to power outage or other special circumstances, the door lock lever at the drainage pump door can be used for emergency opening.

Note:

1. Do not operate when the machine is working normally;
2. Before operation, please make sure that the inner barrel has stopped turning, without high temperature, and the water level is lower than the clothing inlet. If the water level is higher than the clothing inlet, drain off water through the drain-away pipe (if available) or by slowly unscrewing the filter.

3. Operation method: Open the cover of drainage pump door, pull down the lock lever with the help of a tool, and then the door can be opened(indicated in the figure).

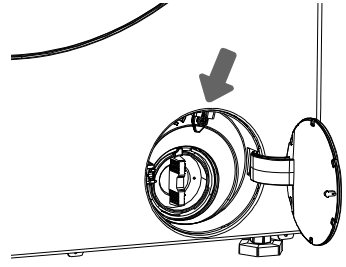

MAINTENANCE & CLEANING

⚠ Before cleaning, unplug the washer dryer from the power mains.

☹ Children should not clean the washer dryer or perform maintenance tasks without proper supervision!

CLEANING THE DETERGENT COMPARTMENT

☹ Detergent compartment should be cleaned at least twice per month.

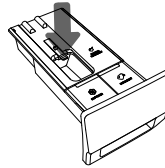
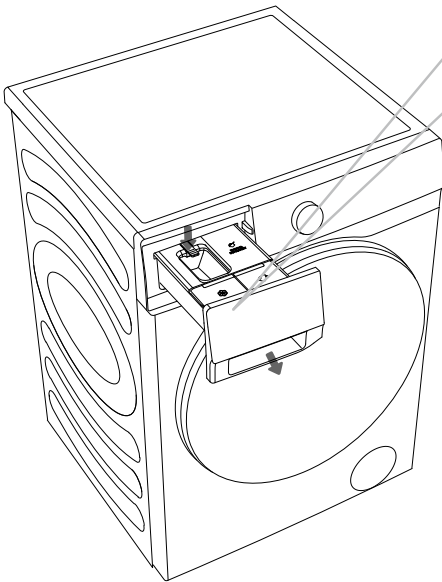

1 To remove the detergent compartment from the housing, press the small tab.

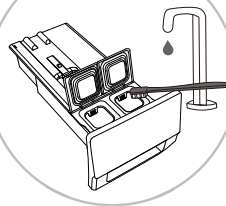

2 Clean the detergent compartment under running water using a brush, and dry it. Also, remove any detergent residue from the bottom of the housing. Remove the conditioner insert (softener insert) from the detergent compartment. Wash all parts under running water, and conditioner insert (softener insert) into detergent compartment and re-insert them into the detergent compartment housing.

☹ Do not wash the detergent compartment in a dishwasher.

CLEANING THE WATER SUPPLY HOSE, DETERGENT DISPENSER HOUSING, AND RUBBER DOOR GASKET

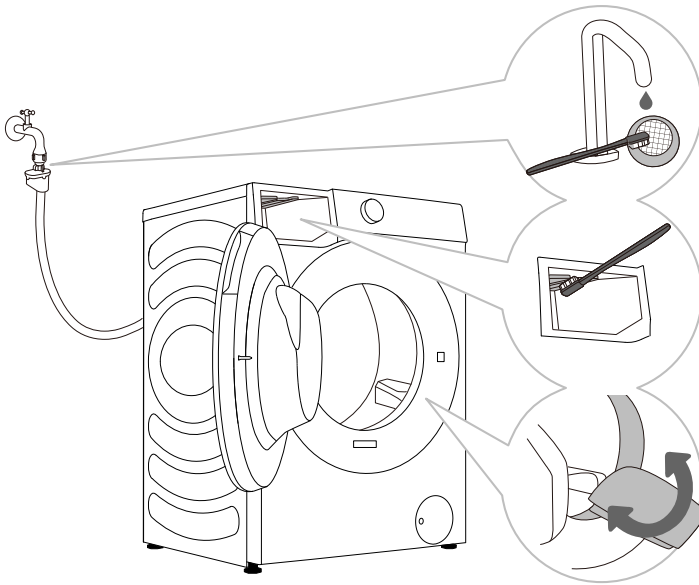

.....

1 Clean the net filter often under running water.

.....

2 Use a brush to clean the entire washer dryer rinsing section, especially the nozzles on the upper side of the rinsing chamber.

.....

3 After every wash, wipe the rubber door seal to extend its useful life.

.....

CLEANING THE PUMP FILTER

⚠ During cleaning, some water may be spilled. It is therefore recommended to place an absorbent cloth on the floor.

Make sure the water has cooled down before you release it from the appliance.

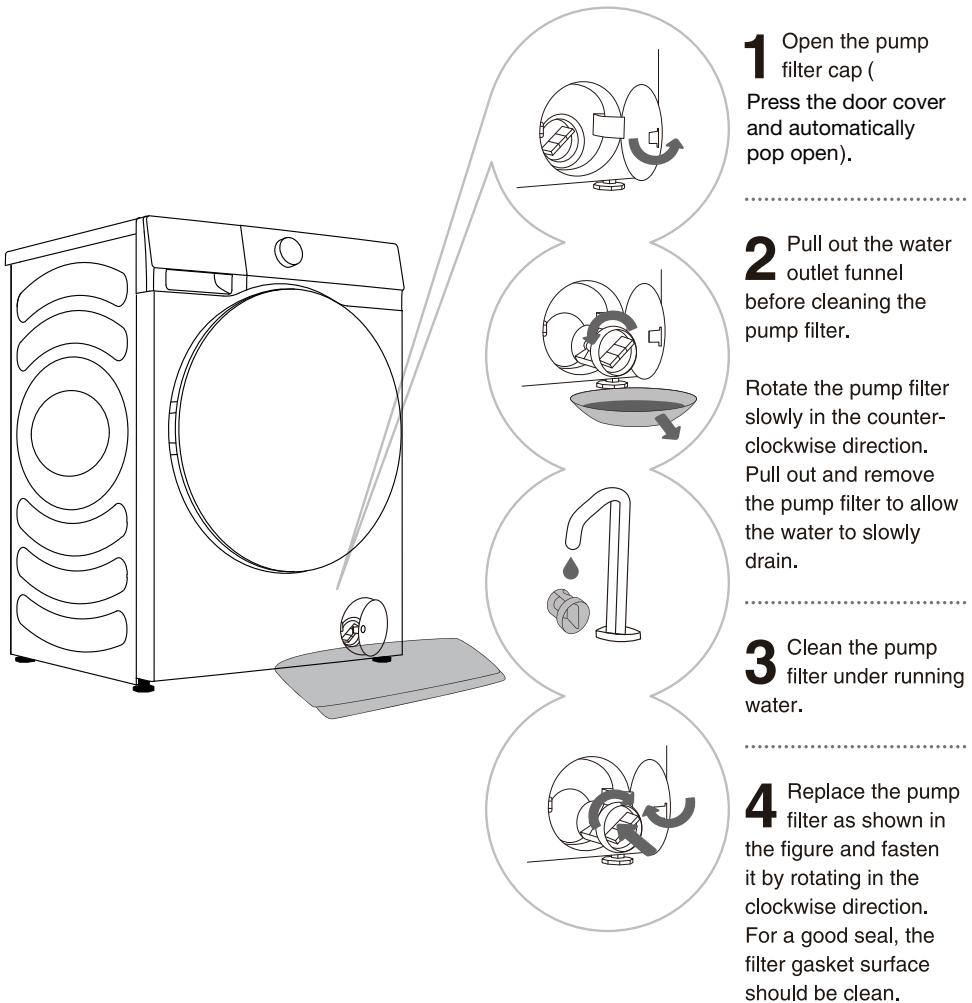

⚠ The pump filter must be occasionally cleaned, especially after washing very fleecy, woolly, or very old laundry.

⚠ Also clean the pump filter if the appliance cannot start the spinning cycle or when there is debris in the pump (buttons, coins, hair pins or clips etc.).

CLEANING THE WASHER DRYER EXTERIOR

⚠ Always disconnect the washer dryer from the power mains before cleaning.

Clean the washer dryer exterior and display unit using a soft damp cotton cloth and water. Then, use a soft dry cloth to dry the appliance.

⚠ Do not use any solvents, abrasive cleaners, or cleaning agents that could damage the appliance (please observe the recommendations and warnings provided by the cleaning agent).

If necessary, wipe the appliance door with a damp cloth, and then dry with a dry soft cloth as well.

⚡ Do not clean the washer dryer with a jet of water!

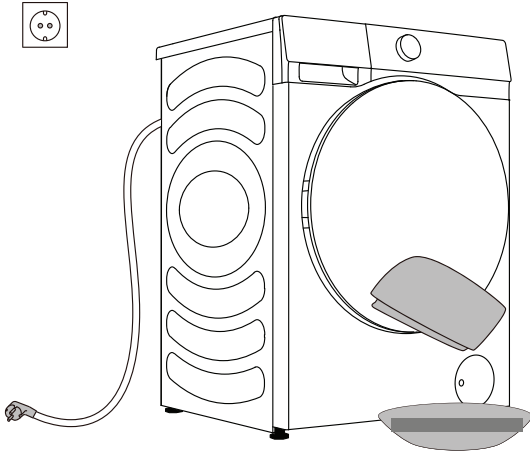

TROUBLESHOOTING

WHAT TO DO ...?

The washer dryer shall automatically control the operation of particular functions during the washing cycle. If any irregularity is identified, this will be indicated by reporting (F:XX) on the display. The washer dryer will report the error until it is switched off. Disturbances from the environment. (e.g. the power grid) may result in various error reports (see TROUBLESHOOTING TABLE). In such case:

- Switch off the washer dryer and wait for a few seconds.
- Switch on the washer dryer and repeat the washing programme.
- Most errors during operation can be resolved by the user (see TROUBLESHOOTING TABLE).
- If the error persists, call an authorized service unit.
- Repairs may only be carried out by an adequately trained person.
- Repair or any warranty claim resulting from incorrect connection or use of the washer dryer shall not be covered by the warranty. In such cases, the costs of repair shall be charged to the user.

⚡ The warranty does not cover the errors or failures resulting from disturbances from the environment (lightning strike, power grid failures, natural disasters etc.).

TROUBLESHOOTING AND ERROR TABLE

Problem/error	Indication on the display unit and problem description	What to do?
F01	Water inflow fault	Check the following: <ul style="list-style-type: none"> • Is the water supply tap open and is the pressure too low? • Is the water supply hose pinched? • Is the filter on the water supply hose clogged? • Is the hose frozen?
F03	Drainage fault	Check the following: <ul style="list-style-type: none"> • Is the hose pinched, does the water flow through it? • Is the filter on the drain hose clogged? • Is the hose frozen?
F04/F05/F06/ F07/F23	Electronic module fault	Switch off the appliance; Press the POWER for 3 seconds . Press the " start/pause " button again. If the error reoccurs, call a service technician.
F24	Water level reaches overflow level	Stop the programme by pressing the (8) START/ PAUSE button. Restart the programme. If the appliance continues to pump water into the tub, close the water tap and call a service technician
F13	Error while locking the door	Door is closed, but it cannot be locked. Switch off the washer dryer. Switch it back on and restart the washing programme. If the error reoccurs, call a service technician.
F14	Error while locking the door	Door is closed, but it cannot be unlocked. Turn off the appliance, then turn it back on. If the error reoccurs, call a service technician.
Unb	Unb Unbalance alarm	Unbalance alarm shall be solved by the following methods 1.Laundry winding Press the "Power" for 3 seconds for shutdown, open the door, shake the clothes and put them back into the washer dryer , then select the single dewatering program to dry again. 2.Too light-weighted laundry Press the"Power" for 3 seconds for shutdown, open the door, put in one or two towels, and then select the single dewatering program to dry again.
F15-F18	In case of abnormal drying	You can press and hold the "Power" button for 10s to shut down this machine, and restart this machine.

SERVICING

Before calling a service technician

When you contact a service centre, please state your washer dryer's type (1).

Type, code/ID, model, and serial number are indicated on the rating (type) plate located on the front side of the washer dryer door opening.

- ⚠ In case of a defect, only use approved spare parts by authorized manufacturers.
- ⚠ Repair or any warranty claim resulting from incorrect connection or use of the washer dryer shall not be covered by the warranty. In such cases, the costs of repair shall be charged to the user.

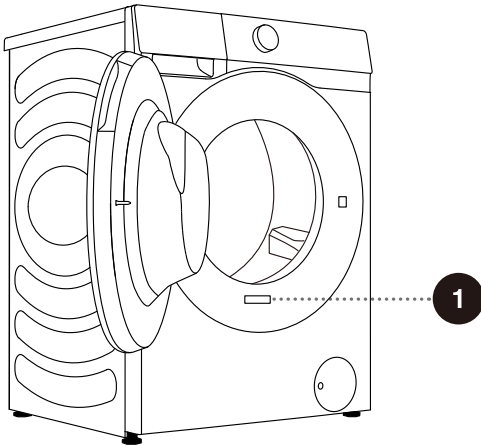

1

Hisense Washer-dryer
XXXXXXXXXX
XXX-XXXV~ XXHz IPX4
Washing Capacity:XX kg (XXXXW)
Drying Capacity:X kg (XXXXW)



RECOMMENDATIONS FOR WASHING AND ECONOMIC USE YOUR WASHER DRYER

Wash new coloured garments separately the first time.

Wash heavily soiled laundry in smaller amounts, with more powder detergent or with a pre-wash cycle.

Apply a special stain remover on stubborn stains before the wash. We recommend referring to STAIN REMOVAL TIPS.

If you often wash laundry at low temperatures and with liquid detergents, bacteria may spawn which can cause odour in the washer dryer. To prevent such odour, we recommend occasionally running the Drum Clean.

We recommend avoiding washing very small amounts of laundry as this will lead to excessive use of energy and poorer washer dryer performance.

Loosen any folded laundry before putting it into the drum.

Only use detergents for washer dryer.

If water hardness exceeds 14°dH, water softener should be used. Heater damage resulting from incorrect use of water softeners shall not be covered by the warranty. Check the information on water hardness with your local water supply company or authority.

Use of chlorine-based bleaches is not recommended as they can damage the heater.

If you use a descaling agent, bleach, or dye, only use the kind that is suitable for use in the appliance.

Do not use solvents or similar chemicals (e.g. paint thinner, turpentine, gasoline etc.)!

Do not add hardened lumps of powder detergent into the detergent dispenser as this may clog the piping in the washer dryer.

At higher spinning rates, there will be less residual moisture in the laundry. As a result, drying in a tumble dryer will be more economical and faster.

Water hardness	Hardness levels			
	°dH (°N)	m mol/l	°fH(°F)	p.p.m.
1 – soft	< 8,4	< 1,5	< 15	< 150
2 – normal	8,4 - 14	1,5 - 2,5	15 - 25	150 - 250
3 – hard	> 14	> 2,5	> 25	> 250

☼ Check the information on water hardness with your local water supply company or authority.

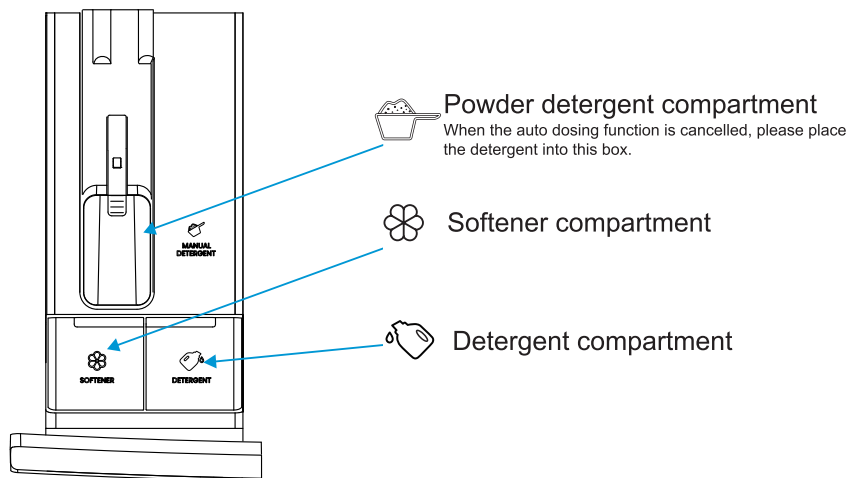

- ☼ Before the first use, don't exceed the MAX mark when adding detergent/softener to the automatic dosage port. You can select automatic dosage or manual addition of detergent.
- ☼ If you need to add washing powder manually, we recommend adding powder detergent immediately before the washing cycle. If you add it sooner, make sure the detergent compartment in the dispenser tray is completely dry before adding the powder detergent: otherwise, the powder detergent may cake before the start of the washing process.
- ☼ Do not add solid washing powder to the detergent/softener dosage port.
- ☼ Do not add detergent to the manual washing powder dosage port when using the automatic dosage function. If you need to add washing powder manually, please turn off the automatic dosage function first.

Keep detergents and additives out of reach of children.

STAIN REMOVAL TIPS

Before using special-purpose stain removers, try using the natural methods that do not harm the environment on less stubborn stains.

However, prompt action is required! Soak the stain with an absorbent sponge or a paper towel; then, rinse with cold (lukewarm) water – but never with hot water!

Stains	Stain removal
Mud	When the stain is dry, first scrape it off the garment before washing it in the washer dryer. If the stain is stubborn, soak it with an enzyme-based stain remover before the wash. If the stain is not stubborn, wash the laundry with liquid detergent or powder detergent and water before the wash.
Antiperspirant	Before washing in the washer dryer, apply liquid detergent onto the laundry. Apply stain removers on any stubborn stains. Alternatively, use oxygen-based bleach for the wash.
Tea	Soak or rinse the laundry in cold water and add stain remover if necessary.
Chocolate	Soak or rinse the laundry with lukewarm soapy water. Then, apply lemon juice and rinse.
Ink	Before washing in the washer dryer, apply stain removers on the stain. You may also use denatured alcohol. Turn the garment inside out and place a paper towel under the stain. Use the alcohol on the back side of the stain. At the end of the process, thoroughly rinse the garment.
Felt tip pens	Dilute some starch in water and apply it to the stain. When it dries, scrape it off with a brush; then, wash the garment in the washer dryer.
Baby food (urine, mud, food stains)	Before washing in the washer dryer, soak the stains in lukewarm water for at least half an hour. For easier stain removal, add an enzyme-based stain remover.
Grass	Before washing in the washer dryer, soak the laundry in an enzyme-based stain remover. Grass stains can also be removed by soaking (for approx. 1 hour) in diluted lemon juice or distilled vinegar.
Eggs	Soak the garment in an enzyme-based stain remover. Soak in cold water for at least 30 minutes or a few hours if the stains are stubborn. Then, wash in the washer dryer.
Coffee	Soak the garment in salt water. If the stain is not fresh, soak it with a mixture of glycerine, ammonia and alcohol.
Shoe polish	Apply cooking oil to the stain and rinse.

Stains	Stain removal
Blood	Fresh stain – rinse the garment with cool water and wash it in the washer dryer. Dried stain – soak the garment in an enzyme-based stain remover. Then, wash in the washer dryer. If the stain does not vanish, try to remove it with a bleach suitable for your garment.
Glue, chewing gum	Place the garment in a bag and put it in the freezer until the stain hardens. Then, remove it with a blunt knife. Then, dilute the stain with a prewash stain remover and rinse thoroughly. Then, wash the laundry as usual.
Makeup	Use a stain remover for the prewash; then, wash in the washer dryer.
Butter	Before washing in the washer dryer, apply stain remover to the stain. Then, rinse with hot water (as hot as the fabric will allow).
Milk	Soak the garment in an enzyme-based stain remover. Soak for at least 30 minutes or a few hours if the stains are stubborn. Then, wash in the washer dryer.
Fruit juice	Apply a mixture of salt and water on the stain. Leave to take effect for a while, then rinse. You can apply sodium bicarbonate, distilled vinegar or lemon juice on the stain before washing in the washer dryer. For old stains, use glycerine. After 20 minutes, rinse with cold water, then wash the laundry in the washer dryer.
Wine	Soak the laundry in cold water for at least 30 minutes. Also, use a stain remover. Then, wash in the washer dryer.
Wax	Put the garment into the freezer until the wax hardens. Then, scrape it off. Remove the remaining wax by placing a paper towel onto the stain, and then heat it with an iron until the paper absorbs the wax.
Sweat	Before washing in the washer dryer, rub liquid detergent thoroughly into the stain.
Chewing gum	Put the garment into the freezer until the chewing gum hardens. Then, scrape it off. Then, wash in the washer dryer.

DISPOSAL

Packaging is made of environmentally friendly materials that can be recycled, disposed of, or destroyed without any hazard to the environment. To this end, packaging materials are labelled appropriately.



The symbol on the product or its packaging indicates that the product should not be treated as normal household waste. Take the product to an authorized collection centre for waste electric and electronic equipment processing.

When **disposing** of the washer dryer at the end of its useful life, remove all power cords, and destroy the door latch and switch to prevent the door from locking or latching (child safety).

This appliance is marked according to the European directive on waste (WEEE).

Correct **disposal** of the product will help prevent any negative effects on the environment and health of people, which could occur in case of incorrect product removal. For detailed information on removal and processing of the product, please contact the relevant municipal body in charge of waste management, your waste disposal service, or the store where you bought the product.

TYPICAL CONSUMPTION TABLE

Programme Instructions

1. The eco 40-60 programme is able to clean normally soiled cotton laundry declared to be washable about 40 °C to 60°C, together in the same cycle, and that this programme is used to assess the compliance with the EU ecodesign legislation.
 2. The power consumption of the off-mode is 0.49W.
 3. The most efficient programmes in terms of energy consumption are generally those that perform at lower temperatures and longer duration.
 4. Loading the household washer dryer up to the capacity indicated by the manufacturer for the respective programmes will contribute to energy and water savings.
 5. Correct use of detergent, softeners and other additives. Do not apply excessive detergent. This may affect the washing results adversely.
 6. Periodic cleaning, including optimal frequency, and limescale prevention and procedure.
 7. Noise and remaining moisture content are influenced by the spinning speed: the higher the spinning speed in the spinning phase, the higher the noise and the lower the remaining moisture content.
 8. The product information and QR code are reflected in the energy consumption label, the product registration information can be obtained by scanning the QR code.
 9. The information of standard programmes.
-

Model	Program	Selected Temperature (°C)	Rated Capacity (kg)	Maximum temperature in drum (°C)	Program duration (h:min)	Energy consumption kWh/cycle	Water consumption litres/cycle	Remaining moisture content (%)	Maximum speed reached rpm
WD5S1045BW WD5S1045B*	Eco 40-60 full load	-	10.5	41	3:59	1.044	58.0	51.00	1400
	Eco 40-60 half load	-	5.25	30	3:00	0.507	42.0	53.50	1400
	Eco 40-60 1/4 load	-	2.5	23	2:40	0.213	30.0	53.00	1400
	Wash and Dry full load	-	6	27	7:59	3.706	102.0	--	1400
	Wash and Dry half load	-	3	23	5:09	2.075	70.0	--	1400
	Cotton	20°C	10.5	20	2:09	0.200	85.0	51.00	1400
	Cotton	60°C	10.5	55	3:29	1.600	110.0	53.00	1400
	Synthetics	40°C	5	40	1:58	0.880	69.0	45.00	1400
	Quick 15'	20°C	1	20	0:15	0.050	22.0	55.00	800

The values given for programmes other than the eco 40-60 programme and the wash and dry cycle are indicative only.

The entry mode of wash and dry cycle is to select the eco 40-60 programme, and press the dry level button once.

LOW STANDBY MODE

☼ Maximum or nominal load applies to laundry prepared pursuant to the IEC 60456 standard.

⚠ Due to deviations in terms of type and amount of laundry, spinning, power supply oscillation, and environment temperature and humidity, the programme duration and power consumption values measured at the end user may differ from the ones stated in the table.

We reserve the right to any changes and errors in the instructions for use.

Wi-Fi CONNECTION

Enter the "Settings" interface on your smartphone or tablet PC, enable the Bluetooth and Wireless Connection, and connect to the wireless network.

NOTE

This device can support the 2.4 GHz Wi-Fi.

Download

In the APP Store (Google Play Store, Apple App Store) on your smartphone or tablet PC, find the ConnectLife app, download and install it.

NOTE

In order to improve performance and experience, the application may be updated without notification.

Log in

You need to log in to ConnectLife with your account first. If you do not have a ConnectLife account, you will need to create a new one. Please refer to the App Instructions for details.

NOTE

If you already have a Google account, you can use your Google account to log in directly.



Device Binding

1. Open ConnectLife on your smartphone or tablet PC;
2. Bind your device on ConnectLife as follows:
 - A. Click "Start here Add appliances" in "Home" page, or click "Add appliances" in "Devices" page, or click "+".
 - B. Select "Washing Machine" or click "Scan QR/BAR code" or "Manual entry" below.
 - C. Scan the QR/BAR code on the device or enter the AUID/SN manually. If you can not find it, click (?) for instructions.
 - D. Click "SET UP APPLICATION"
 - E. Read the instructions, operate the device into the Networking and Binding state, and click "NEXT".
 - F. At this time, the app starts to search for devices, and you can select the device to be connected to the network from the search list; If it is not found, check your bluetooth whether turn on. Bluetooth should be keep it on at all time. And then click "NEXT".
 - G. Select your home Wi-Fi, enter the password, Then click the "CONNECT". The appliance will start networking and binding.
 - H. After binding successfully, you can set the device name and room.
 - I. Now, the device can be control remotely by APP.

NOTE

How to reset Wi-Fi and unbind all the binding relationship of the device:

1. Press the power key to start the device and make it connect to the network normally.
2. Press the last two keys simultaneously for 3 seconds, and the screen will display "c-b".
3. Shut down and restart the device to make a new binding.
4. After unbinding, the device must be restarted, or the unbinding will fail. Unbinding will delete users information stored in appliance before.
5. How to exit the network distribution mode:

If you want to quit when screen display "b00n", press  "simultaneously for 3 seconds, you can turn off the appliance by press  or wait for 5 minutes.

Hisense

life reimagined