

Cooker hood
油烟机

gorenje

BY

S+ARCK®

S3 WHT961STX
S3 WHT941ST

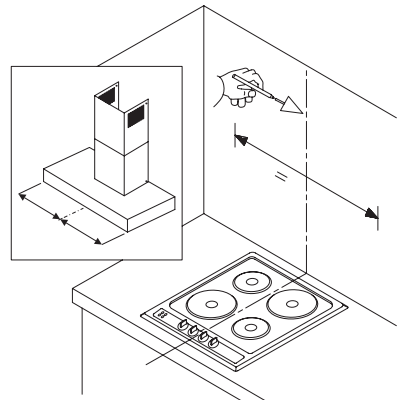
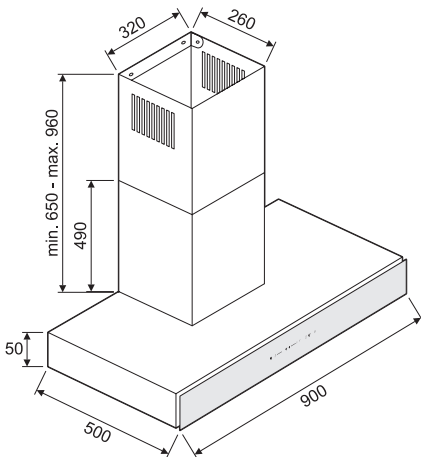
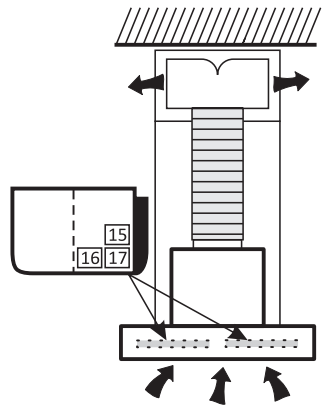
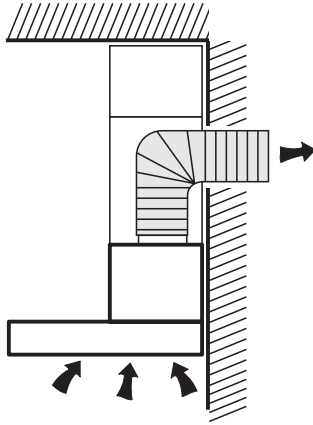
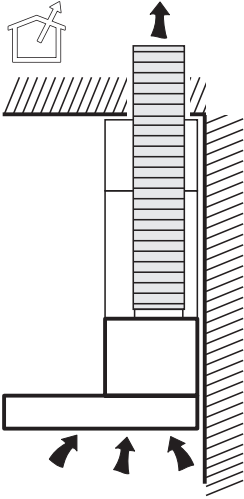
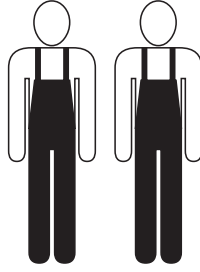

1

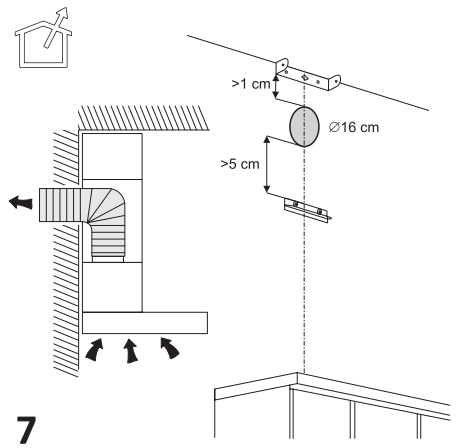
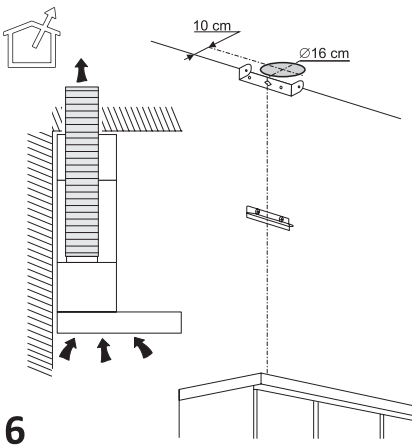
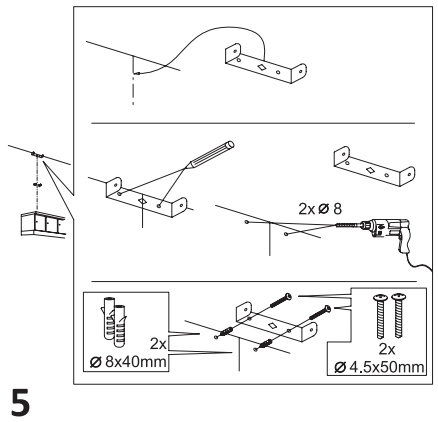
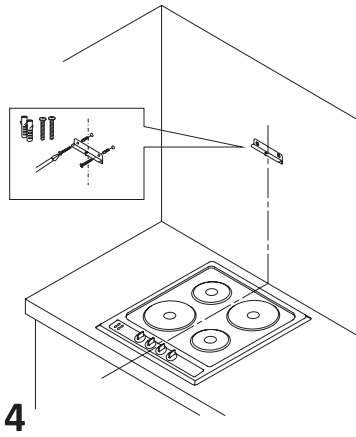
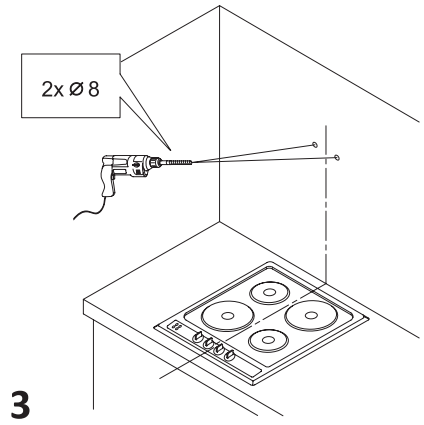
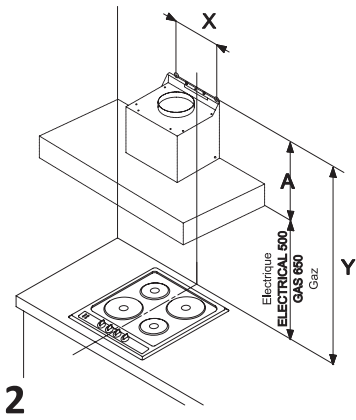

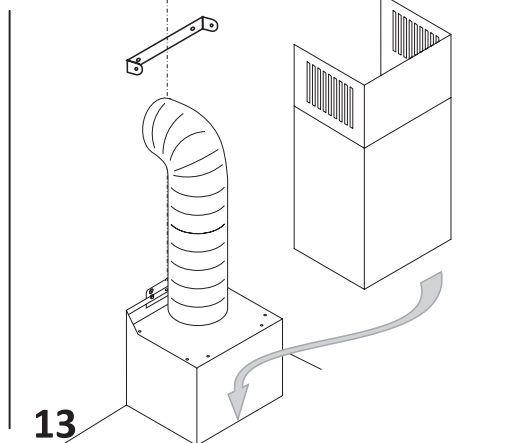
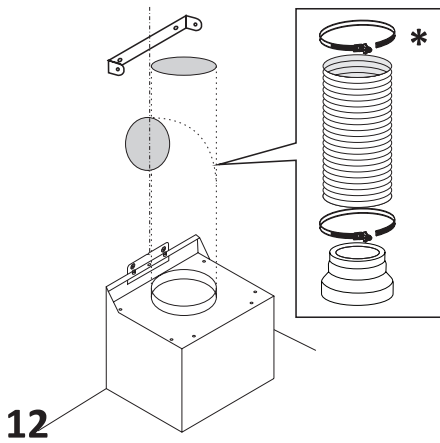
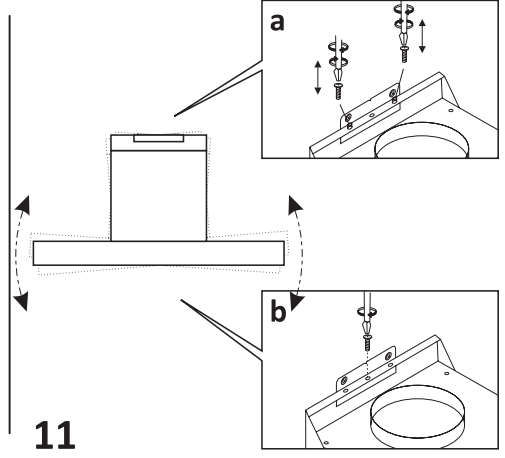
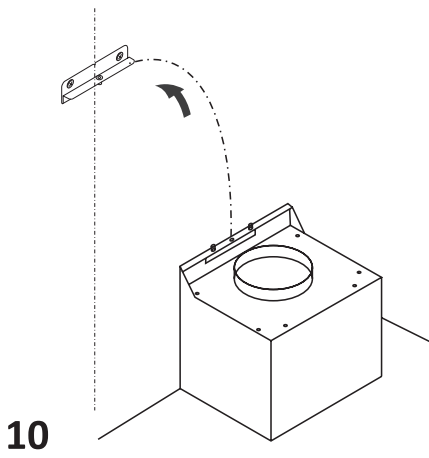
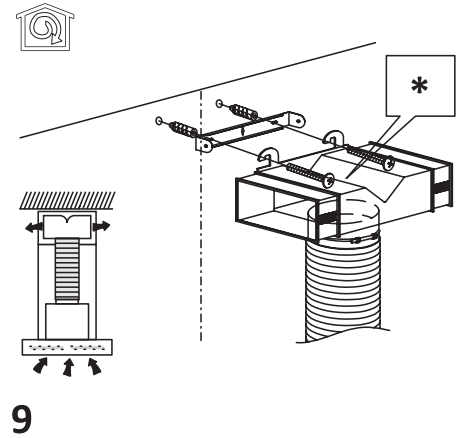
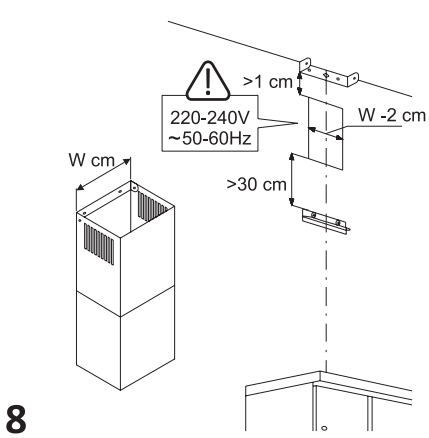

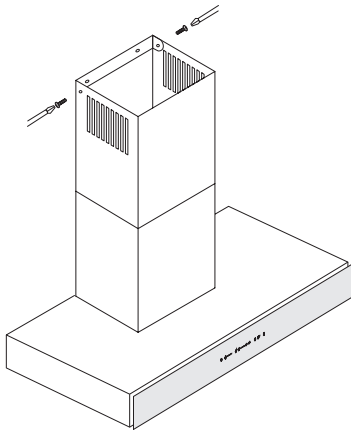

14

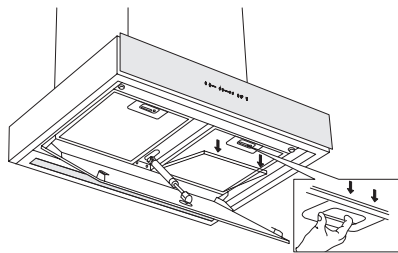

15

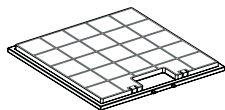
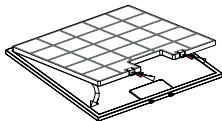
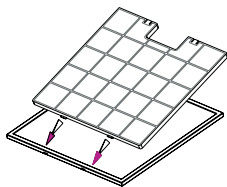

16

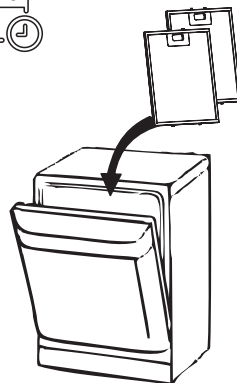

17

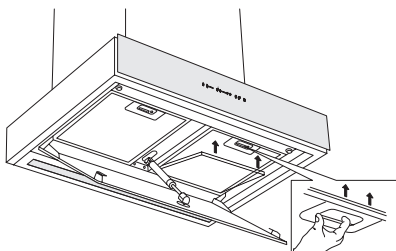

18

Closely follow the instructions set out in this manual. All responsibility, for any eventual inconveniences, damages or fires caused by not complying with the instructions in this manual, is declined. The hood is conceived for the suction of cooking fumes and steam and is destined only for domestic use.

The hood can look different to that illustrated in the drawings in this booklet. The instructions for use, maintenance and installation, however, remain the same.

! It is important to conserve this booklet for consultation at any moment. In the case of sale, cession or move, make sure it is together with the product.

! Read the instructions carefully: there is important information about installation, use and safety.

! Do not carry out electrical or mechanical variations on the product or on the discharge conduits.

! Before proceeding with the installation of the appliance verify that there are no damaged all components. Otherwise contact your dealer and do not proceed with the installation.

Note: the elements marked with the symbol “(*)” are optional accessories supplied only with some models or elements to purchase, not supplied.



CAUTION WARNING!

! Do not connect the appliance to the mains until the installation is fully complete.

! Before any cleaning or maintenance operation, disconnect hood from the mains by removing the plug or disconnecting the mains electrical supply.

! Always wear work gloves for all installation and maintenance operations.

! The appliance is not intended for use by children or persons with impaired physical, sensorial or mental faculties, or if lacking in experience or knowledge, unless they are under supervision or have been trained in the use of the appliance by a person responsible for their safety.

! This appliance is designed to be operated by adults, children should be monitored to ensure that they do not play with the appliance.

! This appliance is designed to be operated by adults. Children should not be allowed to tamper with the controls or play with the appliance.

! Never use the hood without effectively mounted grating!

! The hood must NEVER be used as a support surface unless specifically indicated.

! The premises where the appliance is installed must be sufficiently ventilated, when the kitchen hood is used together with other gas combustion devices or other fuels.

! The ducting system for this appliance must not be connected to any existing ventilation system which is being used for any other purpose such as discharging exhaust fumes from appliances burning gas or other fuels.

! The flaming of foods beneath the hood itself is severely prohibited.

! The use of exposed flames is detrimental to the filters and may cause a fire risk, and must therefore be avoided in all circumstances.

! Any frying must be done with care in order to make sure that the oil does not overheat and ignite. Accessible parts of the hood may become hot when used with cooking appliance.

! With regards to the technical and safety measures to be adopted for fume discharging it is important to closely follow the regulations provided by the local authorities.

! The hood must be regularly cleaned on both the inside and outside (AT LEAST ONCE A MONTH).

! This must be completed in accordance with the maintenance instructions provided in this manual). Failure to follow the instructions provided in this user guide regarding the cleaning of the hood and filters will lead to the risk of fires.

! Do not use or leave the hood without the lamp correctly mounted due to the possible risk of electric shocks.

! We will not accept any responsibility for any faults, damage or fires caused to the appliance as a result of the non-observance of the instructions included in this manual.

! This appliance is marked according to the European directive 2002/96/EC on Waste Electrical and Electronic Equipment (WEEE). By ensuring this product is disposed of correctly, you will help prevent potential negative consequences for the environment and human health, which could otherwise be caused by inappropriate waste handling of this product.



The symbol  on the product, or on the documents accompanying the product, indicates that this appliance may not be treated as household waste. Instead it should be taken to the appropriate collection point for the recycling of electrical and electronic equipment. Disposal must be carried out in accordance with local environmental regulations for waste disposal.

For further detailed information regarding the process, collection and recycling of this product, please contact the appropriate department of your local authorities or the local department for household waste or the shop where you purchased this product.

Appliance designed, tested and manufactured according to:

- Safety: EN/IEC 60335-1; EN/IEC 60335-2-31, EN/IEC 62233.
- Performance: EN/IEC 61591; ISO 5167-1; ISO 5167-3; ISO 5168; EN/IEC 60704-1; EN/IEC 60704-2-13; ISO 3741; EN 50564; IEC 62301.
- EMC: EN 55014-1; CISPR 14-1; EN 55014-2; CISPR 14-2; EN/IEC 61000-3-2; EN/IEC 61000-3-3.

Suggestions for a correct use in order to reduce the environmental impact: Switch ON the hood at minimum speed when you start cooking and kept it running for few minutes after cooking is finished. Increase the speed only in case of large amount of smoke and vapour and use boost speed(s) only in extreme situations. Replace the charcoal filter(s) when necessary to maintain a good odour reduction efficiency. Clean the grease filter(s) when necessary to maintain a good grease filter efficiency. Use the maximum diameter of the ducting system indicated in this manual to optimize efficiency and minimize noise.

Additional Installation Specifications:

Use only the fixing screws supplied with the product for installation or, if not supplied, purchase the correct screws type. Use the correct length for the screws which are identified in the Installation Guide.

In case of doubt, consult an authorised service assistance centre or similar qualified person.

WARNING! Failure to install the screws or fixing device in accordance with these instructions may result in electrical hazards.

USE

The hood is designed to be used either for exhausting or filter version.



Ducting version

In this case the fumes are conveyed outside of the building by means of a special pipe connected with the connection ring located on top of the hood.

Attention! The exhausting pipe is not supplied and must be purchased apart. Diameter of the exhausting pipe must be equal to that of the connection ring.

In the horizontal runs the exhausting pipe must be slightly slanted (about 10°) and directed upwards to vent the air easily from the room to the outside.

Attention! If the hood is supplied with active charcoal filter, then it must be removed.

Connect the hood and discharge holes on the walls with a diameter equivalent to the air outlet (connection flange).

Using the tubes and discharge holes on walls with smaller dimensions will cause a diminution of the suction performance and a drastic increase in noise.

Any responsibility in the matter is therefore declined.

- ! Use a duct of the minimum indispensable length.
- ! Use a duct with as few elbows as possible (maximum elbow angle: 90°).
- ! Avoid drastic changes in the duct cross-section.
- ! Use a duct as smooth as possible inside.
- ! The duct must be made of certified material.



Filter version

One active charcoal filter is needed for this and can be obtained from your usual retailer.

The filter removes the grease and smells from the extracted air before sending it back into the room through the upper outlet grid.

INSTALLATION

The minimum distance between the supporting surface for the cooking equipment on the hob and the lowest part of the range hood must be not less than 50cm from electric cookers and 65cm from gas or mixed cookers.

If the instructions for installation for the gas hob specify a greater distance, this must be adhered to.



Electrical connection

The mains power supply must correspond to the rating indicated on the plate situated inside the hood. If provided with a plug connect the hood to a socket in compliance with current regulations and positioned in an accessible area, after installation. If it not fitted with a plug (direct mains connection) or if the plug is not located in an accessible area, after installation, apply a double pole switch in accordance with standards which assures the complete disconnection of the mains under conditions relating to over-current category III, in accordance with installation instructions.

Warning! Before re-connecting the hood circuit to the mains supply and checking the efficient function, always check that the mains cable is correctly assembled.

The hood is provided with a special power cable ; if the cable is damaged, request a new one from Technical Service.

Mounting

Very heavy product; hood handling and installation must be carried out by at least two persons. Before beginning installation:

- Check that the product purchased is of a suitable size for the chosen installation area.
- Remove the charcoal (*) filter/s if supplied (see also relative paragraph). This/these is/are to be mounted only if you want to use the hood in the filtering version.
- Check (for transport reasons) that there is no other supplied material inside the hood (e.g. packets with screws (*), guarantees (*), etc.), eventually removing them and keeping them.
- If possible, disconnect and move freestanding or slide-in range from cabinet opening to provide easier access to rear wall/ceiling. Otherwise put a thick, protective covering over countertop, cooktop or range to protect from damage and debris. Select a flat surface for assembling the unit. Cover that surface with a protective covering and place all canopy hood parts and hardware in it.
- In addition check whether near the installation area of the hood (in the area accessible also with the hood mounted) an electric socket is available and it is possible to connect a fumes discharge device to the outside (only suction version).
- Carry out all the masonry work necessary (e.g. installation of an electric socket and/or a hole for the passage of the discharge tube).

Expansion wall plugs are provided to secure the hood to most types of walls/ceilings. However, a qualified technician must verify suitability of the materials in accordance with the type of wall/ceiling. The wall/ceiling must be strong enough to take the weight of the hood. Do not tile, grout or silicone this appliance to the wall. Surface mounting only.

OPERATION

Use the high suction speed in cases of concentrated kitchen vapours. It is recommended that the cooker hood suction is switched on for 5 minutes prior to cooking and to leave in operation during cooking and for another 15 minutes approximately after terminating cooking.



To select the functions of the hood, simply touch the controls.

T1. Standby mode (the control panel off all functions disabled) / **ON** (control panel switched on)

Note: After about a minute of inactivity (suction and lights), the hood will automatically switch to standby.

T2. ON/OFF lights

On certain models only (**see drawing above**):

press repeatedly to select the desired light intensity:

L1: low light

L2: medium light

L3: high light

Press again to turn off the lights.

T3. ON/OFF Automatic operation

The hood automatically sets the suction speed (power) 1 to increase if the environmental conditions detected by the hood sensor require it.

If there are no variations in the environmental conditions, after 10 minutes (if the hood is already in suction speed (power) 1), the hood turns off.

Note: for a correct use of this function, first perform the "Setting of the parameters for Automatic Operation" (see corresponding paragraph).

Note: During automatic operation, if the user acts on the other functions that adjust the speed, auto ventilation function is switched off.

T4. Manual selection of the suction speed (power):

L4: suction speed (power) 1

L5: suction speed (power) 2

L6: suction speed (power) 3

Press again to turn off the hood (OFF).

Note: manual selection excludes any other suction related set function.

T5. ON/OFF Intensive suction speed (power) „POWER BOOST” (timed)

Note: After 5 minutes of operation the hood returns to its previous state.

T6*. (Only certain models ON/OFF intensive suction speed (power) „POWER BOOST x 2” (timed)

Note: After 5 minutes of operation, the hood goes back to the previous status.

T7. ON/OFF operation mode “Air refresh”

Every 50 minutes of inactivity, the suction speed (power 1 is turned on for 10 minutes.

T8. ON/OFF Delayed switch off of the suction speed (power) (approx. 30 minutes)

Note: this function is available for the speeds that can be selected with button **T4**.

T9. Indicator and reset filter saturation

The button lights on automatically with steady light when it is necessary to perform the grease filter maintenance. The button lights on automatically with flashing light when it is necessary to perform the charcoal filter maintenance.

After performing the maintenance, with the hood off and the button active, press the button for more than 3 seconds to perform the reset of the filter saturation indicator; repeat the operation if necessary (for ex., when both filters are

saturated).

Activation of the charcoal filter saturation indicator

The saturation indicator of the charcoal filter is normally disabled. To activate it, proceed in the following manner: With the display on (ON) and the suction off (OFF), press simultaneously the buttons **T8** and **T9** for more than 3 seconds; the button **T9** lights on with steady light for approx. 5 seconds, to indicate the activation. To disable it, repeat the operation; the button **T9** will flash for approx. 5 seconds to indicate the disabling.

Setting of Automatic Operation parameters

For correct use of the automatic operation, perform "Hood Calibration".

Hood Calibration

With the display on (ON) and the suction off (OFF), press button **T3** for 3 seconds.

The suction speed (power) 1 starts functioning and button **T3** flashes to indicate that hood calibration is initiated and it will last for approx. 5 minutes.

Note: to interrupt the calibration, press **T3** for 5 seconds; the calibration will be invalidated and should therefore be repeated.

MAINTENANCE

ATTENTION! Before performing any maintenance operation, isolate the hood from the electrical supply by switching off at the connector and removing the connector fuse.

Or if the appliance has been connected through a plug and socket, then the plug must be removed from the socket.

Cleaning

The cooker hood should be cleaned regularly (at least with the same frequency with which you carry out maintenance of the fat filters) internally and externally. Clean using the cloth dampened with neutral liquid detergent. Do not use abrasive products. **DO NOT USE ALCOHOL!**

WARNING: Failure to carry out the basic cleaning recommendations of the cooker hood and replacement of the filters may cause fire risks. Therefore, we recommend observing these instructions. The manufacturer declines all responsibility for any damage to the motor or any fire damage linked to inappropriate maintenance or failure to observe the above safety recommendations.

Grease filter

Traps cooking grease particles. The grease filter must be cleaned once a month using non aggressive detergents, either by hand or in the dishwasher, which must be set to a low temperature and a short cycle. When washed in a dishwasher, the grease filter may discolour slightly, but this does not affect its filtering capacity. To remove the grease filter, pull the spring release handle.

Charcoal filter (filter version only)

It absorbs unpleasant odours caused by cooking. The saturation of the charcoal filter occurs after more or less prolonged use, depending on the type of cooking and the regularity of cleaning of the grease filter. In any case it is necessary to replace the cartridge at least every four months. The charcoal filter may NOT be washed or regenerated.

Replacing lamps

The hood is equipped with a lighting system based on LED technology. The LEDs guarantee an optimum lighting, a duration up to 10 times as long as the traditional lamps and allow to save 90% electrical energy.

For replacement, contact the technical service.

ZH - 油烟机

请务必按照用户手册的指示操作。任何没有按照用户手册指示操作所导致的机器损坏、使用不当和火灾发生的所有责任都不在保修范围之内。油烟机只用于家庭吸油烟和蒸汽使用。

油烟机在手册中描述不完全相同。使用、维护和安装指南保持一致。

! 请妥善保存用户使用手册。无论是在售卖、转让和搬家的时候请确保手册和机器保存在一起。

! 请仔细阅读手册内容: 有关安装、使用和安全性的的重要信息。

! 不要改动机器的电子、机械或者排气管的构造。

! 安装操作机器之前请查实确保所有的元器件没有损坏。如有发现损坏, 停止安装和使用并联系经销商。

注意: 标示为“(*)”的配件为可选备件, 只有一些型号提供, 如需要该元器件, 需要购买。



注意 警告!

! 在没有完全安装完成前请不要连接电源至机器。

! 在清洁或者保养之前, 请拔下电源插头, 切断电源。

! 在安装或保养机器的时候请戴上工作手套。

! 未成年、身心不健全、及缺乏相关经验者需要在正常成年人看护下安全使用本产品。8岁以下或者不在成人监督下的儿童不得对机器进行清洁和保养。

! 本产品设计于成人操作, 儿童需要在监督下确保不会玩弄机器。

! 本产品设计于成人操作, 儿童不可以随意摆弄显示和控制元件。

! 请勿在无安装支撑架的情况下使用油烟机!

! 油烟机不可用于支撑表面除非特殊标出。

! 机器安装的前提是充分通风, 当厨房油烟机和油烟或其他燃料设备一起使用时。

! 本产品的管道系统不能连接任何其他用途的通风系统, 例如燃气或者油燃烧消耗后的烟气排放。

! 油烟机的下方禁止食物自行燃烧。

! 明火会导致烧着过滤网引起火灾风险, 务必避免此种情况的发生。

! 所有炒菜必须谨慎操作方式油温过热或者引起火花。油烟机的相关配件可能会因此温度过高受损。

! 请遵守当地权威机构发布的条文以安全专业的方法排放油烟。

! 油烟机内外必须定时清洁。(至少每月一次)。

! 必须按照手册中的指示保养机器。不恰当的操作或会引起火灾。

! 请勿在照明灯错误安装的情况下使用或者离开油烟机, 否则会导致漏电风险。

! 本公司不对任何不按照用户手册操作所导致的错误、损坏或者火灾负责。

! 本产品已根据欧盟有关废弃电子设备 (WEEE) 回收指令2002/96/EC进行了鉴定。正确处理废弃产品可以避免对环境和人类健康产生负面影响。



产品或外包装上该图标表示该产品不能作为家庭废弃物处理, 而应该交给回收电器或电子设备的回收站处理。正确处理废弃产品可以避免对环境和人类健康产生负面影响; 有关产品回收方面的详细讯息, 请联络当地电器回收站、家庭垃圾处理机构或您所购买该产品的商店。

处理废弃旧电气时, 请保证移除电源线和门开关以及门封, 以防儿童被反锁在内。

确保产品正确回收, 避免给环境及人身健康造成的负面影响。如需更多回收细节请致电废品收购站或您购买该产品的店铺。

产品设计、测试和制造基于:

- **安全性:** EN/IEC 60335-1; EN/IEC 60335-2-31, EN/IEC 62233.

- **性能:** EN/IEC 61591; ISO 5167-1; ISO 5167-3; ISO 5168; EN/IEC 60704-1; EN/IEC 60704-2-13; ISO 3741; EN 50564; IEC 62301.
- **电磁兼容性:** EN 55014-1; CISPR 14-1; EN 55014-2; CISPR 14-2; EN/IEC 61000-3-2; EN/IEC 61000-3-3.

改善环境影响的正确使用建议: 在烹饪开始前的几分钟里打开最小风量, 烹饪及结束后仍然保持开启状态几分钟。当大量的油烟和蒸汽出现时可以调高风量。极少数情况调到最大风量。定期更换破过滤网对保持空气清新的效率很有必要。按照手册指示使用最大排风直径可以有效提高效率, 减少噪音。

附加安装明细:

仅限使用产品提供的螺丝安装, 如果没有提供, 请采购正确的螺丝型号。请使用正确长度的螺丝, 手册中有指示。

如有疑问, 请致电咨询售后服务中心或者相关的专业人员。

警告! 不相符的螺丝安装或者没有按照手册操作的安装可能会导致触电危险。

使用

油烟机用于直排方式或者循环方式。



直排方式

依靠排气管连接到烟机的顶部以防止油烟外溢到建筑外侧。

注意! 排气管不随产品提供, 需另外采购。排气管的直径必须与连接口径相同。

水平的排气管道必须向上略微倾斜(大约10°)以便将油烟排到外部。

注意! 如果油烟机提供炭过滤网, 请移除。

用相同直径的排气管连接排气孔和油烟机(边缘连接)。

使用尺寸较小的排气管和较小的墙上排风孔会导致吸力效果不佳和噪音增加。

与此相关的问题, 我司不予负责。

- ! 使用排气管的最短长度
- ! 尽可能少的弯曲管道(最大弯角: 90°)。
- ! 避免管道横截面的剧烈变化。
- ! 使用一个内部尽可能平整的排气管。
- ! 管道必须是认证材料所做。



循环方式

从方式需要破过滤网, 可以从零售商处得到。

油烟中的油脂和异味被破过滤网除去, 然后干净的空气从烟机上方网格回到室内。

安装

灶具以上烹饪设备的支撑面和机器最低的部分之间最小的距离, 与电磁炉之间必须不少于50cm, 与燃气灶或者燃气电子混合灶之间的最小距离不小于65cm。

如果炉灶的使用手册中特别标出更大的距离, 务必按照炉灶使用手册指示操作。



连接电源

主电源必须符合位于油烟机内铭牌上的指定评级。如果设置有一插头连接到一个插座符合现行法规并定位在一个连接区域, 在安装之后, 如果它不装有一个插头(直接电源连接), 或者如果插头没有位于一个可连接的区域, 在安装后, 与按照安装说明应用两极开关, 保证了目前的Ⅲ类电源的完全断开。

警告! 在重新连接油烟机电路到主电源之前, 请检查电源线是否正确组装。
油烟机有一个特殊的电源线; 如果电源线损坏, 请向技术服务要求一个新的电源线。

悬挂安装

重量很重的产品; 油烟机的安装和搬运必须至少有两个人进行。在开始安装之前:
检查所购买的产品是选定的安装面积是否大小合适。

- 取出破过滤网(*)。如果提供了的话 (另见相关章节)。这/这些是/是要以循环方式安装的话。
- 检查 (用于运输原因) · 油烟机里没有提供其他材料 (例如螺丝包(*), 保证书(*), 等等) 拿出来保存好。
- 如果可以的话, 移开橱柜的门可以方便油烟机的安装在墙壁上。否则放一个厚的保护层在厨房的台面上以防止炉灶周围被碎片等损坏。选择用于组装的平面, 盖上保护罩将油烟机的部件和硬件装上去。
- 另外检查是否靠近油烟机的安装面积 (包括油烟机可以伸展到的面积) 的电源插座可用并且有油烟排放装置连接到外部 (仅吸入式版本)。
- 进行所有必要的砌筑工作 (例如 · 电源插座的安装和 · 或电管的通道孔)

墙壁上的插座应可延伸确保油烟机壁式/吸顶式。一个合格的技术人员必须根据壁式/吸顶式的类型验证材料的适宜性。壁式/吸顶式必须足够结实, 这取决于油烟机的重量。不要用瓷砖, 灌浆或硅胶将油烟机固定在墙上。请使用表面悬挂安装。

操作

使用大风量集中厨房蒸汽情况。建议抽油烟机在烹饪之前5分钟开启, 在烹饪过程中, 并在终止烹饪后约15分钟后关闭。



选择功能 · 触摸控制键。

T1. 准备模式 (控制面板关闭 · 功能不能使用) / **开启** (控制面板打开)

注意: 一分钟未操作 (排气和照明), 油烟机会自动调整为准备模式

T2. 开/关照明

只有部分机型 (详见上图):

重复按键选择想要的光亮度:

L1: 低亮度

L2: 中亮度

L3: 高亮度

再按关闭照明

T3. 开/关 自动操作

油烟机自动设定排气风量(功率) 1 增加如果环境条件被油烟机的感应装置感应到。

如果环境条件没有变化 · 10分钟后(如果排气风量已经达到

(功率) 1), 油烟机会关闭。

注意: 正确使用此功能 · 首先要进行“自动运行参数设置” (详见相关段落)。

注意: 在自动运行中 · 如果用户采用了其他功能调节风量功率 · 自动调节功能将自动关闭。

T4. 手动选择风量速度 (功率):

L4: 风量速度 (功率) 1

L5: 风量速度 (功率) 2

L6: 风量速度 (功率) 3

再按键关闭油烟机(关闭)。

注意: 手动选择不包括任何其他相关的风量设置功能。

T5. 开/关 强化风量速度 (功率) „POWER BOOST“ (定时)

注意: 运行5分钟后油烟机回到原来的状态。

T6*. (只有某些型号的开/关强化风量速度 (功率) „POWER BOOST x 2“ (定时)

注意: 运行5分钟后油烟机回到原来的状态。

T7. 开/关 运行模式 “空气清新”

每小时内, 前50分钟不开启, 然后10分钟按风量速度 (功率1)开启。

T8. 开/关延迟关闭风量速度 (功率) (大约30分钟)

注意: 此功能适用于可以用按键T4选择风速的型号。

T9. 过滤网清洁提示和重置过滤网污度

该按键会亮起稳定的光, 提醒进行滤网清洁。按键与指示灯闪烁时, 提醒进行碳过滤网更换。

清洁或更换后, 油烟机关闭, 然后开机, 长按此按键3秒重设过滤网污度, 如有必要, 重复操作 (例如, 当两个过滤网都需要清洁时)

碳过滤网更换提醒

碳过滤网更换提醒通常情况下不可用。可以通过以下方式激活: 在开启烟机, 关闭风量速度的情况下, 同时长按3秒按键T8和T9; 按键T9的灯会稳定亮起大约5秒, 以示激活。

重复操作则禁用此功能; 按键 T9闪烁大约5秒, 以示禁用。

自动运行参数设置

为了正确使用自动运行功能, 执行“油烟机校准”。

油烟机校准

在开启烟机, 关闭风量速度的情况下, 长按按键 T3 3秒。

风量速度 (功率) 1 开始工作和按键T3 闪烁指示油烟机校准开始, 将持续约5分钟。

注意: 中断校准, 长按 T3 5秒钟, 重复操作, 校准将被中止。

维护

注意! 在进行任何保养维护之前, 必须拔掉插头, 切断电源。

清洁

油烟机需要定期清理内外部 (至少与替换或清洁过滤网的频率相同), 使用中性质液体清洁剂浸湿软布清洁, 不要使用研磨类清洗剂。不要使用酒精!

警告: 未定期进行过滤网清洁和更换可能会引起火灾。因此, 我们建议仔细阅读手册上的指示。制造商对于不遵守上述安全建议或者维护不当所导致的马达损坏和火灾不承担任何责任。

油脂过滤网

过滤烹饪时的油粒子。油脂过滤网必须每月一次使用非刺激性的洗涤剂, 用手或者放在洗碗机 (设置成低温短时清洗) 内清洗。放在洗碗机内清洗时, 油脂过滤网会略有褪色, 但并不影响其过滤能力。向下拉弹簧卡扣可以移出油脂过滤网。

碳过滤网 (只限于循环方式)

可吸收因烹饪而引起的油烟气味。根据烹饪的类型以及油脂过滤网的使用和清洁频率, 碳过滤网会达到饱和。在任何情况下, 至少每四个月有必要更换一次, 碳过滤网不能清洗或再利用。

更换灯泡

油烟机配备LED照明技术。LED保证最优化的照明, 持续时间高达传统灯泡的10倍, 节省90%的电能。

更换事宜, 请联系技术服务。

gorenje

BY

STARCK®