

GB

# INDUCTION HOB

## I6443C



**Hisense**

**Congratulations** on the purchase of your new Induction Hob.

We recommend that you spend some time to read this Instruction / Installation Manual in order to fully understand how to install correctly and operate it.

For installation, please read the installation section.

Read all the safety instructions carefully before use and keep this Instruction / Installation Manual for future reference.

## Safety Warnings

Your safety is important to us. Please read this information before using your cooktop.

### Installation

#### Electrical Shock Hazard

- Disconnect the appliance from the mains electricity supply before carrying out any work or maintenance on it.
- Connection to a good system is essential and mandatory.
- Alterations to the domestic wiring system must only be made by a qualified electrician.
- Failure to follow this advice may result in electrical shock or death.

#### Important safety instructions

- Read these instructions carefully before installing or using this appliance.
- No combustible material or products should be placed on this appliance at any time.
- Please make this information available to the person responsible for installing the appliance as it could reduce your installation costs.
- In order to avoid a hazard, this appliance must be installed according to these instructions for installation.
- This appliance is to be properly installed and without earthed only by a suitably qualified person.
- This appliance should be connected to a circuit which incorporates an isolating switch providing full disconnection from the power supply.
- Failure to install the appliance correctly could invalidate any warranty or liability claims.

## **Operation and maintenance**

### **Electrical Shock Hazard**

- Do not cook on a broken or cracked cooktop. If the cooktop surface should break or crack, switch the appliance off immediately at the mains power supply (wall switch) and contact a qualified technician.
- Switch the cooktop off at the wall before cleaning or maintenance.
- Failure to follow this advice may result in electrical shock or death.

### **Health Hazard**

- This appliance complies with electromagnetic safety standards.
- However, persons with cardiac pacemakers or other electrical implants (such as insulin pumps) must consult with their doctor or implant manufacturer before using this appliance to make sure that their implants will not be affected by the electromagnetic field.
- Failure to follow this advice may result in death.

### **Hot Surface Hazard**

- During use, accessible parts of this appliance will become hot enough to cause burns.
- Do not let your body, clothing or any item other than suitable cookware contact the Induction glass until the surface is cool.
- Beware: magnetisable metal objects worn on the body may become hot in the vicinity of the cooktop. Gold or silver jewellery will not be affected.
- Keep children away.
- Handles of saucepans may be hot to touch. Check saucepan handles do not overhang other cooking zones that are on. Keep handles out of reach of children.
- Failure to follow this advice could result in burns and scalds.

### **Cut Hazard**

- The razor-sharp blade of a cooktop scraper is exposed when the safety cover is retracted. Use with extreme care and always store safely and out of reach of children.
- Failure to use caution could result in injury or cuts.

### **Important safety instructions**

- Never leave the appliance unattended when in use. Boilover causes smoking and greasy spillovers that may ignite.
- Never use your appliance as a work or storage surface.
- Never leave any objects or utensils on the appliance.
- Do not place or leave any magnetisable objects (e.g. credit cards, memory cards) or electronic devices (e.g. computers, MP3 players)

near the appliance, as they may be affected by its electromagnetic field.

- Never use your appliance for warming or heating the room.
- After use, always turn off the cooking zones and the cooktop as described in this manual (i.e. by using the touch controls). Do not rely on the pan detection feature to turn off the cooking zones when you remove the pans.
- Do not allow children to play with the appliance or sit, stand, or climb on it.
- Do not store items of interest to children in cabinets above the appliance.
- Children climbing on the cooktop could be seriously injured.
- Do not leave children alone or unattended in the area where the appliance is in use.
- Children or persons with a disability which limits their ability to use the appliance should have a responsible and competent person to instruct them in its use. The instructor should be satisfied that they can use the appliance without danger to themselves or their surroundings.
- Do not repair or replace any part of the appliance unless specifically recommended in the manual. All other servicing should be done by a qualified technician.
- Do not use a steam cleaner to clean your cooktop.
- Do not place or drop heavy objects on your cooktop.
- Do not stand on your cooktop.
- Do not use pans with jagged edges or drag pans across the Induction glass surface as this can scratch the glass.
- Do not use scourers or any other harsh abrasive cleaning agents to clean your cooktop, as these can scratch the Induction glass.
- If the power supply cable is damaged, it must only be replaced by a qualified technician.
- This appliance is intended to be used in household and similar applications such as: -staff kitchen areas in shops, offices and other working environments; -farm houses; -by clients in hotels, motels and other residential type environments ; -bed and breakfast type environments.
- This appliance can be used by children aged from 8 years and above and persons with reduced physical, sensory or mental capabilities or lack of experience and knowledge if they have been given supervision or instruction concerning use of the appliance in a safe way and understand the hazards involved. Children shall not play with the appliance. Cleaning and user maintenance shall not be made by children without supervision.

- **WARNING:** Unattended cooking on a hob with fat or oil can be dangerous and may result in fire. NEVER try to extinguish a fire with water, but switch off the appliance and then cover flame e.g. with a lid or a fire blanket.
- Metallic objects such as knives, forks, spoons and lids should not be placed on the hob surface since they can get hot.
- After use, switch off the hob element by its control and do not rely on the pan detector.
- The appliance is not intended to be operated by means of an external timer or separate remote-control system.
- **CAUTION:** The cooking process has to be supervised. A short term cooking process has to be supervised continuously.
- **WARNING:** In order to prevent tipping of the appliance, this stabilizing means must be installed. Refer to the instructions for installation.
- **WARNING:** Use only hob guards designed by the manufacturer of the cooking appliance or indicated by the manufacturer of the appliance in the instruction for use as suitable or hob guards incorporated in the appliance. The use of inappropriate guards can cause accidents.

# Product Overview

## Top View

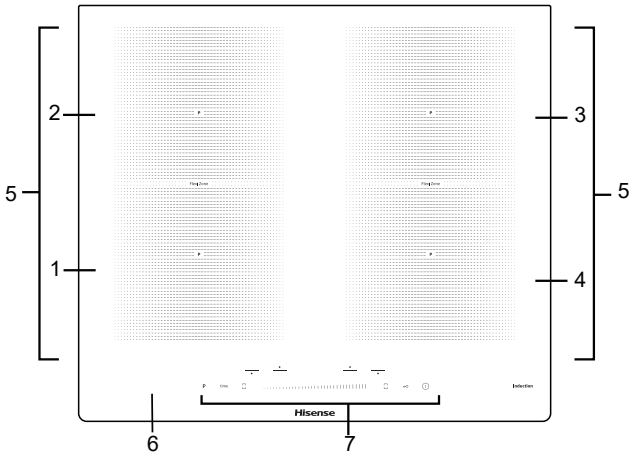

- 1. Heating zone: 190x190 mm  
1800W / 2100W (P)
- 2. Heating zone: 190x190 mm  
1800W / 2100W (P)
- 3. Heating zone: 190x190 mm  
1800W / 2100W (P)
- 4. Heating zone: 190x190 mm  
1800W / 2100W (P)
- 5. Flex area, 3000W / 3400W (P)
- 6. Glass plate
- 7. Control panel

## Control Panel

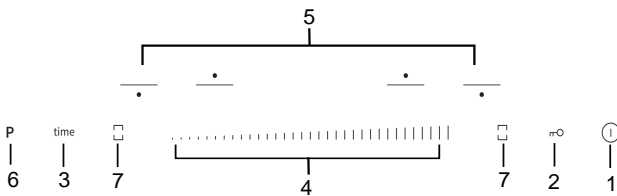

- 1. ON/OFF control
- 2. Child lock control
- 3. Timer control
- 4. Power / Timer regulating controls
- 5. Heating zone selection
- 6. Boost control
- 7. Activation key and disabling the flexible region

## A Word on Induction Cooking

Induction cooking is a safe, advanced, efficient, and economical cooking technology. It works by electromagnetic vibrations generating heat directly in the pan, rather than indirectly through heating the glass surface. The glass becomes hot only because the pan eventually warms it up.

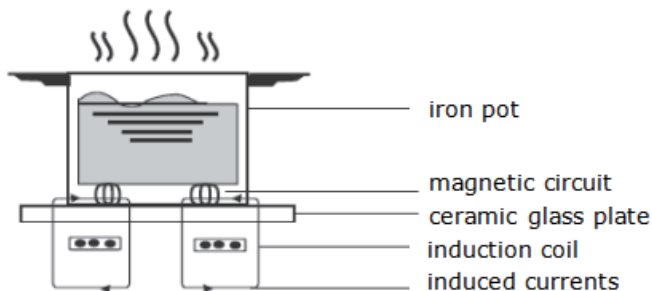

## Before using your New Hob

- Read this guide, taking special note of the 'Safety Warnings' section.
- Remove any protective film that may still be on your Induction hob.

## Using the Touch Controls

- The controls respond to touch, so you don't need to apply any pressure.
- Use the ball of your finger, not its tip.
- You will hear a beep each time a touch is registered.
- Make sure the controls are always clean, dry, and that there is no object (e.g. a utensil or a cloth) covering them. Even a thin film of water may make the controls difficult to operate.

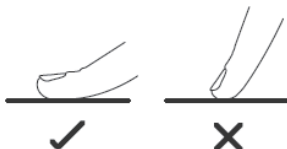

## Choosing the right Cookware



- Only use cookware with a base suitable for induction cooking. Look for the induction symbol on the packaging or on the bottom of the pan.
  - You can check whether your cookware is suitable by carrying out a magnet test. Move a magnet towards the base of the pan. If it is attracted, the pan is suitable for induction.
- If you do not have a magnet:
1. Put some water in the pan you want to check.
  2. If  does not flash in the display and the water is heating, the pan is suitable.
- Cookware made from the following materials is not suitable: pure stainless steel, aluminium or copper without a magnetic base, glass, wood, porcelain, ceramic, and earthenware.

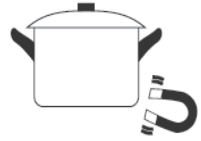

Do not use cookware with jagged edges or a curved base.



Make sure that the base of your pan is smooth, sits flat against the glass, and is the same size as the cooking zone. Use pans whose diameter is as large as the graphic of the zone selected. Using a pot a slightly wider energy will be used at its maximum efficiency. If you use smaller pot efficiency could be less than expected. Always centre your pan on the cooking zone.

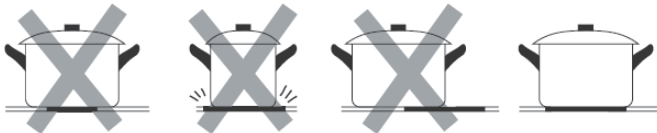

Always lift pans off the Induction hob – do not slide, or they may scratch the glass.

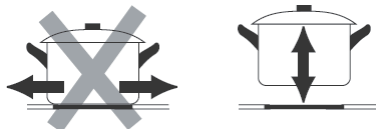

## Pan dimensions

The cooking zones are up to a limit, automatically adapted to the diameter of the pan. However the bottom of this pan must have a minimum of diameter according to the corresponding cooking zone. To obtain the best efficiency of your hob, please place the pan in the centre of the cooking zone.



## The base diameter of induction cookware

Cooking zone	Minimum (mm)
190mm	160
Flex zone	200

## Using your Hob

### SETTING THE MAXIMUM TOTAL APPLIANCE POWER

The induction hob is equipped with Power management system. The maximum power of the hob is limited to 7200 W.

This setting can be reduced to 2300 W, 2800 W, 3000 W or 3700 W. When the total power limit is activated, the power of each cooking zone can only be increased until the total power reaches the limit.

1. To activate Power management, connect the power, then touch the ON/OFF control button the appliance and simultaneously press the left front and the right front heating zone control button for 3 seconds.
2. When the power management is activated, the current maximum power is shown on the timer LED display - for example, if the timer display shows 7.2, it means that the maximum power limit for the unit is 7200W.
3. To set the new maximum power level:
  - a. Press the timer icon - the timer display starts flashing with the current maximum power limit
  - b. Press the right front heating zone control button to select the new desired power limit. By pressing the right front heating zone button different maximum power values will be shown – values will be circling by the button pressing

2.3 > 2.8 > 3.0 > 3.7 > 7.2 > 2.3 > ...

(2300 W > 2800 W > 3000 W > 3700 W > 7200 W > 2300 W > ...)



When you have selected the new maximum power value, save the new setting by pressing the timer button. The message "Pn" appears on the display of the timer for a few seconds. The new maximum power value is set.

If a lower maximum total power is set, it is not possible to set a high power level on all cooking zones simultaneously.

Remark: If want to reset the maximum total appliance power, need to disconnect the appliance from the power and reconnect it again.  
If do not adjust the total power limit within five minutes, need to disconnect the appliance from the power and reconnect it again.

## To start cooking

1. After the power management choosing operation done, all displays show "—" or "--", then you can choose any heating zone to cook directly.
2. Place a suitable pan on the cooking zone that you wish to use.
  - Make sure the bottom of the pan and the surface of the cooking zone are clean and dry.
3. Touching heating zone selection control ,and a indicator next to the key will flash "0"
4. Adjust cooking power with control the slider

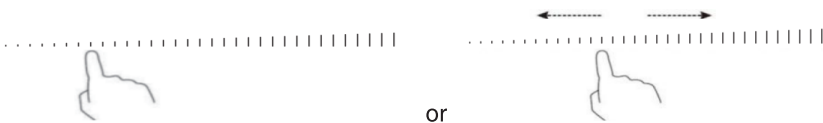
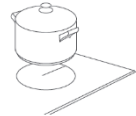

- If you do not adjust the cooking power after one minute, the unit will stop automatically. You will need to repeat to touch the ON/OFF control button and repeat the procedure from step 2.
- You can change the cooking power at any time during cooking.
- Slide from right to left ,the power decreases from one step each time until the step 0.
- Slide from left to right, the power increases by one step each time until step 9.

## If the display flashes alternately with the heat setting

This means that:

- you have not placed a pan on the correct cooking zone or,
- the pot you use is unsuitable for induction cooking or,
- the pan is too small or not properly centered on the cooking zone.

No heating takes place unless there is a suitable pan on the cooking zone.

The screen automatically turns off after 1 minute if no suitable pan is placed on it.

## When you have finished cooking

1. Touching the heating zone selection control that you want to switch off.



2. To turn off the cooking zone: Turn the cooking zone off by scrolling down to "0". Make sure the display shows "0"

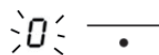

3. Turn off the hob completely by pressing the ON / OFF switch.

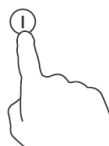

### Beware of hot surfaces residual heat indicator

"H" will show which cooking zone is hot to touch. It will disappear when the surface has cooled down to a safe temperature. It can also be used as an energy saving function if you want to heat further pans, use the hotplate that is still hot.

## Locking the Controls

- You can lock the controls to prevent unintended use (for example children accidentally turning the cooking zones on).
- When the controls are locked, all the controls except the ON/OFF control are disabled.

### To lock the controls

Touch the child lock control  . The timer indicator will show “Lo”

### To unlock the controls

1. Make sure the hob is turned on.
2. Touch and hold the child lock control  for a while.
3. You can now start using your hob.



When the hob is in the lock mode, all the controls are disabled except the ON/OFF, you can always turn the induction hob off with the ON/OFF control in an emergency, but you shall unlock the hob first in the next operation

## Using the Timer

You can use the timer in two different ways:

- You can set it to turn one cooking zone off after the set time is up;
- You can set it to turn more than one cooking zone off;



### Setting the timer to switch off the one required heating area

1. Select the cooking zone by touching the zone you want to set the timer, (for example, 25 minutes)
2. Set the power level to 6 by slider

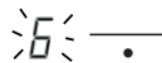
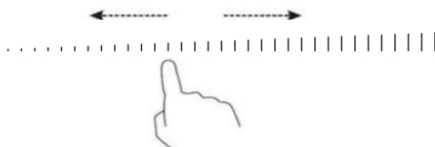

3. To touch the timer control , will show default “00” and single digit “0” flashing, you can slide the slider from 0 to 5, then touch the timer control again, ten digit “0” flashing, slide to “2”, to finish the clock, after will show “25”.

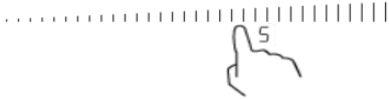

**Advice** : Press the timer control first time to increase or decrease the setting by 1 minute intervals.

Press the timer control second time to decrease or increase the setting by 10 minutes interval.

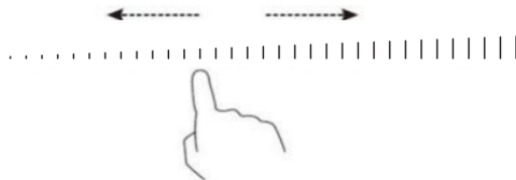

4. When the timer is set, the countdown will begin immediately. The remaining time is displayed and the timer indicator will blink for 5 seconds.

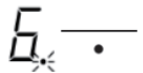

**Note** : A red point next to the power indicator light indicating the selected area.

5. Select the source for which you want to cancel the timer, slide the slider to cancel the timer and "00" will be displayed.

When the timer period is finished, the cooking zone switches off automatically and indicates "H".



Other cooking zones continue to function normally if they were lit independently.

## Setting a timer to turn more than one cooking zone off

If you use this function for more than one heating zone, the timer indicator will show the shortest time (for example, zone 2- Installation time - 3 minutes, zone 3- Installation time - 6 minutes, timer indicator will show "3". )

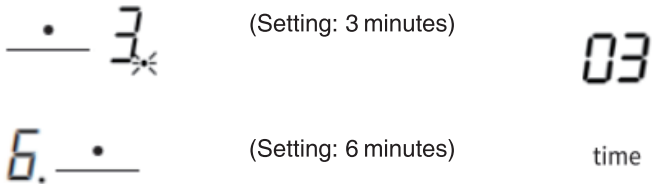

**Note** : The red dot next to power level indicator will illuminate indicating that zone is selected.

If you want to check the set time for another heating zone, press the button to select another heating zone. The timer will show set time for this zone.

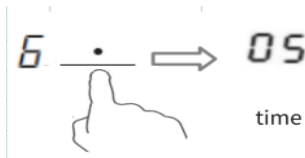

When the cooking timer expires, the corresponding heating zone will be switch off automatically and show "H".

**Note:** If you want to change the time setting of the timer when it start, you should repeat the procedure from step 1.



## Using the Boost

"Boost" is the function that heats an area with greater power for a period of 5 minutes (maximum). So you can get more powerful and faster cooking.

## Use of Boost for faster cooking.

1. Touch the cooking zone that you want to use the Boost function.  
The indicator next to the button blinks.

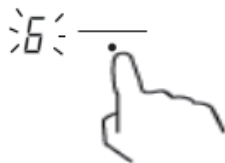

2. Touch the Boost button, the cooking zone will start to operate in Boost mode (maximum power). The power display shows "P" to indicate that the zone is in boost mode.

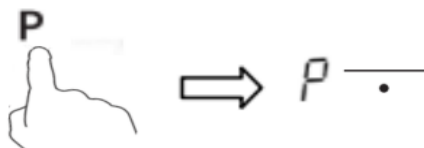

3. The Boost power will last for 5 minutes. Then the power will return to the power 9.



If you wish to cancel the Boost during 5 minutes, first select the cooking zone and then press the Boost button. Power returns to the power level set before Boost activation.

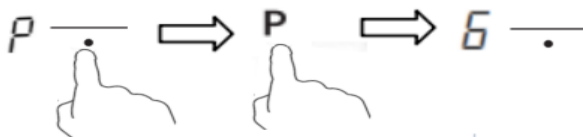



## Restrictions when using the Boost (P)

All of the cooktop has a maximum power. When the Boost function is enabled and not to exceed the maximum power, the electronic control automatically reduces the level of cooking another heating zone.

## FLEXI ZONE

### Burner Combination

This function  is used if one burner is not enough to heat the dishes properly (for example, large dishes for fish or meat). To enable the "FLEXI / Combination cooking zone" function, press the corresponding button  on the display in the display.

If necessary, it can be used as a single burner or as two independent burners. In this case, there are two inductors operating independently of each other. During operation of the free heating zone, only that area on which the cookware is installed is activated.

If more than one burner is needed to place the cookware, install it starting from the top or bottom edge of the free heating zone.

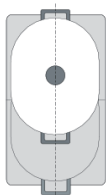

## Use of two independent burners

The front and rear burners (in each case with two inductors) can be used independently of each other. Set the required degree of heating for each burner separately. Use only one pan/pan for each burner.

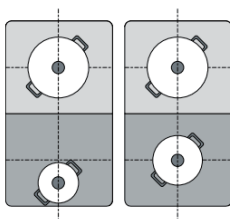

## Recommendations

Place cookware on cooking surfaces with more than one free heating zone so that only one of the free heating zones is covered. Otherwise, the hobs do not activate correctly, which will negatively affect the cooking result.

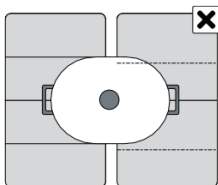



## Great area

1. To enable flexible area as one large area, just press the button below cons.
2. To adjust the power level by sliding the slider from 0 to 9.
3. Press again the following against key to use the flexible area as two independent areas. The cooking zones will operate independently of each other.



## Over-Temperature Protection

A temperature sensor equipped can monitor the temperature inside the Induction hob. When an excessive temperature is monitored, the Induction hob will stop operation automatically.

## Detection of Small Articles

When an unsuitable size or non-magnetic pan (e.g. aluminium), or some other small item (e.g. knife, fork, key) has been left on the hob, the hob automatically go on to standby in 1 minute. The fan will keep cooking down the induction hob for a further 1 minute.

## Auto Shutdown Protection

Auto shut down is a safety protection function for your hob. It shut down automatically if ever you forget to turn off your cooking. The default working times for various power levels are shown in the below table:

Power level	1	2	3	4	5	6	7	8	9
Default working timer (hour)	8	8	8	4	4	4	2	2	2



People with a heart pace maker should consult with their doctor before using this unit.

## Liquid Overflow Protection

When around 140ml liquid overflow on the control panel and keeps on more than 3 buttons for about 10 seconds, the induction hob will stop working automatically.

## Cooking Guidelines



Take care when frying as the oil and fat heat up very quickly, particularly if you're using high power. At extremely high temperature oil and fat will ignite spontaneously and this presents a serious fire risk.

### Cooking Tips

- When food comes to the boil, reduce the temperature setting.
- Using a lid will reduce cooking times and save energy by retaining the heat.
- Minimise the amount of liquid or fat to reduce cooking times.
- Start cooking on a high setting and reduce the setting when the food has heated through.

### Simmering, cooking rice

- Simmering occurs below boiling point, at around 85°C, when bubbles are just rising occasionally to the surface of the cooking liquid. It is the key to delicious soups and tender stews because the flavours develop without overcooking the food. You should also cook egg-based and flourthickened sauces below boiling point.
- Some tasks, including cooking rice by the absorption method, may require a setting higher than the lowest setting to ensure the food is cooked properly in the time recommended.

### Searing steak

To cook juicy flavoursome steaks:

1. Stand the meat at room temperature for about 20 minutes before cooking.
2. Heat up a heavy-based frying pan.
3. Brush both sides of the steak with oil. Drizzle a small amount of oil into the hot pan and then lower the meat onto the hot pan.
4. Turn the steak only once during cooking. The exact cooking time will depend on the thickness of the steak and how cooked you want it. Times may vary from about 2 – 8 minutes per side. Press the steak to gauge how cooked it is – the firmer it feels the more 'well done' it will be.
5. Leave the steak to rest on a warm plate for a few minutes to allow it to relax and become tender before serving.

## For stir-frying

1. Choose an induction compatible flat-based wok or a large frying pan.
2. Have all the ingredients and equipment ready. Stir-frying should be quick. If cooking large quantities, cook the food in several smaller batches.
3. Preheat the pan briefly and add two tablespoons of oil.
4. Cook any meat first, put it aside and keep warm.
5. Stir-fry the vegetables. When they are hot but still crisp, turn the cooking zone to a lower setting, return the meat to the pan and add your sauce.
6. Stir the ingredients gently to make sure they are heated through.
7. Serve immediately.

## Heat Settings

The settings below are guidelines only. The exact setting will depend on several factors, including your cookware and the amount you are cooking. Experiment with the induction hob to find the settings that best suit you.

Heat setting	Suitability
1 - 2	<ul style="list-style-type: none"><li>• delicate warming for small amounts of food</li><li>• melting chocolate, butter, and foods that burn quickly</li><li>• gentle simmering</li><li>• slow warming</li></ul>
3 - 4	<ul style="list-style-type: none"><li>• reheating</li><li>• rapid simmering</li><li>• cooking rice</li></ul>
5 - 6	<ul style="list-style-type: none"><li>• pancakes</li></ul>
7 - 8	<ul style="list-style-type: none"><li>• sautéing</li><li>• cooking pasta</li></ul>
9	<ul style="list-style-type: none"><li>• stir-frying</li><li>• searing</li><li>• bringing soup to the boil</li><li>• boiling water</li></ul>

## Care and Cleaning

What?	How?	Important!
Everyday soiling on glass (fingerprints, marks, stains left by food or non-sugary spillovers on the glass)	<ol style="list-style-type: none"> <li>1. Switch the power to the cooktop off.</li> <li>2. Apply a cooktop cleaner while the glass is still warm (but not hot!)</li> <li>3. Rinse and wipe dry with a clean cloth or paper towel.</li> <li>4. Switch the power to the cooktop back on.</li> </ol>	<ul style="list-style-type: none"> <li>• When the power to the cooktop is switched off, there will be no 'hot surface' indication but the cooking zone may still be hot! Take extreme care.</li> <li>• Heavy-duty scourers, some nylon scourers and harsh/abrasive cleaning agents may scratch the glass. Always read the label to check if your cleaner or scourer is suitable.</li> <li>• Never leave cleaning residue on the cooktop: the glass may become stained.</li> </ul>
Boilovers, melts, and hot sugary spills on the glass	<p>Remove these immediately with a fish slice, palette knife or razor blade scraper suitable for Induction glass cooktops, but beware of hot cooking zone surfaces:</p> <ol style="list-style-type: none"> <li>1. Switch the power to the cooktop off at the wall.</li> <li>2. Hold the blade or utensil at a 30° angle and scrape the soiling or spill to a cool area of the cooktop.</li> <li>3. Clean the soiling or spill up with a dish cloth or paper towel.</li> <li>4. Follow steps 2 to 4 for 'Everyday soiling on glass' above.</li> </ol>	<ul style="list-style-type: none"> <li>• Remove stains left by melts and sugary food or spillovers as soon as possible. If left to cool on the glass, they may be difficult to remove or even permanently damage the glass surface.</li> <li>• Cut hazard: when the safety cover is retracted, the blade in a scraper is razor-sharp. Use with extreme care and always store safely and out of reach of children.</li> </ul>
Spillovers on the touch controls	<ol style="list-style-type: none"> <li>1. Switch the power to the cooktop off.</li> <li>2. Soak up the spill</li> <li>3. Wipe the touch control area with a clean damp sponge or cloth.</li> <li>4. Wipe the area completely dry with a paper towel.</li> <li>5. Switch the power to the cooktop back on.</li> </ol>	<ul style="list-style-type: none"> <li>• The cooktop may beep and turn itself off, and the touch controls may not function while there is liquid on them. Make sure you wipe the touch control area dry before turning the cooktop back on.</li> </ul>

## Hints and Tips

Problem	Possible causes	What to do
The induction hob cannot be turned on.	No power.	Make sure the induction hob is connected to the power supply and that it is switched on. Check whether there is a power outage in your home or area. If you've checked everything and the problem persists, call a qualified technician.
The touch controls are unresponsive.	The controls are locked.	Unlock the controls. See section 'Using your induction cooktop' for instructions.
The touch controls are difficult to operate.	There may be a slight film of water over the controls or you may be using the tip of your finger when touching the controls.	Make sure the touch control area is dry and use the ball of your finger when touching the controls.
The glass is being scratched.	Rough-edged cookware.  Unsuitable, abrasive scourer or cleaning products being used.	Use cookware with flat and smooth bases. See 'Choosing the right cookware'.  See 'Care and cleaning'.
Some pans make crackling or clicking noises.	This may be caused by the construction of your cookware (layers of different metals vibrating differently).	This is normal for cookware and does not indicate a fault.
The induction hob makes a low humming noise when used on a high heat setting.	This is caused by the technology of induction cooking.	This is normal, but the noise should quieten down or disappear completely when you decrease the heat setting.
Fan noise coming from the induction hob.	A cooling fan built into your induction hob has come on to prevent the electronics from overheating. It may continue to run even after you've turned the induction hob off.	This is normal and needs no action. Do not switch the power to the induction hob off at the wall while the fan is running.
Pans do not become hot and  appears in the display.	The induction hob cannot detect the pan because it is not suitable for induction cooking.  The induction hob cannot detect the pan because it is too small for the cooking zone or not properly centred on it.	Use cookware suitable for induction cooking. See section 'Choosing the right cookware'.  Centre the pan and make sure that its base matches the size of the cooking zone.

The induction hob or a cooking zone has turned itself off unexpectedly, a tone sounds and an error code is displayed (typically alternating with one or two digits in the cooking timer display).	Technical fault.	Please note down the error letters and numbers, switch the power to the induction hob off at the wall, and contact a qualified technician.
---	------------------	--

Never attempt to disassemble the unit by yourself.

## Failure Display and Inspection

If an abnormality comes up, the induction hob will enter the protective state automatically and display corresponding protective codes:

<b>Error code</b>	<b>Description</b>
<u>U</u>	No pot or No appropriate pot, please put the appropriate pot;
F3/F4	Temperature sensor of the induction coil failure
F9/FA	Temperature sensor of the IGBT failure.
E1/E2	Abnormal supply voltage. High voltage (Above $270\pm 10V$ ) Low voltage (Below $180\pm 10V$ )
E3	There is a protection that when dry burning or high temperature on the surface of the heating stove.
E5	The fan don't work or is blocked, then can not dissipate heat.
d0	NTC failure NTC sensor fail which can't detect the temperature variable. NTC is thermistor, which is placed in the middle of the coil of induction hob, like a wire in the shape of a mushroom head, used to sense temperature.
O1	The induction coil without screw or the the screw is loose.
E0	An error occurred in the communication between the control board and the main board

The above are the judgment and inspection of common failures.

Please do not disassemble the unit by yourself to avoid any dangers and damages to the induction hob.

## Technical Specification

Cooking Hob	I6443C
Cooking Zones	4 Zones
Supply Voltage	220-240V~, 50/60Hz
Installed Electric Power	7200W
Product Size LxWxH (mm)	590X520X56
Building-in Dimensions AxB (mm)	560X490

Weight and Dimensions are approximate. Because we continually strive to improve our products we may change specifications and designs without prior notice.

## Installation

### Selection of installation equipment

Cut out the work surface according to the sizes shown in the drawing.

For the purpose of installation and use, a minimum of 5 cm space shall be preserved around the hole.

Be sure the thickness of the work surface is at least 30mm. Please select heat-resistant work surface material to avoid larger deformation caused by the heat radiation from the hotplate. As shown below:

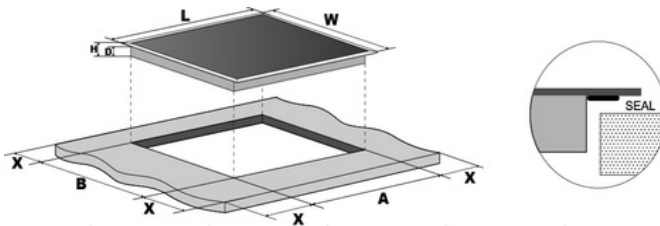

Model	L(mm)	W(mm)	H(mm)	D(mm)	A(mm)	B(mm)	X(mm)
I6443C	590	520	56	52	560	490	50

Under any circumstances, make sure the Induction cooker hob is well ventilated and the air inlet and outlet are not blocked. Ensure the Induction cooker hob is in good work state. As shown below



*Note:* The safety distance between the hotplate and the cupboard above the hotplate should be at least 500mm.

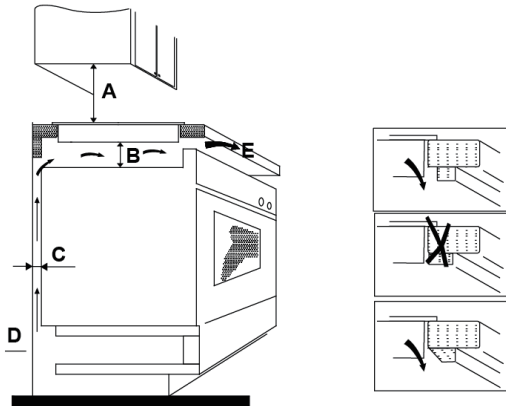

A(mm)	B(mm)	C(mm)	D	E
min. 500	min. 20	min. 20	Air intake	Air exit 5 mm

## Before you install the hob, make sure that

- the work surface is square and level, and no structural members interfere with space requirements
- the work surface is made of a heat-resistant material
- if the hob is installed above an oven, the oven has a built-in cooling fan
- the installation will comply with all clearance requirements and applicable standards and regulations
- a suitable isolating switch providing full disconnection from the mains power supply is incorporated in the permanent wiring, mounted and positioned to comply with the local wiring rules and regulations.
- The isolating switch must be of an approved type and provide a 3 mm air gap contact separation in all poles (or in all active [phase] conductors if the local wiring rules allow for this variation of the requirements)
- the isolating switch will be easily accessible to the customer with the hob installed
- you consult local building authorities and by-laws if in doubt regarding installation
- you use heat-resistant and easy-to-clean finishes (such as ceramic tiles) for the wall surfaces surrounding the hob.



## When you have installed the hob, make sure that

- the power supply cable is not accessible through cupboard doors or drawers
- there is adequate flow of fresh air from outside the cabinetry to the base of the hob
- if the hob is installed above a drawer or cupboard space, a thermal protection barrier is installed below the base of the hob
- the isolating switch is easily accessible by the customer

## Before locating the fixing brackets

The unit should be placed on a stable, smooth surface (use the packaging). Do not apply force onto the controls protruding from the hob.

## Adjusting the bracket position

1. Fix the hob on the work surface by screw 4 brackets on the bottom of hob (see picture) after installation.

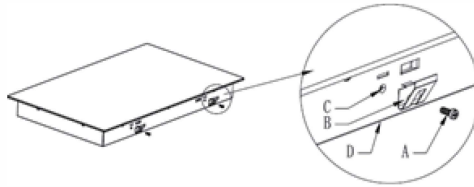

2. Fix the hob on the work surface by screw 4 brackets on the bottom of hob (see picture) after installation.

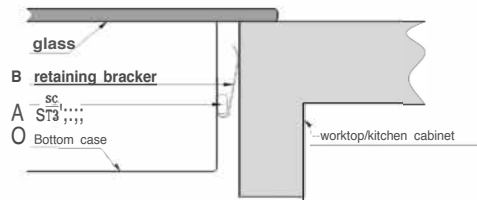

## Cautions

1. The induction hotplate must be installed by qualified personnel or technicians. We have professionals at your service. Please never conduct the operation by yourself.
2. The hob will not be installed directly above a dishwasher, fridge, freezer, washing machine or clothes dryer, as the humidity may damage the hob electronics
3. The induction hotplate shall be installed such that better heat radiation can be ensured to enhance its reliability.
4. The wall and induced heating zone above the table surface shall withstand heat.
5. To avoid any damage, the sandwich layer and adhesive must be resistant to heat.

# Flush-mount installation into the worktop

Appliances without faceted edges or decorative frames, are suitable for flush mounting.

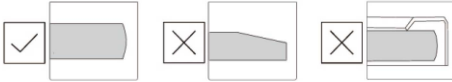

## Installing the appliance

The appliance may only be installed into a temperature- and water-resistant countertop, such as a countertop made of (natural) stone (marble, granite), or solid wood (the edges along the cut-out have to be sealed). When installing into a countertop made of ceramics, wood, or glass, a wooden sub-frame should be used. The frame is not supplied with the appliance. The appliance may only be installed into a countertop made of other materials after you have consulted the countertop manufacturer and obtained his express approval. Internal dimension of the basic unit should be at least equal to the internal cutout for the appliance. This will allow simple removal of the appliance from the countertop. Attach sealing tape along the perimeter of the bottom of the glass panel.

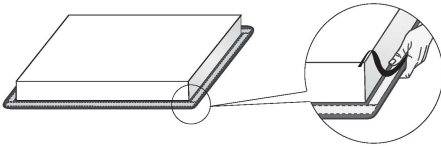

First, feed the power cord through the cutout. Place the appliance over the centre of the cutout. Connect the appliance to the power mains (see instructions for connecting the appliance). Before sealing the appliance, test its operation. Seal the slot between the appliance and the countertop using a silicone sealant. The silicone sealant used to seal the appliance has to be temperature-resistant (to at least 160 °C). Smooth out the silicone sealant using a suitable tool. Observe the instructions for use of the selected silicone sealant. Do not switch on the appliance until the silicone sealant has dried completely.

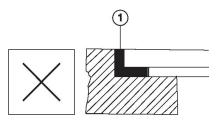
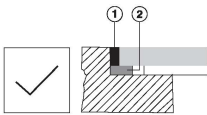

1. Silicone sealant
2. Sealing tape

## WARNING!

Pay particular attention to built-in dimensions with (natural) stone countertops. When choosing the silicone sealant, observe the countertop material and consult the countertop manufacturer. Use of inappropriate silicone sealants can result in permanent discolouration of some parts.

## Removing the built-in appliance

Disconnect the appliance from the power mains. Use a suitable tool to remove the silicone gasket from the perimeter. Remove the appliance by pushing it upwards from the bottom side.

## WARNING!

Do not attempt to remove the appliance from the upper side of countertop.

## WARNING!

The service department shall only be responsible for repair and servicing of the cooking hob. Consult your specialized kitchen equipment dealer regarding the re-installation (of the flush-mount) cooking hob.

### Stone countertop

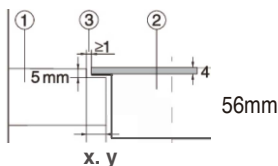

1. Countertop
2. Appliance
3. Slot

Given the margin of error (tolerance) for the glass ceramic plate of the appliance, and the cutout in the countertop, the slot is adjustable (min.2 mm).

### Ceramic, wooden, or glass countertop

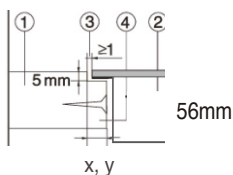

1. Countertop
2. Appliance
3. Slot
4. Wooden frame, thickness 16 mm

Given the margin of error (tolerance) for the glass ceramic plate of the appliance, and the cut-out in the countertop, the slot is adjustable (min. 2mm). Install the wooden frame 5.5mm below the upper edge of the countertop (see figure).

Observe the radii of glass edges (R10, R2) when making the cut-out.

GLASS

CUT-OUT



## Connecting the hob to the mains power supply



This hob must be connected to the mains power supply only by a suitably qualified person.

Before connecting the hob to the mains power supply, check that:

1. the domestic wiring system is suitable for the power drawn by the hob.
2. the voltage corresponds to the value given in the rating plate
3. the power supply cable sections can withstand the load specified on the rating plate.

To connect the hob to the mains power supply, do not use adapters, reducers, or branching devices, as they can cause overheating and fire. The power supply cable must not touch any hot parts and must be positioned so that its temperature will not exceed 75°C at any point.



Check with an electrician whether the domestic wiring system is suitable without alterations. Any alterations must only be made by a qualified electrician.

This hob is a Class II appliance. Class II appliances have two layers of insulation. The double insulation removes a need for an earth connection.

The Class II appliance symbol is shown as below, you can find it on rating label



The power supply should be connected in compliance with the relevant standard, or a single-pole circuit breaker – The method of connection is shown below.

**Use Power line H07RN-F, 4 x 1,5 mm<sup>2</sup>**

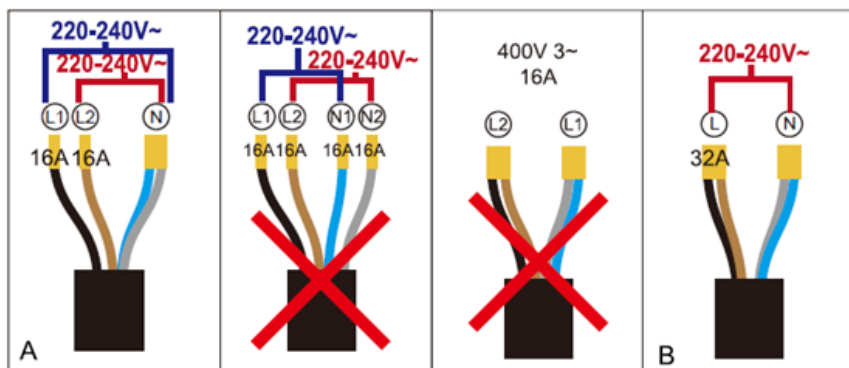

Black  
Brown  
Blue and Grey

Black and Brown  
Blue and Grey

**Two-phase connection** – If your electric mains have 2 line conductors and 1 neutral conductor, connect the appliance as shown in Diagram A.

**Single-phase connection** – Connect the appliance as shown in Diagram B.

**Hisense**