

Hisense

life reimagined

EN

GB

IE

INSTRUCTIONS FOR USE

BUILT-IN OVEN

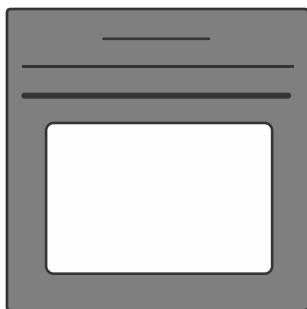

We thank you for your trust and the purchase of our appliance.

This detailed instruction manual is supplied to make the use of this product easier. The instructions should allow you to learn about your new appliance as quickly as possible.

Make sure you have received an undamaged appliance. If you do find transport damage, please contact the seller from which you purchased the appliance, or the regional warehouse from which it was supplied. The telephone number can be found on the invoice or on the delivery note.

Instructions for installation and connection are supplied on a separate sheet.

The following symbols are used throughout the manual and they have the following meanings:



INFORMATION!

Information, advice, tip, or recommendation



WARNING!

Warning – general danger



It is important that you carefully read the instructions.

Contents

1. Safety precautions	4
2. Other important safety warnings	5
3. Appliance description	7
3.1 Appliance equipment	7
3.2 Control panel	8
4. Before first use	9
4.1 Switching on for the first time	9
5. Using the oven – selecting the baking settings	11
5.1 Professional baking mode	12
5.2 Time functions	14
5.3 Baking by steps	15
5.4 Automatic cooking mode	16
5.5 Automatic programs	17
5.6 Additional functions	19
6. Starting the cooking process	20
6.1 Additional browning – au gratin	20
6.2 Cooking with addition of steam	20
7. End of cooking by touching	21
8. General settings	22
8.1 Locking keys	24
9. ConnectLife and connectivity (Wi-Fi)	25
9.1 Connecting the appliance to a mobile device	25
9.2 Wi-Fi module settings	25
10. General tips and advice for baking	28
10.1 Cooking table	29
10.2 Cooking with a temperature probe	33
11. Cleaning and maintenance	36
11.1 Cleaning the oven (Steam Clean)	36
11.2 Removing wire and fixed pull-out (extendible) guides	37
11.3 Removing and replacing the oven door and glass panes	37
11.4 Replacing the bulb	38
12. Troubleshooting	40
12.1 Troubleshooting table	40
12.2 Label – appliance information	41
13. Compliance information	41
14. Environment protection	41
15. Cooking test	43

1. Safety precautions

IMPORTANT SAFETY PRECAUTIONS – CAREFULLY READ THE INSTRUCTIONS AND SAVE THEM FOR FUTURE REFERENCE.

Appliance must be connected to fixed wiring which has incorporated means of disconnection. Fixed wiring must be made in accordance with the wiring rules.

Means for disconnection must be incorporated in the fixed wiring in accordance with the wiring rules.

The appliance must not be installed behind a decorative door in order to avoid overheating.

If the supply cord is damaged, it must be replaced by the manufacturer, its service agent or similarly qualified persons in order to avoid a hazard (only for appliances supplied with connection cord).

This appliance can be used by children aged 8 years and above, and by persons with reduced physical, sensory or mental capabilities or lack of experience and knowledge, if they have been given supervision or instruction concerning the use of the appliance in a safe way, and if they understand the hazards involved. Children shall not play with the appliance. Cleaning and user maintenance shall not be done by children without supervision.

WARNING: Accessible parts may become hot during use. Young children should be kept away.

WARNING: The appliance and some of its accessible parts may become very hot during use. Care should be taken to avoid touching heating elements. Children less than 8 years of age shall be kept away unless continuously supervised.

The appliance is not intended to be controlled by external timers or separate remote control system.

Only use the temperature probe recommended for use in this oven.

Do not use harsh abrasive cleaners or sharp metal scrapers to clean the oven door glass/ the glass of hinged lids of the hob (as appropriate), since they can scratch the surface, which may result in shattering of the glass.

Do not use steam cleaners or high-pressure cleaners to clean the appliance as this may result in an electric shock.

WARNING: Before replacing the light bulb, make sure the appliance has been disconnected from the mains power, in order to prevent the hazard of an electric shock.

Never pour water directly on the bottom of the oven cavity. Temperature differences could result in damage to the enamel coating.

2. Other important safety warnings

The appliance is intended for household use. Do not use it for any other purpose, such as room heating, drying of pets or other animals, paper, fabrics, herbs etc. As this may lead to injury or fire hazard.

Appliance must be connected to fixed wiring which has incorporated means of disconnection. Fixed wiring must be made in accordance with the wiring rules.

We recommend that (due to appliance weight) at least two persons carry and install the appliance.

Do not lift the appliance by holding it by the door handle.

Oven door hinges may be damaged when under excessive load. Do not stand or sit on the open oven door, and do not lean against it. Also, do not place any heavy objects onto the oven door.

If the power cords of other appliances located in the vicinity of the oven become entangled in the oven door, they may get damaged, which may cause a short circuit. Therefore, make sure that the power cords of other appliances are at a safe distance.

Make sure the vents are never covered or obstructed in any other way.

Do not line the oven walls with aluminium foil and do not place baking trays or other containers on the bottom of the oven. This would reduce air circulation in the oven, obstruct and slow down the baking process and destroy the enamel coating.

We recommend you avoid opening the oven door during baking, as this increases power consumption and increases condensate accumulation.

At the end of the baking process, and during baking, be careful when opening the oven door, as there is danger of scalding.

To prevent limescale accumulation, leave the oven door open after baking or using the oven, to allow the oven cavity to cool down to room temperature.

Clean the oven when it has completely cooled down.

Eventual mismatches in colour shades between different appliances or components within a single design line may occur due to various factors, such as different angles under which the appliances are observed, different coloured backgrounds, materials, and room illumination.

Do not use the appliance if it is damaged. Unplug the appliance from the power mains and call an authorized service centre.

The oven can be safely used with or without baking pan guides.

Do not store items in the oven, which could cause danger when the oven is switched on.



WARNING!

Carefully read the instructions for use before connecting the appliance. Repair or any warranty claim resulting from incorrect connection or use of the appliance shall not be covered by the warranty.

3. Appliance description



WARNING!

Appliance functions and equipment depend on the model.

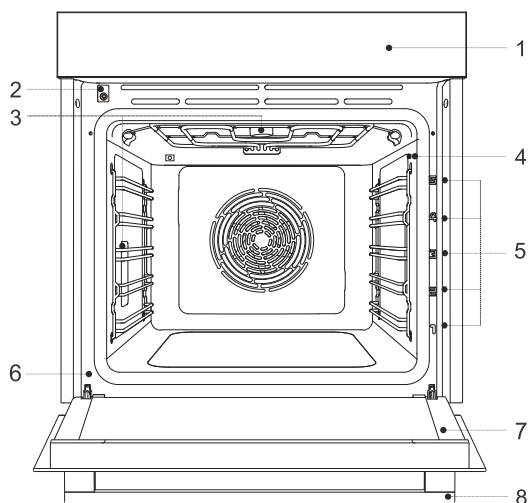

1. Control panel
2. Door switch
3. Lighting
4. Temperature probe socket
5. Guides – rack levels
6. Label
7. Oven door
8. Door handle

3.1 Appliance equipment

Oven door switch

The switch switches off the operation of the heaters and the ventilation in the oven room when the oven door is opened during operation.

Guides

Wire guides – always insert the wire rack and baking tray into the guide.

Fixed pull-out guides – place the equipment on the guide. On the same guide, you can place the rack together with the drip pan.

NOTE: Equipment insertion guides are counted from the bottom up.

Oven equipment and accessories

1. **Wire rack** – used for grilling/broiling or as support for a pan, baking tray or baking dish.

NOTE: When inserting the wire rack into the guide, always make sure its elevated part is at the back and on the top side.

There is a safety latch on the wire rack. Therefore, the wire rack has to be lifted slightly at the front when pulling it out from the oven.

2. **Shallow baking tray** – used for flatbreads and small cakes. It can also be used as a drip tray.

NOTE: A shallow baking tray may become deformed when heated in the oven. When it cools down, it returns to its original state. The deformation does not affect its functionality.

3. **Mesh tray Airfry** – (baking tray with holes) used for cooking with systems that feature steam injection and for air frying. The holes allow for better air flow around the food and contribute to greater crispness. When cooking food with a higher liquid content (water, fat), insert a shallow or deep universal baking tray one rack lower.

4. **Deep all-purpose baking tray** – used for baking vegetables and moist pastries. It can also be used as a drip tray.

NOTE: Never insert the deep all-purpose (or universal) baking tray into the first guide when baking.



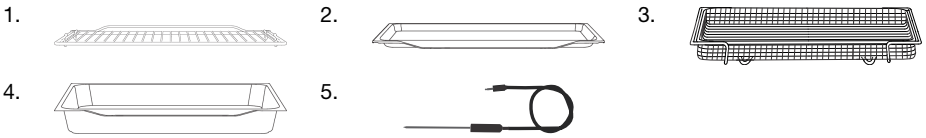



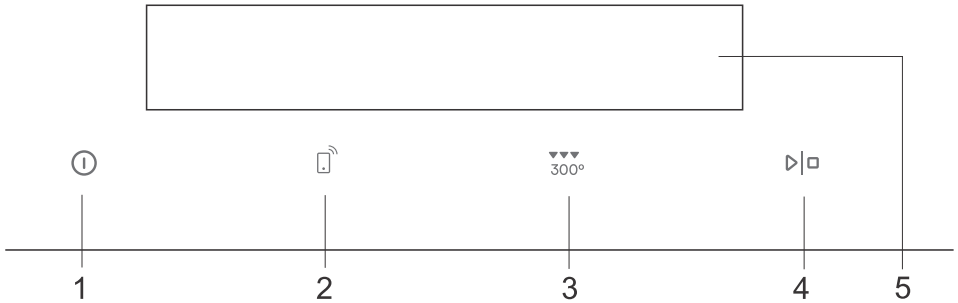

5. Temperature probe for meat - (BAKESENSOR)



3.2 Control panel



Key	Use
1	Switching the oven on and off
2	Connection setup (Wi-Fi)
3	Additional browning – au gratin
4	Starting and stopping Confirming a setting
5	Display of current settings in the oven. Illuminated part of the line - displays the currently selected field from A to E. Arrow - displays the selected basic setting (pro bake), (auto bake), (extra bake).

Shortcut key:			
	 4 s		
Briefly touch the key – to confirm the setting.	Press and hold the key (4 sec.) – for additional settings.	Rotate the button – to switch between settings and select settings.	Press the button – to confirm your selection.
			
First step	Intermediate step	Waiting / Implementation	Optional step
 INFORMATION! For better key responsiveness, touch them with a large area of your fingertip. Each time you press a key, this will be acknowledged by an acoustic signal (when this function is available).			

4. Before first use





1.	Remove oven accessories and any packaging (cardboard, polystyrene foam) from the oven.
2.	Wipe the oven accessories and interior with a damp cloth. Do not use abrasive or aggressive cloths or cleaners.
3.	Turn on the oven (see chap. 4.1 <i>Switching on for the first time</i>)
4.	Preheat the oven to 250 °C for approximately one hour using the top and bottom heater system (see chapter Professional baking mode).
NOTE: During heating, the characteristic "new smell" is released, so ventilate the room thoroughly during this time.	

4.1 Switching on for the first time

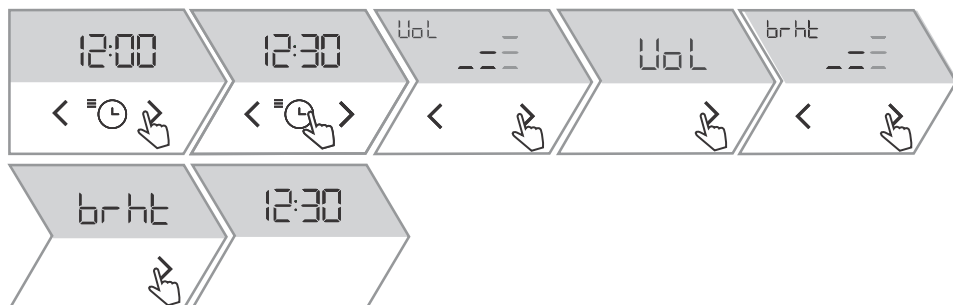
After connecting your appliance or after an extended power outage, 12:00 will flash on the display.

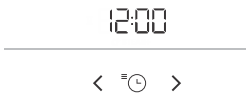
First select and confirm the basic settings below (exact time, beep volume and display illumination).



1.		With the key < or > set the exact time of day. Confirm your selection with  .
2.		The display will show Vol . With the key < or > increase or decrease the volume of beeps.
3.		When you touch > the display will show brht . With the key < or > increase or decrease the intensity of the display illumination.
4.		To exit the basic settings, touch > .

5. Using the oven – selecting the baking settings

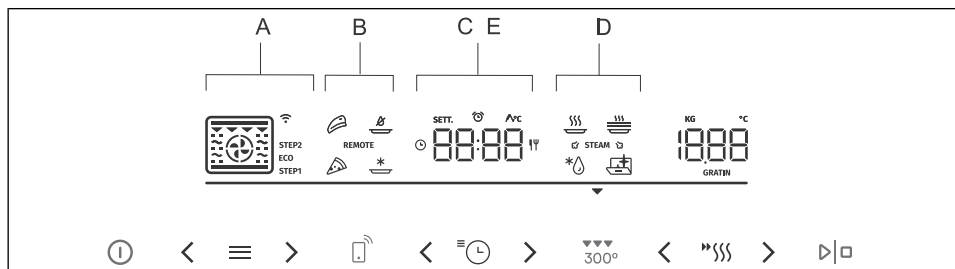

Key	Use
<	Left selection key
≡	Baking selection key. By touching the key, you can select:
Pr □	A Professional mode Pro – allows you to set the baking parameters (baking system, temperature, quick preheating, and baking time) at your discretion.
Auto	B Automatic mode Auto – special preset programmes which you can also change.
Pr □	C Automatic programmes ProG (Pr01 to Pr22)
Other	D Dodatne funkcije Othr
SEtt	E General settings SEtt
>	Right selection key
⌚	Key for setting time functions and general settings
»»»	Key for setting the quick preheat function and gratin function

NOTE: The display only illuminates the keys that can be used to set and confirm the selected setting.

Symbol	Meaning
□	Baking systems
WiFi	WiFi connection
REMOTE	Turning on the oven's remote control
STEP1	Baking by steps (STEP1, STEP2)
⌚	Time function – baking time
⌚	Time function – delayed end
⌚	Minute minder
AvC	Temperature probe for meat
☁ STEAM ☁	STEAM function to add steam during baking.
»»»	Fast preheat
GRATIN	GRATIN function for extra top crust at the end of baking.

NOTE: Some symbols on the display appear as slightly illuminated (the function is in standby mode). If you press the key to select a symbol and confirm it, the symbol's intensity will increase. This is when the function is active.

5.1 Professional baking mode

This function allows setting the baking parameters – baking system, temperature, fast preheating, and baking time – freely, at the user's discretion.

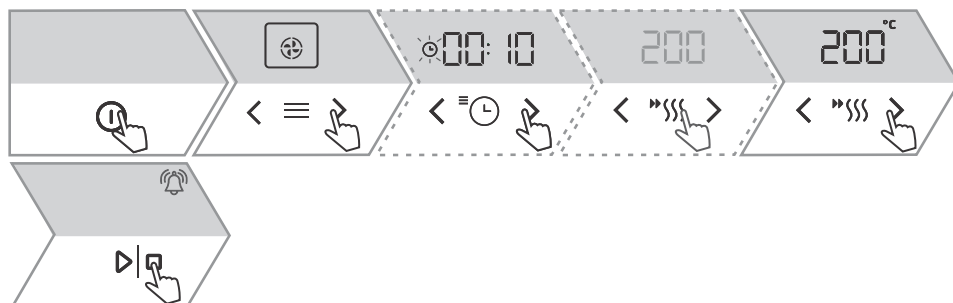

1.	Turn on the oven. For a few seconds, the display will show Pro , and then the oven settings that have been overridden are displayed.
2.	With the key < or > set the baking system (see table Selection of baking systems) and temperature.
3.	Use quick preheating to bring the oven to the desired temperature as quickly as possible. When you touch »»»» , the symbol lights up. When the set temperature is reached, an acoustic signal sounds. The display will show door . Open the door and insert the dish. The programme automatically resumes baking with the selected settings.
4.	Additionally, you can set: <ul style="list-style-type: none"> - time functions (see chapter 5.2 <i>Time functions</i>) - baking by steps (see chapter 5.3 <i>Baking by steps</i>) - gratin function (see chapter 6.1 <i>Additional browning – au gratin</i>)
5.	To start cooking, touch ▷ ◻ .

Choosing the baking system













Symbol	Use
 ☑ STEAM ☑	HOT AIR¹⁾ Hot air allows for better air circulation around the dish. In this way, it dries its surface more and creates a thicker crust. For roasting meat, baking cakes and vegetables and for drying food at one or more levels at the same time. The addition of steam roasts the food surface more and creates greater crispness.
 ☑ STEAM ☑	TOP AND BOTTOM HEATER¹⁾ Use this system for conventional baking on a single rack, making soufflés, and baking at low temperatures (slow cooking). Steam injection results in better browning and a crunchier crust.
	PIZZA SYSTEM This system is optimal for baking homemade pizza and pastry with higher water content. Use it to bake on a single rack, when you want the food to be done faster and to be crunchy.



Table continued from last page

Symbol	Use
 STEAM	INTENSIVE BAKING ¹⁾ This cooking method gives the food a crispy crust, without added fat. It is a healthy version of "fast food" with a lower calorie content. Suitable for small cuts of meat, fish, vegetables and pre-cooked frozen products (fries, chicken medallions). The addition of steam cooks the surface better and creates a crunchy crust.
	GRILL WITH HOT AIR Hot air allows better flow of hot air around the food. This will dry out the surface. In combination with the grill heater/broiler, this will also result in a more intensive colour. For faster baking of meat and vegetables.
	TURBO BAKE For dishes where even crispiness from all sides is desirable. The system is also suitable as the first step in the step baking mode, as it allows quick browning of the surface in the first stage and slow baking in the second stage. The meat will be juicy with a nicely browned crust.
	LARGE GRILL For baking large quantities of flat foods (toasted bread, canapees, sausages for grilling, steaks, fish, skewers, etc.), for cooking au gratin and for achieving a nice crispy crust. The heaters mounted on the top of the oven cavity heat the entire surface evenly. Maximum permitted temperature is 240 °C.
	GENTLE BAKING For gentle and controlled slow cooking of delicate food (soft cuts of meat) and baking pastry with a crunchy bottom.
	TOP AND BOTTOM HEATER WITH FAN For even baking of food on a single rack, and for making soufflés.
	LARGE GRILL WITH FAN For roasting poultry and larger cuts of meat under a broiler.
	LARGE GRILL AND BOTTOM HEATER For faster baking on a single rack and for crisply browning the top of your pastry.
	GRILL WITH BOTTOM HEATER AND FAN For optimum baking of yeast-leavened dough, all types of bread, and for preservation.
 ECO	ECO (SLOW COOKING) ²⁾ For gentle, slow and even cooking of meat, fish and pastries on one level. This way of cooking retains a higher proportion of water in the meat, which leaves it juicier and softer, while the pastry becomes evenly browned/baked. It is used for temperatures ranging between 140 °C and 220 °C.
NOTE: For all systems, it is possible to use the gratin function (see chapter 6.1 <i>Additional browning – au gratin</i>).	

¹⁾ The systems also allow for steam injection during baking (see chapter 6.2 *Cooking with addition of steam*).

²⁾ This function is used to determine the energy efficiency class according to EN 60350-1.

5.2 Time functions

Symbol	Description	Use
	Baking time	In this mode, you can specify the duration of operation for the oven.
	Minute minder	The minute minder operates independently of the oven operation. After the set time has expired, the appliance does not turn on or off automatically.
	Delayed end	Use this mode when you want the food in the oven to start cooking with a time delay. Enter the duration and desired end time of cooking. The appliance starts automatically and ends its operation at the desired time.

Setting the baking time



1. With the key < or > set the desired cooking time. The display will show ☰ .
2. To start cooking, touch ▷|◻ .

Setting the minute minder



1. When you touch ☰ , the display will show ⌚ . With the key < or > set the duration of the minute minder. Confirm the setting by touching ☰ .

The maximum possible setting is 24 hours.



NOTE: If the appliance is switched off, the minute minder will still be active.

Setting delayed end



1. First set the baking time. With the key < or > set the desired cooking time. The display will show ☰ .
Example: cooking time 2 hours

Table continued from last page

2.	By double-tapping  the display will show  .
3.	With the key < or > set the time at which you want the dish to be ready. The desired end time is shown on the display. <i>Example: cooking ends at 18:00</i>
4.	To start cooking, touch  . The oven goes into partial standby while waiting to be switched on (the display goes dark). The selected settings are automatically switched on and off at the selected time. <i>Example: cooking starts at 16:00, cooking ends at 18:00</i>
Cooking end time and the clock will alternate on the display unit. After the set time has expired, the oven stops working automatically. The display will show End. A short beep will be emitted.	



INFORMATION!

The selected time function can be reset to 00:00 by simultaneously touching < and > .



WARNING!





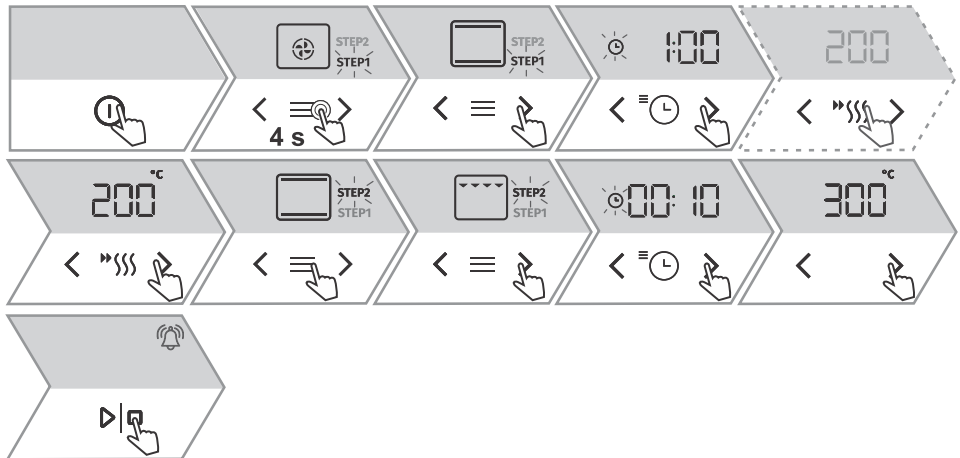

This function is not suitable for food that requires quick preheating.

Perishable food should not be kept in the oven for a long time. Before using this mode, check whether the clock on the appliance is accurately set.

5.3 Baking by steps

This function allows cooking in two steps or stages (two consecutive cooking steps are combined in a single cooking process).





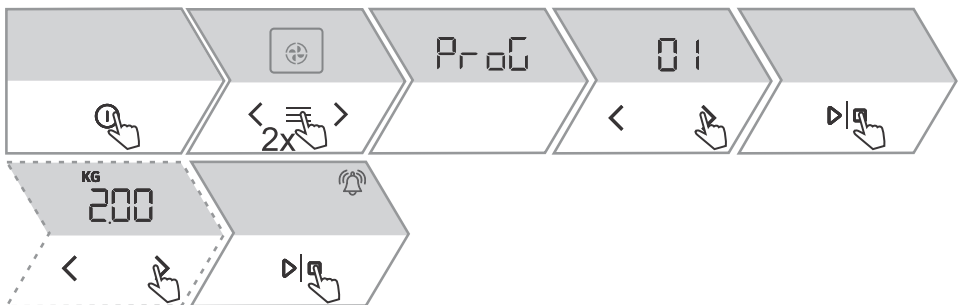

1.	1. STEP 1 Turn on the oven. The display shows the default oven setting.
2.	After a long tap (4 seconds) on  , the display will show STEP1 (the first step of preparing a dish). Set the baking system, cooking time and temperature. You can also choose fast preheating.
3.	2. STEP 2 By touching again on  , the display will show STEP2 (the second step of preparing a dish; the first step has already been set).
4.	Set the baking system, cooking time and temperature. You can also change both steps before starting cooking. By touching  , you can go between the two steps.
5.	To start cooking, touch   . The oven first starts working with the settings for the first step.
6.	Cooking by steps can be cancelled by pressing the  key for four seconds.

5.4 Automatic cooking mode

In this mode, you can choose between special operating systems.



1.	Turn on the oven. The display shows the default oven setting.
2.	Touch  . For a few seconds, the display will show Auto , and then automatic systems will be displayed. By touching  or  , first select the system (see table below). Preset values are displayed. You can change the temperature and duration of cooking.
3.	To start cooking, touch   .
4.	Some dishes also include the quick preheating function. The sign will be fully illuminated. When the set temperature is reached, an acoustic signal will sound. The display will show door . Open the door and insert the dish. The programme automatically resumes baking with the selected settings.





Symbol	Use
	BAKING FROZEN FOOD This method allows baking frozen food in a shorter period of time without pre-heating. Optimum for pre-baked frozen products (bakery products, croissants, lasagne, French fries, chicken nuggets), meat and vegetables.





Table continued from last page

Symbol	Use
	PIZZA SYSTEM This system is optimal for baking homemade pizza and pastry with higher water content. Use it to bake on a single rack, when you want the food to be done faster and to be crunchy.
	MEAT SYSTEM For optimal meat preparation. Before baking sear the meat on all sides in a pan of hot oil. This method of preparation will preserve its juiciness. It is suitable for meat cuts such as roast beef, fillet of beef, back cuts, etc.
	AIR FRY This cooking method gives the food a crispy crust, without added fat. It is a healthy version of "fast food" with a lower calorie content. Suitable for small cuts of meat, fish, vegetables and pre-cooked frozen products (fries, chicken medallions).

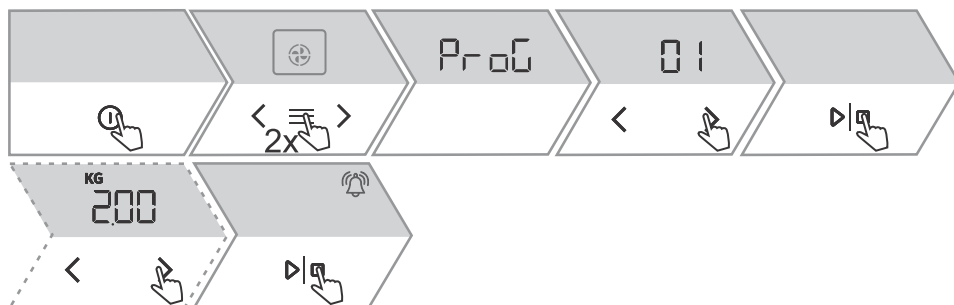
5.5 Automatic programs

In the automatic mode, you may choose between numerous automatic programmes (the appliance will recommend the optimum cooking method, temperature, and cooking duration depending on the type of food specified).



1.	Turn on the oven. The display shows the default oven setting.
2.	By double tapping  , the display will briefly show ProG , and then automatic programmes will be displayed. By touching < or > select the programme (see table below). Confirm your selection with   . Depending on the desired dish, the appliance will recommend the optimal heating mode, temperature and duration of cooking. Where possible, you can adjust the weight of the dish.
3.	To start cooking, touch   .





Designation	Program name	Equipment	Level.	Preheating	Turning
Pr01	piped cookies	shallow baking tray	3	yes	no
Pr02	cupcakes	shallow baking tray	3	yes	no
Pr03	sponge cake	baking pan/dish on wire rack	2	yes	no



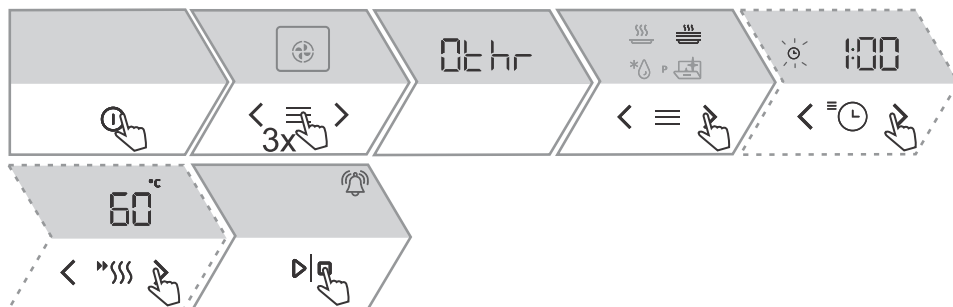

Table continued from last page

Designation	Program name	Equipment	Level.	Preheating	Turning
Pr04	yeast-leavened small pastry	shallow baking tray	2	yes	no
Pr05	puff pastry	shallow baking tray	2	yes	no
Pr06	apple pie	baking pan/dish on wire rack	2	no	no
Pr07	apple strudel	shallow baking tray	2	no	no
Pr08	chocolate soufflé	baking pan/dish on wire rack	3	yes	no
Pr09	rising and proofing	shallow baking tray	2	no	no
Pr10	bread	shallow baking tray	2	no	no
Pr11	pork roast	small baking dish on wire rack	2	no	no
Pr12	roasted beef	small baking dish on wire rack	2	no	no
Pr13	poultry – whole	wire rack with a drip tray	2	no	after 2/3 of cooking time
Pr14	poultry – smaller pieces	wire rack with a drip tray	3	no	after 2/3 of cooking time
Pr15	meat loaf	baking pan/dish on wire rack	2	no	no
Pr16	oven-baked beef steak	wire rack with a drip tray	4	no	after 2/3 of cooking time
Pr17	meat – slow cooking	small baking dish on wire rack	2	no	no
Pr18	baked/grilled fish	wire rack with a drip tray	4	no	after 2/3 of cooking time
Pr19	baked potatoes – wedges	all-purpose deep baking tray	3	no	no
Pr20	Vegetable soufflé	baking pan/dish on wire rack	2	no	no
Pr21	lasagne	baking pan/dish on wire rack	2	no	no
Pr22	homemade pizza	shallow baking tray	1	yes	no

5.6 Additional functions





1. Turn on the oven. The display shows the default oven setting.
2. By repeatedly touching , the display will briefly show **Othr**, and then additional functions will be displayed. With the key  or  select a function (see table below). Preset values are displayed. Some functions allow you to set the temperature and cooking time.
3. To start cooking, touch  .

Symbol	Use
	Defrosting Use this function to slowly defrost frozen food (cakes, pastry, bread, rolls, and deep-frozen fruit). Halfway through the defrost time, the pieces should be turned over, stirred and separated if they were frozen together.
	Reheating It is used to maintain the heat of already prepared dishes. You can set the temperature.
	Plates heating It is used if you want to preheat the plates or cups so that the food stays warm for a long time. You can set the temperature.
	Steam clean This programme makes it easier to remove stains in the oven (see chapter 11.1 <i>Cleaning the oven (Steam Clean)</i>).

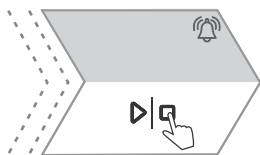
6. Starting the cooking process



Start cooking by touching  .

Until the set temperature is reached, the current and set temperature are displayed alternately. The temperature symbol flashes first, but when the desired temperature is reached, it goes out and an acoustic signal sounds.

During the cooking process, you can change the system, temperature, and timer functions.

6.1 Additional browning – au gratin



This function is used in the last phase of cooking, when we add dressing/topping to the dish or we want to crispen its surface. When using the gratin function, a crispy golden yellow crust is formed on the dish, which protects it from drying, and at the same time gives the dish a nicer appearance and better taste.

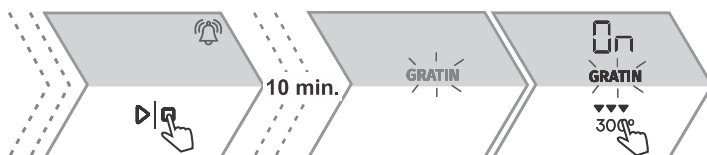

WARNING!

Control the cooking. When using the gratin function, the oven reaches high temperatures. The gratin function will be active for 15 minutes at most, then the oven switches off.



1.	While cooking, touch  . Symbol GRATIN lights up on the display, which also shows On.
2.	The function can also be switched off during operation. <ul style="list-style-type: none">- Touch , the symbol GRATIN on the display will go out and the cooking will continue according to the selected settings.- Turn off the cooking by touching .

6.2 Cooking with addition of steam

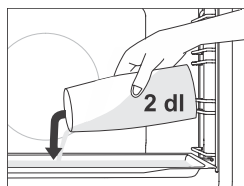

In systems **with addition of steam** , insert the shallow baking tray in the first-level guide, while the oven is still cool. Pour a maximum of 2 dl of water onto the baking sheet. Place the food to be cooked on the second level and start the system.



INFORMATION!

If you are using a deep baking tray, insert it one level higher than specified in the recommended settings table.

For optimum operation of the function, do not open the oven door and do not add water during the cooking process.

7. End of cooking by touching

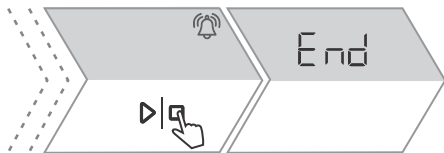

End cooking by touching . The display shows **End** and the achieved cooking time. A short beep will be emitted.



INFORMATION!

After the operation is completed, all timer settings are also stopped and deleted, except for the minute minder. Time of day (clock) will be displayed. The cooling fan will continue to operate for a while.

After the use of the oven, some water may be left in the condensate channel (underneath the door). Wipe the channel with a sponge or a cloth.

8. General settings



WARNING!

After a power outage or after the appliance is switched off, additional function settings will remain stored for no more than a few minutes. Then, all settings, except for the acoustic signal volume and display dimmer will be reset to factory defaults.

Example of time setting:

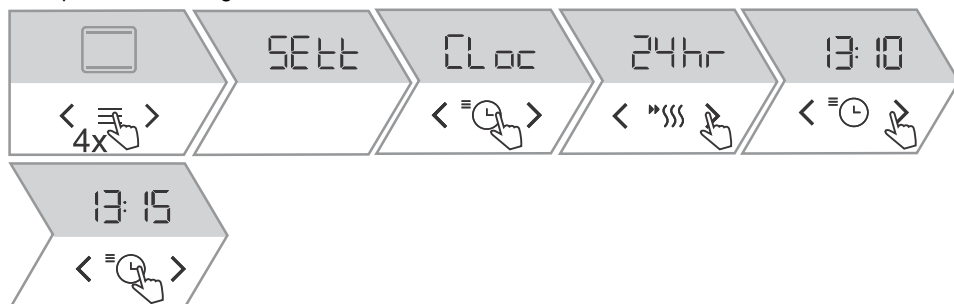





Example of adjusting the signal volume:



1.		By repeatedly touching , the display will briefly show SEtt , and then the general settings menu will be displayed. You can navigate between different settings by pressing the button. < or > .
2.		The display shows CLock . To set the clock, first touch . Select a 12h or 24h display and then set the time. Confirm the selection again by touching .
NOTE: You can edit the individual setting by pressing < or > .		
3.		Acoustic signal volume The display will show Vol . You can choose between four volume levels (zero bars – off (OFF), one, two or three bars).
4.		Display brightness Select the setting brht . You can choose between three levels of display brightness (one, two or three bars).

Table continued from last page

5.		<p>Display - night mode It is a feature that automatically reduces display brightness during night time (between 20:00 and 6:00) and turns off the clock display as well as the acoustic signals. Select the setting nGht. Select power on (On) or off (OFF).</p>
6.		<p>Hide clock It is a function that turns the clock display on or off. Select the setting hidE. Select power on (On) or off (OFF).</p>
7.		<p>Automatic quick preheating The function allows quick preheating to be automatically added to cooking systems that allow for it. Select the setting Prht. Select power on (On) or off (OFF).</p>
8.		<p>Sabbath The Sabbath function allows the food in the oven to stay warm without having to turn the oven on and off. Select the setting SAbb. Set operation duration (between 24 and 72 hours) and temperature. When you touch $\triangleright \square$, the countdown begins. The display will show SAbb. All sounds and operations are switched off except for the key ⓘ. NOTE: In case of a power outage, Sabbath mode will be deactivated and the oven will return to its initial state.</p>
9.		<p>Factory default settings This function allows the appliance to be reset to factory settings. The display will show FAct. Press $\triangleright \square$ for long enough for the line under the inscription to light up completely.</p>
<p>To exit the general settings menu, touch \equiv.</p>		

8.1 Locking keys



1. With a long tap (6 seconds) on ▷|◻ , the display will show **Loc** for locking keys. By pressing again on ▷|◻ , you disable the lock.

- If the lock is activated with no timer function engaged (only clock is displayed), then the oven will not operate.
- If the lock is activated after a timer function has been set, then the oven will operate normally; however, it will not be possible to change the settings.
- When the keys are locked, you cannot change the cooking systems or additional functions. You can only turn off the cooking.
- The keys remain locked even after the oven is switched off. To select a new system, you must deactivate the lock.

9. ConnectLife and connectivity (Wi-Fi)

The oven is fitted with a Wi-Fi  wireless connection module that allows connection between the appliance and a mobile device, e.g., a smart phone or a tablet. Connectivity allows remote monitoring of the appliance, as well as remote control of some oven functions. The **ConnectLife** app has to be installed on your mobile device, and a user account has to be registered (see chapter 9.1 *Connecting the appliance to a mobile device*).



INFORMATION!

Multiple users may be connected to the appliance simultaneously.

Prepare the SSID and password for your home network router. The appliance only supports 2.4 GHz frequency band.

Prepare the label with the QR code of the appliance unique ID (AUID) as you will need it in the appliance connection process when requested by the application.



WARNING!

The remote monitoring function via a mobile device should not be used to replace direct personal supervision of the cooking process in the oven. Always regularly check, in person, what is actually going on in the oven.

9.1 Connecting the appliance to a mobile device



The **ConnectLife** app is available in the Apple App Store and Google Play Store.

 ConnectLife



For additional help and information, please visit www.connectlife.io. For other information, functionality and support, please visit www.connectlife.io/getstarted.

9.2 Wi-Fi module settings





INFORMATION!

If this setting is not available, then your oven is not fitted with a Wi-Fi module and does not support internet connectivity.





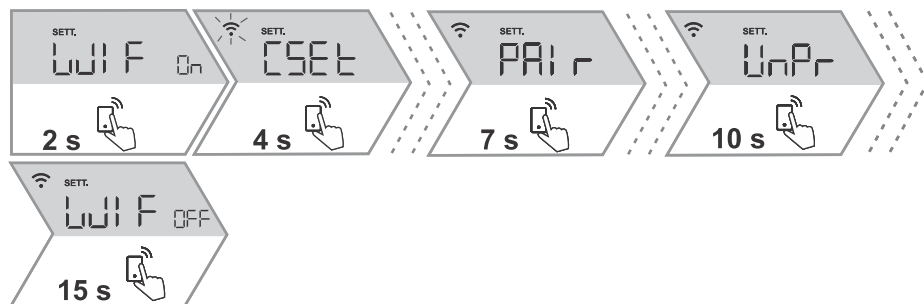

When the Wi-Fi module is enabled and connections are successfully set up and synchronized, then the oven can be controlled and operated via a mobile device and the **ConnectLife** app.

Turning the Wi-Fi module on and off

To enter the Wi-Fi module function settings, press  for the specified amount of time.

If you touch the  key erroneously, then the settings can be cancelled by long pressing (18 seconds) .



1.	<p>Turning on the Wi-Fi module:</p> <p>Long press (3 seconds)  . WIF On will appear on the display unit, indicating that the Wi-Fi module is turned on. The symbol  flashes.</p>
2.	<p>Connecting an appliance:</p> <p>Long press (6 seconds)  . CSEt On will appear on the display unit. Use this setting when connecting the appliance with the ConnectLife app. NOTE: For further settings, follow the instructions in the ConnectLife app.</p>
3.	<p>Connecting additional users:</p> <p>Long press (9 seconds)  . PAIr will appear on the display unit. Use this setting to connect additional users with the ConnectLife app. NOTE: For further settings, follow the instructions in the ConnectLife app.</p>
4.	<p>Removing all connected users:</p> <p>Long press (12 seconds)  . UnPr will appear on the display unit. Use this setting to remove all user connections from the ConnectLife app.</p>
5.	<p>Turning off the Wi-Fi module:</p> <p>Turn off the Wi-Fi connection by long pressing (15 seconds)  . WIF OFF will appear on the display unit.</p>

Managing the oven remote control

Touch the  key. The symbol **REMOTE** will light up on the display unit to indicate the option of remote control via the **ConnectLife** app.

**INFORMATION!**

For safety reasons, some functions are not available via remote access.

- If the oven is in standby mode and you open the oven door, the remote control option has to be enabled again.
- If oven door is opened during the baking process, the remote control option on the oven is disabled.
- Any user activity on the control unit will automatically disable the remote control option on the oven.
- Cancellation or completion of the baking program or process is the only option that remains available regardless of whether remote control is enabled or not.

**WARNING!**

Always make sure the oven is used correctly and in compliance with the instructions, especially when using remote control. Do not run the oven via remote access unless you are certain about what exactly is in the oven.

Wi-Fi status	Wi-Fi symbol on the display unit
Wi-Fi is disabled.	Wi-Fi symbol is not displayed on the display unit.
Wi-Fi is enabled, connection to the server is being established.	Wi-Fi icon is fully lit and flashes.
Wi-Fi is enabled, it is in the setup process or in the process of establishing connections.	Wi-Fi icon is fully lit and flashes.
Wi-Fi is enabled, there are no connections to the server.	Wi-Fi is constantly dimly lit.
Wi-Fi is enabled and it is successfully connected to the server.	The Wi-Fi symbol is constantly fully lit.
Remote control of the oven is not enabled.	REMOTE symbol is not lit on the display unit.
Remote control of the oven is enabled.	REMOTE sign is fully lit on the display unit.

10. General tips and advice for baking

Equipment:

- Use equipment made of heat-resistant non-reflective materials (supplied baking trays and dishes, enamel-coated cookware, tempered glass cookware). Bright-coloured materials (stainless steel or aluminium) materials reflect heat. As a result, thermal processing of food in them is less effective.
- Always insert the baking sheets and trays to the end of the guides. When baking on the wire rack, place the baking dishes or trays in the middle of the rack.
- Do not place the baking trays directly onto the oven cavity bottom.
- Do not use the all-purpose deep baking tray on the 1st guide level while the appliance is operating.
- Do not cover the oven cavity bottom or the wire rack with aluminium foil.
- Always place the baking dishes onto the wire rack.
- When cooking on several levels at the same time, insert the deep all-purpose baking tray into the lower level.
- If you are using parchment paper, make sure it is resistant to high-temperatures. Always trim it accordingly. Parchment paper prevents the food from sticking to the baking tray and makes it easier to remove the food from the baking tray.
- When baking directly on the wire rack, insert the all-purpose deep tray one level lower to serve as a drip tray.

Food preparation:

- For optimum food preparation, we recommend observing the guidelines specified in the cooking table. Choose the lower specified temperature and the shortest specified cooking time. When this time expires, check the results and then adjust the settings as necessary.
- When cooking according to recipes from older cookbooks, use the bottom and top heater system (as in conventional ovens) and set the temperature 10 °C lower than specified in the recipe.
- When cooking larger cuts of meat or pastry with higher water content, a lot of steam will be generated inside the oven, which in turn may condense on the oven door. This is a normal phenomenon which will not affect the operation of the appliance. After the cooking process, wipe the door and the door glass dry.

Efficient use of energy

- Preheat the oven only if indicated in the recipe or in the tables in this instruction manual. If you are using quick preheating, do not put food in the oven until the oven is fully heated, unless otherwise recommended. When heating an empty oven, a lot of energy is consumed, so if possible, we recommend that you prepare several dishes in a row or several dishes at the same time.
- Remove all unnecessary equipment from the oven during baking
- Unless it is absolutely necessary, do not open the oven door during baking.
- With longer cooking programs, you can switch off the oven approximately 10 minutes before the end of cooking time to make use of the accumulated heat.

10.1 Cooking table

NOTE: Dishes requiring a fully pre-heated oven are indicated with a single asterisk in the table. *
Dishes that only require a 5-minute preheating of the oven are indicated with two asterisks. **. In this case, do not use the quick preheating mode.























Dish			 °C	 min
PASTRY AND BAKERY PRODUCTS				
pastry/cakes in moulds				
sponge cake	3	 ECO	200-220	60-70
pie with filling	2		180	60-70
marble cake	2		170-180	50-60
cake with leavened dough, Gugelhupf (Bundt cake, pound cake)	2		170-180	45-55
open pie, tart	3		170-180	35-45
brownies	2		170-180	30-35
pastry on baking trays and dishes				
strudel	2		180-190	60-70
strudel, frozen	2		200-210	34-45
sponge roll	3	 + baking tray with water	170-180 *	13-18
buchteln	2		180-190	30-40
biscuits, cookies				
cupcakes	3		160 *	25-35
cupcakes, 2 levels	2, 4		155-165 *	30-40
yeast-leavened small pastry	2		180 *	17-22
yeast-leavened small pastry, 2 levels	2, 4		160 *	18-25
puff pastry	3	 ECO	200-220	30-45
puff pastry, 2 levels	2, 4		170 *	25-30
cookies/biscuits				
pipéd cookies	3		150 *	30-40
pipéd cookies, 2 levels	2, 4		150 *	30-40
pipéd cookies, 3 levels	1, 3, 5		145 *	40-50

Table continued from last page

























Dish			°C	min
cookies/biscuits	3	 ECO	160-180	40-50
biscuits, 2 levels	2, 4		150-160 *	20-25
meringue	3		80-100 *	120-150
meringue, 2 levels	2, 4		80-100 *	120-150
macarons	3		130-140 *	15-20
macarons, 2 levels	2, 4		130-140 *	15-20
bread				
rising and proofing	2		40-45	30-45
bread on a baking tray	2	 + baking tray with water	190-200	40-55
bread on a baking tray, 2 levels	2, 4		190-200 *	40-55
bread in a tin	3		190-200	30-45
bread in a tin, 2 levels	2, 4		200-210	30-45
flatbread (focaccia)	2		270	15-25
fresh bread rolls (Semmel/morning rolls)	3	 + baking tray with water	180-200	20-30
fresh bread rolls (Semmel/morning rolls), 2 levels	2, 4		200-210 *	15-20
toasted bread	5		240	4-6
open sandwiches	5		240	3-5
pizza and other dishes				
homemade pizza	1		300 *	4-10
homemade pizza, 2 rack levels	2, 4		210-220 *	25-30
frozen pizza	2		200-220	10-20
frozen pizza, 2 levels	2, 4		200-220	10-25
savoury pie, quiche	2		190-200	50-60
burek	2		180-190	40-50
MEAT				
beef and veal				

Table continued from last page





























Dish			 °C	 min
beef roast (loin, rump), 1.5 kg	2		160-170	130-160
boiled beef, 1.5 kg	2		200-210	90-120
sirloin, medium done, 1 kg	2		170-190 *	40-60
beef roast, slow cooked	2		120-140 *	250-300
beef steaks, well done, thickness 4 cm	4		220-230	25-30
burgers, thickness 3 cm	4		220-230	25-35
veal roast, 1.5 kg	2		160-170	120-150
pork				
pork roast, rump, 1.5 kg	3	 ECO	200-220	100-200
pork roast, shoulder, 1.5 kg	3		180-190	90-120
pork loin, 400 g	2		80-100 *	80-100
pork roast, slow cooked	2		100-120 *	200-230
pork ribs, slow cooked	2		120-140 *	210-240
pork chops, thickness 3 cm	4		220-230	20-25
poultry				
poultry, 1.2–2.0 kg	2		200-220	60-80
poultry with stuffing, 1.5 kg	2		170-180	70-90
poultry, breast	2		170-180	45-60
chicken thighs	3		210-220	25-40
chicken wings	4		210-220	25-40
poultry, breast, slow cooked	3		100-120 *	60-90
meat dishes				
meat loaf, 1 kg	2		170-180	60-70
grill sausages, bratwurst	4		230 **	8-15
FISH AND SEAFOOD				
whole fish, 350 g	4		230-240	12-20
fish fillet, thickness 1 cm	4		220-230	8-12
fish steak, thickness 2cm	4		220-230	10-15

Table continued from last page

Dish			°C	min
scallops	4		230 *	5-10
shrimps	4		230 *	3-10
VEGETABLES				
baked potatoes, wedges	3		210-220 *	30-40
baked potatoes, halved	3	 + baking tray with water	200-210 *	40-50
stuffed potato (jacket potato)	3		190-200	30-40
French fries, home-made	4		210-220 *	20-30
mixed vegetables, wedges	3	 + baking tray with water	190-200	30-40
stuffed vegetables	3		190-200	30-40
CONVENTIONAL PRODUCTS – FROZEN				
French fries	3		210-220	20-25
french fries, 2 levels	2, 4		190-210	30-40
chicken medallions	4		210-220 *	12-17
fish fingers	2		210-220	15-20
lasagne, 400 g	2		200-210	30-40
diced vegetables	2		190-200	20-30
croissants	3		170-180	18-23
BAKED PUDDINGS, SOUFFLÉS AND DISHES AU GRATIN				
potato moussaka	2		180-190	35-45
lasagne	2		180-190	35-45
sweet baked pudding	2		160-180	40-60
sweet soufflé	2		160-180 *	35-45
dishes au gratin	3		170-190	30-45
stuffed tortillas, enchiladas	2		180-200	20-35
grilling cheese	4		240 **	6-9
OTHER				

Table continued from last page

Dish			°C	min
preservation	2		180	30
sterilization	3		125	30
cooking in a bain-marie (double boiler)	2		150-170 *	/
reheating	3		60-95	/
plate warming	2		75	15

10.2 Cooking with a temperature probe (BAKESENSOR)

The temperature probe allows for accurate monitoring of the core temperature of the food during cooking.



WARNING!

The temperature probe should not be in direct vicinity of the heating elements.

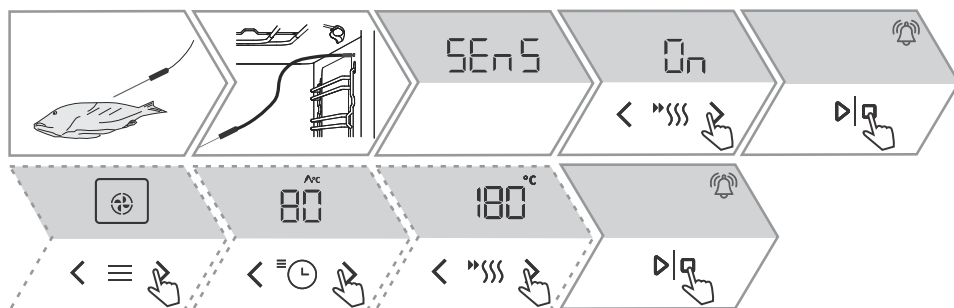

- Stick the metal end of the probe into the thickest part of the food.
- Insert the probe plug into the socket located in the upper right corner at the front of the oven (see figure).
The display will show **SEnS**. To turn on the function, touch < or > to select On. Do the same to turn off the function. On the display, select OFF. Confirm the setting by touching >|□ .
NOTE: To enter the menu **SEnS**, the current cooking must be interrupted and the temperature probe must then be plugged into the socket. By inserting the probe into the socket, the pre-set functions on the oven are deleted.
- Select the desired cooking system and temperature (up to 210 °C). The display shows the probe operating symbol and the preset temperature, which can be changed. Determine the desired final core temperature of your food (between 30 and 99 °C).
NOTE: When using the probe, setting the cooking time is not possible.
- Confirm the setting by touching >|□ .
During cooking, the set temperature and current temperature of the foodstuff are alternated on the display. If desired, you can change the cooking temperature or the desired core temperature of the foodstuff during operation.

Table continued from last page

5.	When the set core temperature is reached, the oven will stop operating. End will appear on the display unit. An acoustic signal will be heard which you may turn off by touching any key. After one minute, the acoustic signal will be switched off automatically.
----	--

Correct use of the probe, by type of food:

- poultry: stick the probe in the thickest part of the breast;
- red meat: stick the probe into a lean part that is not marbled with fat;
- smaller chunks with bone: stick them into an area along the bone;
- fish: stick the probe behind the head, towards the spine.



INFORMATION!

If you do not use the probe, remove it from the oven.



WARNING!

After use, carefully remove the probe from the food, unplug from the socket in the oven cavity, and clean it.

Recommended doneness levels for different types of meat





















Type of food	 / °C / 	medium rare	medium	medium well	well done
BEEF					
beef, roast	 / 170 / 2	48-52	53-58	59-65	68-73
beef, sirloin	 / 140 / 2	49-53	54-57	58-62	63-66
roast beef/rump steak	 / 160 / 3	49-53	54-57	58-62	63-66
burgers	 / 210 / 4	54-57	60-63	66-68	71-74
VEAL					
veal, sirloin	 / 140 / 2	49-53	54-57	58-62	63-66
veal, rump	 / 160 / 2	49-53	54-57	58-62	63-66
PORK					
roast, neck	 / 170 / 3	/	/	65-70	75-85
pork, loin	 / 140 / 2	/	/	60-69	/
meat loaf	 / 170 / 2	/	/	/	80-85
LAMB					
lamb	 / 170 / 3	60-65	66-71	72-76	77-80
MUTTON					
mutton	 / 170 / 3	60-65	66-71	72-76	77-80
GOAT MEAT					

Table continued from last page

Type of food	 / °C / 	medium rare	medium	medium well	well done
goat	 / 170 / 3	60-65	66-71	72-76	77-80
POULTRY					
poultry, whole	 / 210 / 2	/	/	/	82-90
poultry, breast	 / 170 / 2	/	/	/	62-65
FISH AND SEAFOOD					
trout	 / 210 / 4	/	/	62-65	/
tuna	 / 210 / 4	/	/	55-60	/
salmon	 / 210 / 4	/	/	52-55	/

11. Cleaning and maintenance

⚠ WARNING!

Be sure to unplug the appliance from the power supply and wait for the appliance to cool down.

Children should not clean the appliance or perform maintenance tasks without proper supervision.

- For easier cleaning, oven cavity and baking tray are coated with special enamel for a smooth and resistant surface.
- Regularly clean the appliance and use warm water and hand dishwashing liquid to remove larger impurities and limescale. Use a clean soft cloth or sponge cloth.
- Never use aggressive or abrasive cleaners and accessories (abrasive sponges and detergents, stain and rust removers, scrapers for glass ceramic plates).
- Food residue (fat, sugar, protein) can ignite during the use of the appliance. Therefore, remove larger chunks of dirt from the oven interior and accessories before each use.
- Oven equipment is dishwasher-safe.

Exterior of the appliance	Use hot soapy water and a soft cloth to remove impurities and wipe the surfaces dry.
Interior of the appliance	For stubborn dirt or grime, use conventional oven cleaners. After using such agents, wipe the appliance thoroughly with a wet cloth to remove any residual cleaning agents.
Utensils and guides	Clean with hot soapy water and a damp cloth. In case of persistent dirt, we recommend prior soaking and the use of a brush.
If the cleaning results are not satisfactory, repeat the cleaning process.	

11.1 Cleaning the oven (Steam Clean)

This program makes it easier to remove any stains from inside the oven.

The function is the most effective if used regularly, after each use.

Before running the cleaning program, remove all large visible chunks of dirt and food residues from the oven cavity.

⚠ WARNING!

Use the Steam Clean system when the oven has fully cooled down.

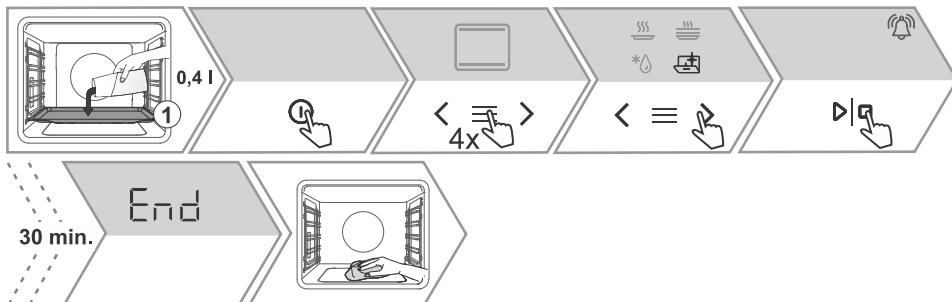

1.	Insert the shallow baking tray into the first guide level and pour 0.4 litres of hot water into it.
2.	Turn on the oven. By repeatedly touching \equiv , additional features will appear on the display. With < or > select the function  . Preset values are displayed.
3.	The program will operate for 30 minutes. When the program is complete, End will appear on the display unit.
4.	When the program is completed, carefully remove the baking tray, using oven mitts (there can still be some water on the baking tray). Wipe down the stains with damp cloth and soapsuds. Thoroughly wipe the appliance with a wet cloth to remove all cleaner residue. If the cleaning process is not successful (in case of particularly stubborn dirt), repeat it.

11.2 Removing wire and fixed pull-out (extendible) guides



INFORMATION!

When removing the guides, take care not to damage the enamel coating.

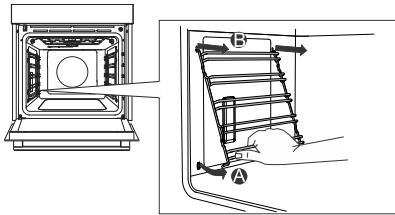

1.	Hold the guides by the bottom side and pull them towards the center of the oven cavity.
2.	Remove them from the openings at the top.

11.3 Removing and replacing the oven door and glass panes

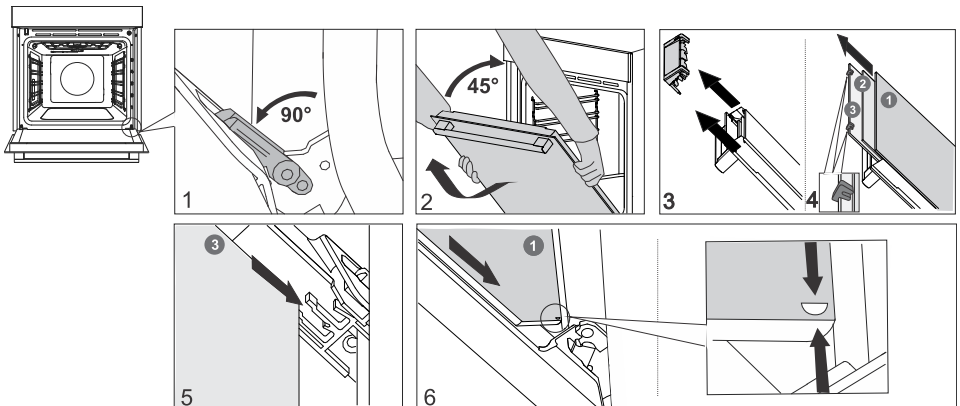

1.	First, fully open the door (as far as it will go).
----	--

Table continued from last page

2.	Oven door is attached to the hinges with special supports that also include safety levers. Rotate the safety levers towards the door by 90°. Slowly close the door to a 45° angle (relative to the position of the fully closed door); then, lift the door and pull it out. The oven door glass can be cleaned from the inside, but it has to be removed from the appliance door first. First do as described in point 2, but do not remove it.
3.	Remove the air guide. Hold it on the left- and right-hand side of the door with your hands. Remove it by slightly pulling it towards you.
4.	Hold the door glass at the upper edge and remove it. To the same for the second and third glass pane (depending on the model).
5.	To replace the glass panes, observe the reverse order.

INFORMATION!

To replace the door, follow the reverse order. If the door does not open or close properly, make sure the notches on the hinges are aligned with the hinge beds.

WARNING!

The oven door hinge can close with considerable force. Therefore, always rotate both safety levers to the support when fitting or removing the appliance door.

Soft door closing and opening

(depending on the model)

Oven door is fitted with a system that dampens the door closing force, starting at the a 75° angle. It allows simple, quiet, and gentle opening and closing of the door. A gentle push (to a 15° angle relative to the closed door position) is enough for the door to close automatically and softly.

WARNING!

If the force applied to close the door is too strong, the effect of the system is reduced or the system will be bypassed for safety.

11.4 Replacing the bulb

The light bulb is a consumable and is not covered by warranty. Before changing the bulb, remove any utensils from the oven.

Halogen lamp: G9, 230 V, 25 W

WARNING!

Only replace the light bulb when the appliance is disconnected from the power supply. Be careful not to damage the enamel. Use protection to avoid burns.

WARNING!

Appliance functions and equipment depend on the model.

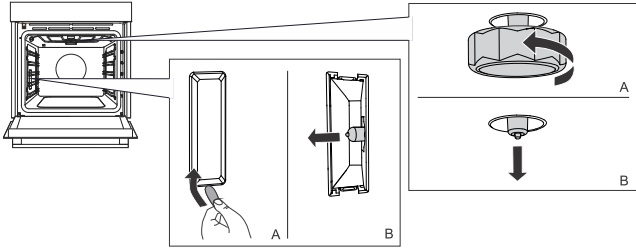

- | | |
|----|--|
| 1. | Unscrew and remove the cover (in anti-clockwise direction). Remove the halogen bulb. |
| 2. | Use a flat plastic tool to remove the cover. Remove the halogen bulb. |

12. Troubleshooting

During the warranty period, only a service center authorized by the manufacturer may carry out any repairs.

- Before making any repairs, make sure the appliance is disconnected from the power mains either by removing the fuse or by disconnecting the power plug from the wall outlet.
- Any unauthorized repairs of the appliance may result in electric shock and short circuit hazard; therefore, do not perform them. Leave such work to an expert or a service technician.
- In case of minor problems with appliance operation, check this manual to see if you can fix the problem yourself.
- If the appliance is not operating properly or at all due to inappropriate operation or handling, a visit from a service technician shall not be free of charge, even during the warranty period.
- Save the instructions for future reference and pass them on to any subsequent owners or users of the appliance.
- Following is some advice on rectifying some common problems.

12.1 Troubleshooting table

Problem/error	Cause
The main fuse in your home trips often.	Call a service technician.
The oven lighting does not work.	The process of changing the light bulb in the oven is described in the chapter Replacing the bulb.
Control unit is not responding, the screen is frozen.	Disconnect the appliance from the power mains for a few minutes (undo the fuse or switch off the main switch); then, reconnect the appliance and switch it on.
Error code ErrX is displayed. In case of a double-digit error code, the display will show ErXX.	There is an error in the electronic module operation. Disconnect the appliance from the power mains for a few minutes. If the error is still indicated, call a service technician.
The display will show SENs when the temperature probe is not connected.	Clean the socket. Try to connect and disconnect the temperature probe several times in succession.
If the problems persist despite observing the above advice, call an authorized service technician. Repair or any warranty claim resulting from incorrect connection or use of the appliance shall not be covered by the warranty. In this case, the user will cover the cost of repair.	

12.2 Label – appliance information

A rating plate with basic information about the appliance is attached to the edge of the oven. Precise information on appliance type and model can also be found on the warranty sheet.

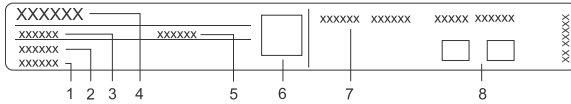

- | | |
|------------------|-------------------------------------|
| 1. Serial number | 5. ID/code |
| 2. Model | 6. QR code (depending on the model) |
| 3. Type | 7. Technical information |
| 4. Brand | 8. Compliance labels/symbols |

13. Compliance information

Radio equipment type:	Wi-Fi module
Operating frequency range:	2.412GHz - 2.472GHz
Maximum output power:	17.7dBm EIRP
Maximum antenna gain:	2.7dBi

or

Radio equipment type:	Module HLW3215-TG
Wi-Fi	
Operating frequency range:	2.4000 GHz - 2.4835 GHz
Maximum output power:	≤10dBm/MHz (EIRP) (Antenna gain<10dBi)
Maximum antenna gain:	Gain: 0dBi
Bluetooth	
Frequency range:	2.400 GHz - 2.4835 GHz
Carrier Output:	6dBm (≤10dBm)
Emission type:	F1D

Hisense declare that the radio equipment mentioned above is in compliance with Directive 2014/53/EU.

14. Environment protection



Our product packaging is made of environmentally friendly materials that can be recycled, disposed of, or destroyed without any hazard to the environment. To this end, packaging materials are labelled appropriately.

The symbol on the product or its packaging indicates that the product should not be treated as normal household waste. Take the product to an authorized collection centre for waste electric and electronic equipment processing.

Correct **disposal** of the product will help prevent any negative effects on the environment and health of people, which could occur in case of incorrect product removal. For detailed information on removal and processing of the product, please contact the relevant municipal body in charge of waste management, your waste disposal service, or the store where you bought the product.

We reserve the right to any changes and errors in the instructions for use.

15. Cooking test

EN60350-1: Only use equipment supplied by the manufacturer.

Always insert the baking tray all the way to the end position on the wire guide. Place pastry or cakes baked in moulds as shown in the image.

* Preheat the appliance to desired temperature. Do not use the rapid preheat mode.

** Preheat the appliance for 10 minutes. Do not use the rapid preheat mode.

*** Turn after 2/3 of cooking time.























BAKING						
Dish	Equipment	mould placement		 °C	 min	
biscuits/cookies – single rack	shallow baking tray		3	150	25-40	
biscuits/cookies – single rack	shallow baking tray		3	135 **	35-50	
cookies – two racks/levels	shallow baking tray		2, 4	140 **	25-40	
cookies – three racks/levels	shallow baking tray		1, 4, 5	135	45-60	
cupcakes – single rack	shallow baking tray		3	160-170 **	20-30	
cupcakes – single rack	shallow baking tray		3	155 **	20-30	
cupcakes – two racks/levels	shallow baking tray		1,5	140 **	30-45	
cupcakes – three racks/levels	shallow baking tray		1, 3, 5	140-150	30-50	
sponge cake	round metal mould, diameter 26 cm/wire rack		2	150	45-55	
sponge cake	round metal mould, diameter 26 cm/wire rack		2	160	45-55	
sponge cake – two racks/levels	2 × round metal mould, diameter 26cm/wire rack		2, 4	170 *	45-55	
apple pie	2 × round metal mould, diameter 20cm/wire rack		2	160 **	70-120	
apple pie	2 × round metal mould, diameter 20cm/wire rack		2	160	70-120	
BROILING						
toasted bread	wire rack		5	max	4-7	

Table continued from last page

BAKING						
pljeskavica (minced meat patty)	wire rack + shallow baking sheet as drip tray		5	230	25-40 ***	

Hisense
life reimagined



922702-a8

